

DOCUMENT RESUME

ED 119 143

CS 002 452

TITLE Reading Effectiveness Program: Middle, Junior and Secondary School Guide.

PUB DATE 75

NOTE 239p.; For related document see CS002451

EDRS PRICE MF-\$0.83 HC-\$12.71 Plus Postage

DESCRIPTORS \*Content Reading; Home Economics; Intermediate Grades; Mathematics Instruction; Program Evaluation; \*Reading Comprehension; \*Reading Diagnosis; Reading Instruction; \*Reading Programs; Science Instruction; Secondary Education; Social Studies; \*Study Skills

IDENTIFIERS Indiana

ABSTRACT

This guide offers suggestions for an all-school reading program focusing on four areas of instruction: a diagnostic-prescriptive instructional reading program, a content area instructional reading program, a recreational-leisure reading program, and an efficiency-study skills reading program. Techniques for diagnostic-prescriptive reading include reading interest inventories, informal reading inventories, standardized reading achievement tests, and a checklist for organizing reading instruction. Suggestions are given for teaching the developmental skills of vocabulary, comprehension, and study skills. Comprehensive sections on how to teach reading in the content areas of English, social studies, science, mathematics, and home economics are provided. A materials listing indicates level and skills use of many commercial materials. Means for evaluating the all-school reading program are suggested. (MKM)

\*\*\*\*\*  
 \* Documents acquired by ERIC include many informal unpublished \*  
 \* materials not available from other sources. ERIC makes every effort \*  
 \* to obtain the best copy available. Nevertheless, items of marginal \*  
 \* reproducibility are often encountered and this affects the quality \*  
 \* of the microfiche and hardcopy reproductions ERIC makes available \*  
 \* via the ERIC Document Reproduction Service (EDRS). EDRS is not \*  
 \* responsible for the quality of the original document. Reproductions \*  
 \* supplied by EDRS are the best that can be made from the original. \*  
 \*\*\*\*\*

U.S. DEPARTMENT OF HEALTH,  
EDUCATION & WELFARE  
NATIONAL INSTITUTE OF  
EDUCATION

THIS DOCUMENT HAS BEEN REPRO-  
DUCED EXACTLY AS RECEIVED FROM  
THE PERSON OR ORGANIZATION ORIGIN-  
ATING IT. POINTS OF VIEW OR OPINIONS  
STATED DO NOT NECESSARILY REPRE-  
SENT OFFICIAL NATIONAL INSTITUTE OF  
EDUCATION POSITION OR POLICY

ED 119143

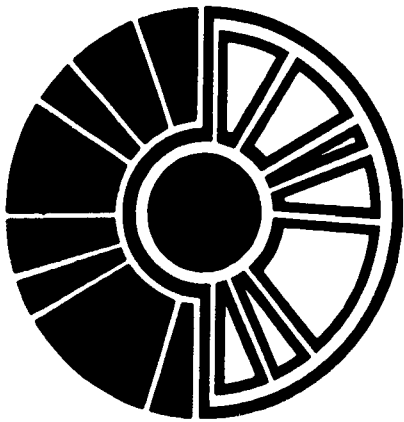

# reading effectiveness program / middle, junior & secondary school guide

Indiana Department of Public Instruction  
Harold H. Negley, Superintendent  
1975

IS 002 452

# Foreword

Millions of Americans, young and old, are handicapped socially, emotionally, educationally and economically because they cannot read well enough to function in their society. Students must be provided education at all levels that will equip them not only to compete successfully in the sophisticated employment market, but that will equip them also to understand and to live effectively with the personal and social changes of our times. The ability to read effectively, permeating as it does every other dimension of education, is clearly one challenge deserving the impetus of contemporary society. We have no option but to seek the means for making the schools more effective for all children.

We all must work cooperatively: schools, parents, colleges and universities, educational associations, community groups, in a never ending quest for a sound, success-oriented endeavor aimed at strengthening the total reading programs of local communities. Our state plan provides assistance in improving reading instruction by fostering staff development, presenting research, demonstrating ways by which skills can be taught effectively and describing innovations that may make it possible to advance reading instruction to an optimum level for everyone.

Today's pupils must learn to read with ever increasing understanding if they are to develop their talents as individuals and to function effectively in dealing with the day to day demands of our society. A total program of reading fosters the accomplishment of this endeavor. The total program of reading includes all facets of the school program which promote growth in and through reading; to improve the reading skill and the use of reading both in school and out. A total approach involves the preschool through adult population. It means involvement of the whole community, not just the schools. No one person or group of persons can accomplish this alone.

It is inexcusable that in this day, when man has achieved such giant steps in the development of his potential, when many of his accomplishments approach the miraculous, there still should be those who cannot read.

We should immediately set an unquestioned goal: Everyone must be taught to read to the best of his or her ability. This opportunity to read effectively is basic to the optimal functioning of our public educational system. Having arrived at a time which holds forth the possibility of eliminating this failure, we must, in all justice, seize the opportunity with the utmost vigor and determination. My faith in the citizenry of Indiana and professional expertise of our educators affirms my optimism in the realization of meeting this challenge with a high degree of success.

**Harold H. Negley**  
State Superintendent

# Contents

Introduction . . . . .	3
<b>Section I Developing a Middle, Junior High and Senior High School Reading Program</b>	
1. Developing a Reading Program . . . . .	7
<b>Section II Techniques for Diagnostic-Prescriptive Teaching of Reading</b>	
2. Techniques for Teaching Reading . . . . .	19
3. Determining Skill Needs . . . . .	33
4. Organizing for Instruction . . . . .	35
<b>Section III Developmental Skills</b>	
5. Vocabulary . . . . .	43
6. Comprehension . . . . .	49
7. Study Skills . . . . .	53
<b>Section IV Reading and English</b>	
8. Teacher Preparation . . . . .	69
9. Assessment . . . . .	75
10. Anticipation and Preparation . . . . .	81
11. Manipulation . . . . .	91
12. Skill Strategies . . . . .	113
13. Study Techniques . . . . .	123
14. Evaluation . . . . .	129
<b>Section V Reading and Social Studies</b>	
15. Teaching Techniques . . . . .	139
16. Understanding Social Studies Materials . . . . .	147
<b>Section VI Reading and Science</b>	
17. Location Skills in Science Reading . . . . .	155
18. Skills in Science Vocabulary . . . . .	159
19. Comprehension of Science Materials . . . . .	167
<b>Section VII Reading and Mathematics</b>	
20. Reading Development in Mathematics . . . . .	179
<b>Section VIII Reading and Home Economics</b>	
21. Reading and Home Economics . . . . .	201
<b>Section IX Materials</b>	
22. Materials . . . . .	213
<b>Section X Evaluation of Reading Programs</b>	
23. Evaluation of Reading Programs . . . . .	257

**Appendix**  
    **Model Programs** . . . . . 269  
**Acknowledgments** . . . . . 275

# Introduction

The middle, junior and senior high school curriculum demands a wide range of reading abilities. The reading program should provide a continuous development of the reading processes initiated in the elementary school so that students can intelligently and effectively deal with the mass of printed media which confronts them daily. The program should emphasize the teaching of reading in the content areas.

Reading instruction should be available to all post-elementary students on a multilevel basis in order to meet their wide range of reading needs. The reading abilities and skills of a student should be identified and evaluated. The student should then be placed in a program that is appropriate for his needs.

In order for the teacher to provide an effective reading program, regardless of the approach adopted, that program must be carried out in a well organized and carefully planned manner. Such planning requires a variety of tools and techniques — tools such as assessment instruments, teaching materials and record and report forms. Techniques include teaching methods for the various reading program objectives such as organizational plans for the effective management of students and facilities and evaluation strategies for determining the overall effectiveness of the program. This guide is designed to provide these tools and techniques.

An effective reading program must be based on a well defined and clearly stated set of reading program objectives. This guide includes an example of a specific set of reading program objectives which may serve as a model for program design. Individual school systems may use these objectives advisedly, making alterations or extending areas that best enhance local needs. While the objectives may vary from one program to another, the critical factor is the commitment of educators toward accomplishing their objectives.

The guide is designed specifically as a practical aid for the teacher. The format was selected for its utility, and the content developed with objectives and activities designed to give the teacher practical teaching ideas. Examples are provided to illustrate the types of materials and ideas described. The guide is not intended to be an end in itself. As meaningful supplementary material relevant to local needs is added, its utility and practicality will increase.

The Indiana concept of what effective reading instruction should be relies heavily on the creativity and unique characteristics of local school communities implementing the State Criteria for Excellence reading model. Thus, foremost concentration is on a variety of teaching/learning strategies and designs to fit individual needs and interests. The loose-leaf notebook was purposefully chosen for the reading curriculum guide because it lends itself to the flexibility and adaptability necessary for modification in meeting the needs of local school systems.

The guide reflects a continuous progress philosophy of reading instruction, a philosophy which will allow each child to progress at his own rate, with the instruction being modified accordingly.

# Developing a Reading Program

A school wants to develop a reading program. What should be done? How is the task begun? In this chapter the "how" to start a reading program and maintain its effectiveness on a continuing basis is discussed. There are definite steps that a school should follow in establishing a reading program. There are also steps to follow in reviewing or evaluating reading programs.

The following chart indicates the steps involved in establishing and maintaining a reading program:

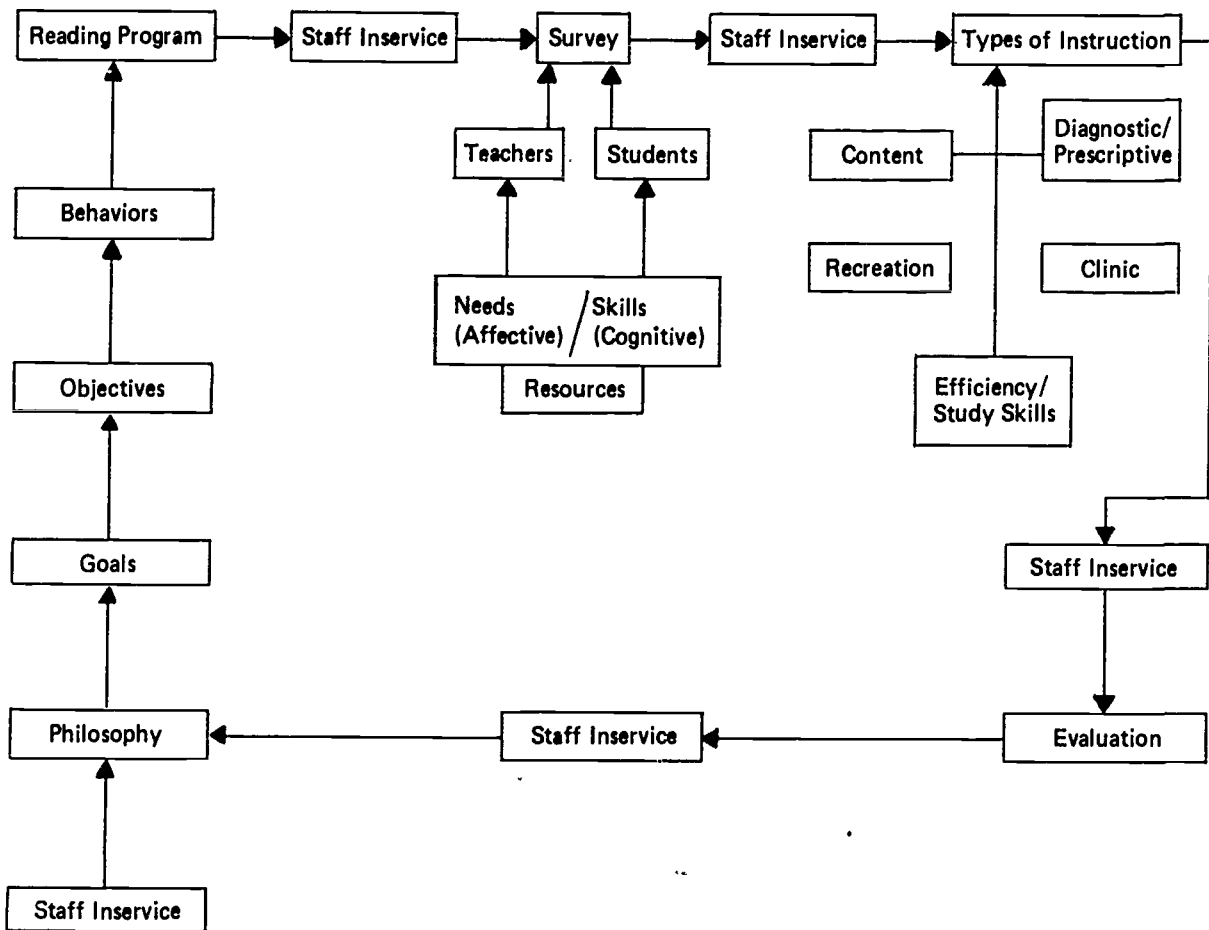

- A. **NEEDS SURVEY.** As indicated earlier, the first step in establishing a reading program is to conduct a school survey. By conducting a survey, a decision can be reached as to the need for the reading program and the kind of program to pursue.

The survey of the school could include the following kinds of information.

1. **Student Needs.** What is the range of abilities of the students in the school? How do they rate on the standardized tests, especially in reading? What program benefits can students of this school and community expect?

2. **Teacher Preference.** Do the teachers of the school want a reading program? What type are they interested in? Do they prefer additional reading personnel? Do they want a program that will help them become better reading teachers in their own discipline?

3. **Teacher Competencies in Teaching of Reading.** Do content area teachers feel they are capable of teaching reading? Do they feel they could improve their teaching with the aid of a reading specialist or reading teacher who could provide leadership in planning and implementing their lessons?

4. **Staff Preference.** Does the development of a reading program have the full support of the total school staff? Is there administrative support? Does the administrator possess leadership and will he provide the assistance necessary to guarantee the success of the reading program?

5. **School Size, Facilities and Materials.** Are the size of the building, the availability of staff and the number of students being taken into consideration in developing a reading program? Is there space available for additional reading rooms? Are there accessible funds to purchase materials and equipment? What facilities (library, media center, audiovisual center) are already available to supplement a reading program? Are there existing materials in the school that could be used in a reading program?

6. **Budget.** Has the administration decided on an estimated budget? After the survey is completed and the school staff has agreed upon establishing a reading program, a committee should be organized to continue the work that needs to be done prior to program commencement. The committee might consist of the principal, the reading consultant/teacher, a teacher from each discipline and any other interested individuals. The committee should reflect the concern of the entire staff.

- B. **PHILOSOPHY AND DEFINITION OF READING.** The second step in developing a reading program is for the school to review its philosophy. Each school must seriously look at its philosophy to see if it is consistent with the philosophy of its teachers, staff, students and community. One of the major ideas in our country is to educate every child to the limits of his learning capacities. The school's philosophy then must reflect the needs of the students in the school. How a school writes its philosophy will in turn affect the types of reading instructional programs to be established.



C. **GOALS, OBJECTIVES AND BEHAVIORS.** The third step in developing a reading program is the writing of goals, objectives and behaviors for the program. In any reading program, the focus should be on the individual, not the group or grade-level performance. The overall program, then, provides a master plan based on specific goals and objectives. The following is an example of a major goal which has four thrusts or instructional types of programs.

GOAL	OBJECTIVE	BEHAVIOR
1. A diagnostic/pre-scriptive reading program.	Students will meet in small classes for the teaching of a systematic reading program by a reading teacher or reading specialist.	Students will perform at a competency level in reading materials and/or workbooks after a lesson has been presented.
2. A content reading program will be provided in the regular classrooms with the aid of the reading teacher/specialist.	Diagnosis will be made to identify students with minor skill problems which can be dealt with in the classroom.	Special assistance will be given to the content area teachers to aid them in teaching these students with reading difficulties.
3. A recreational-leisure program will be provided for students.	Enrichment activities and challenging reading material will be provided for students.	Additional time will be provided for a variety of student recreational reading activities.
4. An efficiency program will be provided for students.	Study skills and speed reading will be taught to small groups of students.	Time will be provided for students to learn to adjust reading speed for specific purposes and to learn specific study skills.

These four thrusts represent an adequate reading program. Many schools may not find all four programs necessary for their situation. An all-school reading program provides for each of the following: (1) a diagnostic-prescriptive study, (2) content area teaching, (3) recreational-leisure reading and (4) efficiency reading.

#### D. TYPES OF INSTRUCTION

1. **Diagnostic-Prescriptive Instructional Reading Program.** A diagnostic-prescriptive program has traditionally been called a developmental reading program. It is a continuing program usually taught by a reading teacher or reading specialist. The reading teacher diagnoses the students' reading difficulties and teaches those who are in need of further skills development. Based on the diagnosis, students are grouped and given special instruction in the skills areas in which they are deficient. Students progress through reading material that sequentially develops reading skills, beginning with the easiest and progressing to the more difficult. A more detailed discussion of diagnosis and prescription is included in Section II.

The reading curricula have certain basic skill areas which should be included in the diagnostic-prescriptive program. These include word analysis, comprehension, study skills and critical reading or thinking skills. A diagnostic-prescriptive reading program will be

different for each school. However, if the school decides on this approach, a reading teacher or reading specialist is usually added to the staff. The reading personnel provide reading instruction to small groups of students during the day. In a diagnostic-prescriptive reading program a separate reading room is usually made available. The reading teacher or specialist prepares his teaching strategies to help students acquire the specific reading skills needed in the content area classroom. Materials are developed and/or purchased to meet the needs of the students.

A diagnostic-prescriptive reading room might look like this:

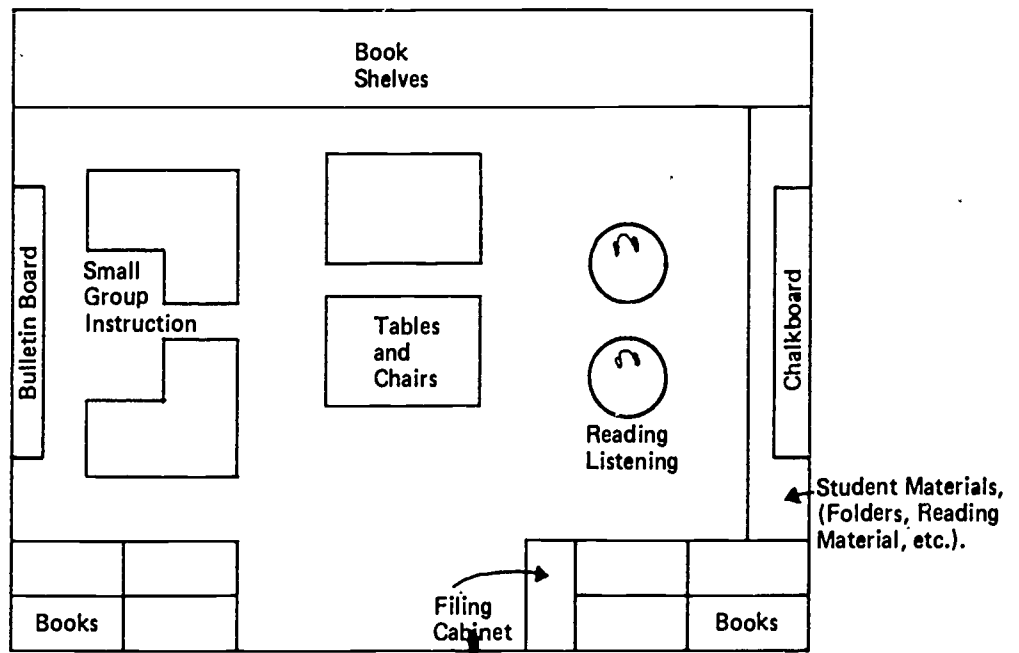

2. **Content Area Instructional Reading Program.** Content area reading is the major thrust of the all-school reading program. In this program the need is for students to read and comprehend textbooks in each of the disciplines offered. Content reading involves diagnosis and prescription. The individual discipline teachers will become the teachers of reading in each of their classrooms. If a reading teacher or specialist is on the staff his duties should include working with both students and with the content area teachers. The reading specialist aids the subject area teacher in diagnosing, prescribing and evaluating students' reading performance. He should provide teachers with information relating to new and important teaching strategies and materials. This person is the coordinator of the content reading program.

3. **Recreational-Leisure Instructional Reading Program.** Another thrust of the reading program is to emphasize recreation or leisure. Students need to be given the time to read for pleasure and to develop reading habits that will extend beyond the school days. Although most schools have libraries for recreational reading, students often fail to utilize this area to its fullest. Separate periods in the school program need to be provided to motivate students and to allow time for "fun" reading. Additional personnel are not needed to implement this reading program in the school. It should evolve as an administrative thrust supported by the entire staff.

4. **Efficiency-Study Skills Instructional Reading Program.** The fourth component of the all-school reading program consists of the efficiency and/or study skills program. Such a program stresses the importance of adjusting reading speed to the purpose for reading and to the types of materials to be read. The types of study skills to be included in an efficiency-study skills program are those which aid pupils in learning, such as SQ3R, PQRST, outlining and note taking. For example, the teacher might help students put into practice skills of the PQRST or the SQ3R approach. PQRST is as follows:

P = preview. Look at chapter and sectional headings, illustrations, summaries and the questions at the end of the chapter.

Q = question. Following the preview, develop questions to guide the reading.

R = read. Keep the questions in mind. See if you can locate the answers.

S = study. Review the information and double check information if you are unsure.

T = test. This is a self-test. Can you answer the guide questions?

The SQ3R is a similar approach: Survey, Question, Read, Recite and Review. The development of reading study skills is included in depth in Section III. The following is an example for the possible arrangement of an efficiency-study skills room.

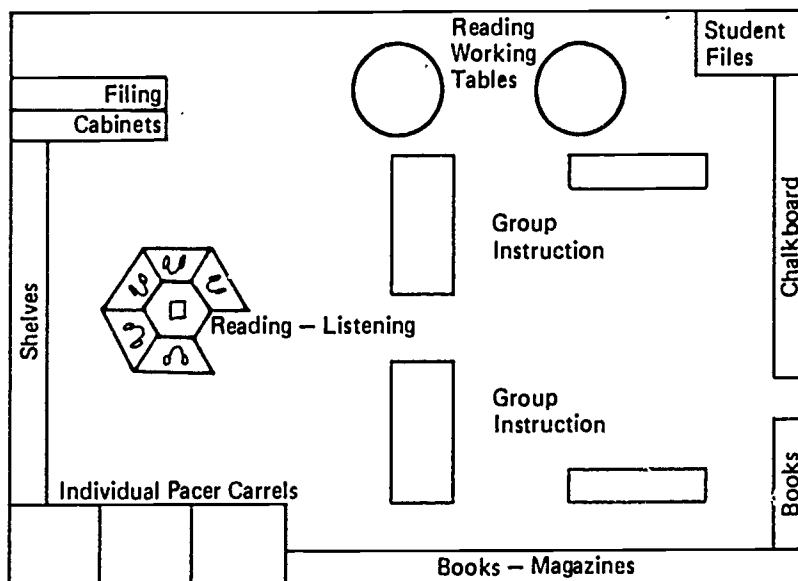

The plan for establishing a total reading program in this section is not meant to serve as a blueprint for every school. A school's reading program must be established to meet the individual needs and differences within that school. There is no comprehensive program which will meet all needs for all school situations. Each school must survey its own situation in terms of its philosophy, goals, objectives and desired student behaviors, then decide on the types of instruction which will best meet its needs.

- D. **INSERVICE AND EVALUATION.** To develop an all-school reading program, an inservice reading program should be conducted for the staff. The staff should decide on their needs, and the reading teacher or specialist should coordinate the inservice programs. Inservice and evaluation are important aspects of the program; both are discussed in later sections of this guide. The success of the reading program can be tentatively determined by the teacher's attitude toward the role of reading in the school and by the student's attitude toward reading. Success can be governed by extrinsic factors such as the interest of the administrators, teachers and community and the school's budget and philosophy.

Some components of an efficient-effective reading program are:\*

1. An integral portion of any reading program should be the inclusion of ongoing needs assessments and evaluative procedures.
2. There should be a coordination of all administrative and instructional facets of the reading program.
3. An effective reading program should be organized to meet individual differences, thereby enhancing continuous progress.
4. There should be provisions for objective instruments which may include criterion-referenced measures to better determine instructional organization.
5. There should be staff commitment to teaching and to pupil learning.
6. There should be parent-community representation and involvement throughout the total reading program.
7. The instructional format should be appropriate to the sophistication of the learner and should encompass special needs and atypical reading problems.
8. The reading program recognizes and accommodates the implications that racial, cultural and sexual differences may have in terms of curriculum, methodology, organization, administration and materials.
9. There should be curriculum adjustments in other subject areas for students who are unable to cope with grade level reading material.
10. There is a defined curricular provision for the gifted and/or high achieving student.

---

\*The Indiana Criteria of Excellence in Reading Programming was established by the Indiana State Reading Advisory Council of the Department of Public Instruction.

11. There should exist readily available quality school and public library resources and services.
12. Provisions should be made within the school to provide and to produce quality instructional materials for distribution to students and teachers.
13. A school's entire teaching staff must be equipped to help students with necessary skills to read more efficiently in the various academic subject areas.
14. Every student in middle, junior high and senior high school should have the opportunity to be involved in a reading program.
15. The reading curriculum should be defined, and information concerning the curriculum should be disseminated to the public.
16. There is ongoing intensive and extensive inservice education for the total certificated teaching, supportive and administrative staff.
17. There should be an ongoing program of preparation in reading for all substitute teachers and noncertificated staff who work in the classroom, such as teacher aides, parent volunteers and auxiliary personnel associated with the school.
18. Each local education agency should have a cadre of instructionally prepared reading volunteers.
19. Reading for enjoyment should be inherent in any reading program.
20. The intellectual, social, physical and psychological factors present within the educational environment are all important and conducive to learning.
21. The reading program recognizes and accommodates the implications that racial, cultural and sexual differences have in terms of curriculum, methodology, organization, administration and materials.

The procedure of developing a reading program indicates that survey and evaluation of the program becomes a continuous process throughout the year. Evaluation leads the school into surveying its needs and into reviewing the philosophy and definition of reading. Goals, objectives and behaviors are re-established, and the type of instruction needed for the school is re-evaluated. Inservice training is then begun to evaluate the new or re-established reading program.

## SELECTED REFERENCES

- Barrett, Thomas C. "Goals of the Reading Program: The Basis for Evaluation." *Elementary Reading Instruction*. Ed. by Althea Berry, Thomas C. Barrett and William R. Powell, 1969.
- Cooper, J. David; Ransom, Peggy E. "Local Concerns." Unpublished Material. Ball State University, 1973.
- Dechant, Emerald. *Reading Improvement in the Secondary School*. Englewood Cliffs, New Jersey: Prentice-Hall, Inc., 1973.
- Otto, Wayne; Smith, Richard J. *Administering the School Reading Program*, Boston: Houghton Mifflin, 1970.
- Schick, George; Schmidt, Bernard. *A Guide to the Teaching of Reading*. Glenview, Illinois: Psychotechnics, Inc., 1973.
- Shepherd, David L. *Comprehensive High School Reading Methods*. Columbus, Ohio: Charles E. Merrill Publishing Co., 1973.

# 2 Techniques for Teaching Reading

Teaching reading effectively depends upon the teacher knowing where each student is in relation to the overall task to be accomplished. The process and techniques involved in finding out where students are in their reading growth and deciding what needs to be done to help them improve their skills has been described under various headings. In this curriculum guide the processes and techniques needed to provide students with a program to meet their needs will be discussed under the heading of diagnostic-prescriptive teaching. The process will be described and techniques and tools which should be helpful to the reading teacher and the content area teacher will be presented. This reservoir of ideas should serve as a basis for each teacher to add to or delete from as the effectiveness of the techniques becomes apparent in each individual program.

- A. **DIAGNOSTIC-PRESCRIPTIVE TEACHING.** Diagnostic-prescriptive teaching of reading is a way of thinking about and organizing for reading instruction rather than a method of teaching reading. The process implies that the teacher will find out where each student is in his reading growth. He will then plan a program which will help the student make optimum improvement in his reading skills. The teacher determines what and how each student will be taught. *The student's needs, not the textbook, determine what will be taught.*

The process of diagnostic-prescriptive teaching of reading involves certain systematic steps. Each step requires the teacher to make decisions concerning the students' reading. The five basic decision-making steps are:

1. Gather relevant background information.
2. Generate a variety of alternative strategies for instruction.
3. Evaluate the alternatives to decide which are most appropriate.
4. Carry out the chosen alternatives.
5. Evaluate the results to determine if more information is needed or new alternatives are needed.

The first step is essentially diagnosing what the student needs. Steps two, three and four are the prescription. Step five insures that the diagnostic-prescriptive process is maintained. The following diagram shows a continuous diagnostic decision-making process with each step leading to another.

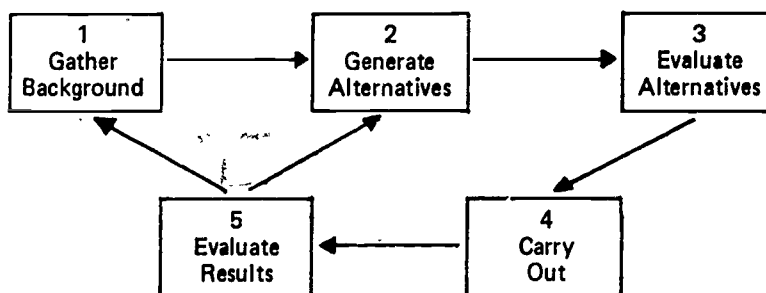

- B. **DIAGNOSTIC DECISION-MAKING PROCESS.** Tests and materials are some tools to serve as a part of diagnosis. Diagnostic teaching, however, implies that some of the diagnosis takes place through teaching with each lesson serving as a diagnostic tool.

One of the major pitfalls of diagnostic teaching occurs when the student's needs are determined and pages in a book are assigned without the necessary teaching being provided. For the most part, materials do not do the teaching; they serve only as a collection of ideas and activities which the teacher coordinates with his own teaching strategies to help the student grow in reading.

Beyond the elementary level, the reading teacher and the content area teacher are responsible for a student's reading growth. The reading teacher is probably more concerned with the student's learning basic reading and study skills while the content area teacher is concerned about the student using his reading skills to learn certain knowledges and skills. Both teachers, using the diagnostic-prescriptive process, can enhance the students' growth in reading. Both teachers need to have certain relevant information about the students' reading and about the teaching of reading in order to base the prescriptions on need.

- C. **RELEVANT INFORMATION NEEDED BY THE READING TEACHER.** To operate a reading program within a diagnostic-prescriptive framework the teacher needs to have some basic information about each student. The six major areas of concern for the reading teacher are: (1) interest and attitude, (2) reading levels, (3) reading skills, (4) capacity, (5) learning mode and (6) other related factors.

Beyond the elementary school level, one of the most significant areas of concern for the reading teacher is the students' interests and attitudes. Techniques and materials used for instruction need to help motivate, increase and maintain the students' desire to want to read.

Considering interests and attitudes becomes a first priority especially with students who have not been successful in learning to read. Students need to see the relevance of what they are being taught as it relates to their life goals. This means using materials and techniques that relate to each student's interests and goals.

A second major area of concern for any teacher is that of the students' reading levels. The teacher needs to know the students' reading levels in order to assign or guide them to materials which they can handle.

The three basic reading levels are:

1. **Independent** — The level where the student is able to function successfully without help.
2. **Instruction** — The level at which the student functions with success, but needs some guidance and instruction.
3. **Frustration** — The level where a student's reading breaks down, and he is not successful with the material.



A student's reading levels are not fixed, absolute points but rather constitute a range which may be influenced by his interest in the material and his motivation for the topic.

The reading teacher also needs to know the student's ability to use certain basic reading skills. This area often requires detailed diagnosis. The reading teacher needs to know the word recognition, comprehension and study skills since this information forms the content core for reading. There is no one absolute continuum of skills. The important factor is that the teacher start with some core listing of skills which can be revised in light of new information.

A student beyond the elementary level may be at almost any point in the development of his reading skills. A student may have the basic word recognition and comprehension skills mastered but needs the higher level comprehension skills of critical reading and study skills.

An understanding of the student's skill development in relation to his reading level is important. Reading level and skill level are not synonymous. A student may be at a particular level but may not show mastery of skills.

Determining the student's capacity for learning to read is also important. Capacity for reading, sometimes called potential or expectancy, is an estimate of what a student should be able to do providing all factors are optimum. The teacher may discover that a student who is a very poor reader may be functioning at his maximum ability. The concept of capacity is somewhat theoretical and should be used only as an indicator.

A factor to consider when working with the reader who is having difficulty learning to read is modality. There are three modes of learning. The visual mode emphasizes characteristics of the word such as length, shape and distinct features. The auditory mode emphasizes symbol-sound associations using some aspects of phonic structural analysis and blending. The kinesthetic mode emphasizes the senses of touch, sight and sound and usually involves tracing, copying and saying of words.

The evidence concerning learning mode does not show that the determination of a student's modality for learning will insure greater success. However, it is an area which the reading teacher should consider when working with students who are having reading difficulty.

The last major area of concern for the reading teacher should be the factors related to reading success, such as vision, hearing, general health, home background and school background. Although these factors are not necessarily causal in nature, they may affect the reader's efficiency.

For a detailed discussion of the six major concerns of reading teachers, refer to the references found at the end of this section.

- D. **RELEVANT INFORMATION NEEDED BY THE CONTENT AREA TEACHER.** The content area teacher needs the same kind of information that the reading teacher needs to help the student grow in reading. The content area teacher is primarily concerned about teaching the skills and knowledges related to a particular area.

- E. **TECHNIQUES FOR GATHERING RELEVANT INFORMATION.** This section presents tests and techniques which can be used by the reading and content area teachers.
- F. **INTERESTS AND ATTITUDES.** Student interests and attitudes may be determined by using two basic procedures. Observation and discussion is one technique. Observing students with their peers will tell much about them. Talking with students about themselves and their interests will help provide needed information.

Inventory is another technique for determining the student's interests and attitude. Using an interest-attitude inventory is a more structured way of gaining information about a student. The two inventories presented here may be used as a part of the more informal observation and discussion. Students can either read and answer the questions or the material can be read to them in an interview-type setting.

## INVENTORY OF PUPIL INTERESTS AND ACTIVITIES

Name \_\_\_\_\_ Age \_\_\_\_\_ Grade \_\_\_\_\_

School \_\_\_\_\_ Date \_\_\_\_\_ Examiner \_\_\_\_\_

1. When you have an hour or two to spend just as you please, what do you like to do best?
  
2. With whom do you like to have fun? Why? When?
  
3. What do you and your friends like to do together?
  
4. What do you like to do alone?
  
5. To what clubs or groups do you belong? Tell about their activities.
  
6. Where have you traveled?
  
7. What kind of movies or television programs do you like the best? Why?
  
8. What stories or kind of books do you enjoy the most? Why are these your favorites?
  
9. Do you like to read? Why or why not?

10. Tell about your home life. What do you enjoy doing with your family?
11. Describe the members of your family so that I would know them if I met them.
12. What regular responsibilities do you have? Tell about them.
13. How do you get your spending money? What do you do with it?
14. Tell about school. What do you like best about it? What do you dislike about it?
15. What do you want to be when you finish school? Why is this your ambition?
16. If you could have three wishes granted, for what would you wish? Why?
17. Of what things are you afraid?
18. What things can you do better than most people?
19. If you could be someone other than yourself, who would you like to be? Why?

## INTEREST INVENTORY RECORD\*

Name \_\_\_\_\_ Date \_\_\_\_\_ Grade \_\_\_\_\_

1. What sports do you like to play? (Circle the answers)  
What sports do you like to watch? (Underline the answer)

- |                   |                     |
|-------------------|---------------------|
| a. Roller skating | e. Basketball       |
| b. Skiing         | f. Swimming         |
| c. Football       | g. Bowling          |
| d. Baseball       | h. Horseback riding |
|                   | i. Boating          |

2. Do you have pets? What kinds? \_\_\_\_\_  
\_\_\_\_\_  
\_\_\_\_\_

3. Do you collect things? \_\_\_\_\_

- |                  |                  |
|------------------|------------------|
| a. Foreign money | d. Butterflies   |
| b. Stamps        | e. Dolls         |
| c. Rocks         | f. _____ (other) |

4. Do you have hobbies and pastimes? (Circle the answers)

- |  |       |
|--|-------|
| a. Writing letters                         | _____ |
| b. Sewing or knitting                      | _____ |
| c. Dancing                                 | _____ |
| d. Singing or playing a musical instrument | _____ |
| e. Playing cards                           | _____ |
| f. Working on cars                         | _____ |
| g. Repairing things                        | _____ |
| h. Drawing and painting                    | _____ |
| i. Driving a car                           | _____ |
| j. Cooking                                 | _____ |
| k. Making things with tools                | _____ |
| l. Experimenting in science                | _____ |
| m. Going for walks                         | _____ |
| n. Fishing                                 | _____ |
| o. Making things                           | _____ |
| p. Other                                   | _____ |

(Comments)

\* J. David Cooper, et. al., *Decision Making for the Diagnostic Teacher* (New York: Holt, Rinehart and Winston, Inc., 1972).

5. Suppose you could have one wish which might come true; what would you wish for? \_\_\_\_\_  
\_\_\_\_\_  
\_\_\_\_\_
6. What school subject do you like best? \_\_\_\_\_  
\_\_\_\_\_
7. What school subject do you like least? \_\_\_\_\_  
\_\_\_\_\_
8. What is the best book you ever read? \_\_\_\_\_  
\_\_\_\_\_  
\_\_\_\_\_
9. Do you enjoy reading? \_\_\_\_\_
10. Do you like someone to read to you? Who? \_\_\_\_\_  
\_\_\_\_\_
11. Apart from lessons, about how much time each day do you spend reading? \_\_\_\_\_  
\_\_\_\_\_  
\_\_\_\_\_
12. Do your parents encourage you to read at home? \_\_\_\_\_
13. What are the names of some books you have been reading lately? \_\_\_\_\_  
\_\_\_\_\_  
\_\_\_\_\_
14. Do you have a card for the public or school library? \_\_\_\_\_
15. How many books do you have of your own? \_\_\_\_\_
16. How many books have you borrowed from friends during the last month? \_\_\_\_\_  
Give titles of some. \_\_\_\_\_  
\_\_\_\_\_  
\_\_\_\_\_

17. How many books have you loaned to friends during the last month? \_\_\_\_\_

Give titles of some. \_\_\_\_\_

\_\_\_\_\_

18. About how many books do you have in your home? \_\_\_\_\_

Give titles of some. \_\_\_\_\_

\_\_\_\_\_

19. From what sources, other than your home, libraries and friends, do you obtain books?

a. Buy them? \_\_\_\_\_

c. Rent them? \_\_\_\_\_

b. Gifts? \_\_\_\_\_

d. Exchange? \_\_\_\_\_

20. What kinds of reading do you enjoy most? (Circle the answer)

a. History

h. Novels

b. Travel

i. Detective stories

c. Plays

j. Fairy tales

d. Essays

k. Mystery stories

e. Adventure

l. Biography

f. Science

m. Music

g. Poetry

n. Other \_\_\_\_\_

21. What kind of work do you want to do when you finish school? \_\_\_\_\_

\_\_\_\_\_

22. What newspapers do you read? \_\_\_\_\_

23. What sections of the newspaper do you like best? (Circle)

a. Sports

d. News

b. Funnies

e. Editorials

c. Stories

f. Other \_\_\_\_\_

24. What magazines are received regularly in your home? \_\_\_\_\_

\_\_\_\_\_

\_\_\_\_\_

25. Name your favorite magazine. \_\_\_\_\_

26. Name the comic books you read. \_\_\_\_\_

27. Where do you get your magazines and comic books? \_\_\_\_\_

\_\_\_\_\_

28. Name some movies you last saw. \_\_\_\_\_

\_\_\_\_\_

29. What are your favorite television programs? \_\_\_\_\_

\_\_\_\_\_

30. Name some other states you have visited (or countries). \_\_\_\_\_

\_\_\_\_\_

31. Which of the following have encouraged you to read? (Circle the answer)

- a. Parents
- b. Teacher
- c. Librarian
- d. Hobby
- e. Friends

- f. Club leader
- g. Relative
- h. Other \_\_\_\_\_



G. **GENERAL READING ACHIEVEMENT.** General reading achievement as measured by a standardized, norms-referenced test indicates how one student ranks in relation to another. The following chart presents some general reading achievement tests available and the areas measured.

<i>Title</i>	<i>Publisher</i>	<i>Skills Measured</i>	<i>Levels</i>
California Achievement Test	California Test Bureau	Vocabulary Comprehension	Junior High Advanced
Durrell Listening-Reading Series	Harcourt Brace Jovanovich, Inc.	Listening Vocabulary Listening Comprehension Reading Vocabulary Reading Comprehension	Advanced 7-9
Gates-MacGinitie Reading Survey E	Teachers College Press	Speed and Accuracy Vocabulary Comprehension	Grades 7-9
Iowa Silent Reading Reading 1973	Harcourt Brace Jovanovich, Inc.	Vocabulary Reading Comprehension Directed Reading Reading Efficiency	Level 1 — Grades 6-9 Level 2 — Grades 9-14
Metropolitan Reading Test, 1970	Harcourt Brace Jovanovich, Inc.	Vocabulary Comprehension	Advanced 7.0-9.5
Nelson-Denny Reading Test	Houghton Mifflin Co.	Vocabulary Comprehension	Grades 9-16
Reading Comprehension Cooperative English E Test	Cooperative Test Division, Educational Testing Service	Vocabulary Speed Level of Comprehension	Grades 7-12
Stanford Reading Tests 1964-65	Harcourt Brace Jovanovich, Inc.	Vocabulary Comprehension	Advanced 7.0-9.9

1. **Determining Reading Levels.** To determine the student's reading level, the teacher can use some type of informal reading inventory (I.R.I.). The I.R.I. is a series of paragraphs graded in difficulty. The paragraphs are usually taken from the content materials. By trying a student out on the material the teacher can determine whether or not the material is suitable for instruction. The I.R.I. can be given orally or silently.

- If given orally, the student reads the paragraphs aloud and answers questions when he is finished. The teacher marks word errors as the student reads aloud.
- If given silently, the student reads the stories to himself and then answers questions orally, thus measuring comprehension.

Normally the teacher needs both the oral and silent I.R.I. to evaluate the students' reading. However, with the students who have mastered the basic word recognition skills, the silent I.R.I. would be more appropriate.

2. **Criteria for Reading Levels.** The criteria presented below for determining a student's three reading levels are based on per cent of word call and comprehension. The percentages presented should be viewed only as rough estimates for the students. They are not fixed, absolute points.

Level	Word Recognition	Comprehension	Behavior
Independent	97%	80%	Reads with ease
Instructional	92-96%	60-79%	Reads with ease
Frustration	Less than 92%	Less than 60%	Shows signs of tension

3. **Marking the I.R.I.** As the student reads aloud the teacher must mark the word and comprehension errors made. The following is one example of a system which may be useful.

*Word Call Errors*

- Omissions - was
- Substitutions - ~~was~~  
~~were~~
- Mispronunciations - tak  
take
- Repetition - was  
~~was~~
- Insertions or addition - was <sup>not</sup> here  
^
- Unknown words - tell pupil to skip and go on

- Punctuation omissions — ( ; )
- Hesitation — the / / / man (one 1/ for each second)

*Silent Reading Difficulties*

- Lip movement — LM
- Head movement — HM
- Finger pointing — FFP
- Vocalization — VOC

4. **Analyzing the I.R.I.** The results of the I.R.I. can give the teacher much valuable information.

- (1) Calculate percentages and determine reading levels on the oral and the silent forms.
- (2) Compare oral and silent scores for discrepancies.
- (3) Analyze word call errors to see what decoding problems a student is having.
- (4) Analyze comprehension question errors to determine needs in terms of main idea, inference, etc.

5. **Modified I.R.I. for Secondary Students.** As mentioned above, I.R.I. should be given both orally and silently. The silent test can be used as a group test by having students read the material and write the answers to the comprehension questions.

6. **Constructing a Content I.R.I.**

- (1) Select 150-300 word passages for the texts available.
- (2) If the difficulty level is not known use one of the readability formulas presented later in this section to determine the difficulty of the material. The material should range from one to three years below grade level to one to three years above grade level.
- (3) Arrange the materials in sequential order of difficulty.
- (4) Write comprehension questions of different types in order to pinpoint the students specific needs. Questions should usually include: 1) vocabulary, 2) main idea, 3) details and 4) inference.

Write approximately 10 true-false, multiple choice and straight answer questions for scoring ease.

7. **Determining Reading Levels.** Another procedure which may be used for determining reading levels is the *cloze* technique. Delete every fifth word in a paragraph. Then have students read the paragraph and write in the word they think fits. For the purpose of scoring, the word they write in must be the *exact* word of the author. This technique allows the content teacher to see if students can read and comprehend textbook material.

# 3 Determining Skill Needs

Specific skill needs of students may be determined in part by using the I.R.I. (Informal Reading Inventory) mentioned previously. However, when more detailed information is needed, other tests and techniques should be used. Presented below are formal and informal procedures for determining skill needs.

## A. STANDARDIZED DIAGNOSTIC TESTS

1. **Diagnostic Reading Scales**, George Spache, California Test Bureau, 1963. Useful for grades 7-12.
2. **Durrell Analysis of Reading Difficulty**, New Edition, Donald Durrell. Harcourt, Brace and Jovanovich, 1955. For the middle school and junior and senior high school.
3. **Gates McKillop Reading Diagnostic Tests**, Aurthur Gates and Anne McKillop, 1962. Teachers College Press. Useful for readers having difficulties in grades 7-12.
4. **Gilmore Oral Reading Test**, John Gilmore, Harcourt, Brace and Jovanovich. Much like an I.R.I. Must be analyzed to determine specific needs.
5. **Gray Oral Reading Test**, William S. Gray and Helen Robinson, Bobbs-Merrill, Inc. Levels 1-adult. Much like an I.R.I. Must be analyzed to determine specific needs.

B. **INFORMAL TEACHER-MADE TESTS.** One of the best ways for the teacher to determine specific skill needs of students is through the use of informal teacher-made tests. These tests can be based on the content of specific areas and can tell teachers whether or not the student is able to use the skills related to the area.

C. **DETERMINING CAPACITY FOR READING.** Two basic procedures are available for estimating a student's reading capacity. These procedures are listening tests and capacity formulae.

# 4 Organizing for Instruction

Once the teacher has gathered all the pertinent information on the students, there is a need to effectively organize it. Some plan of organization will be needed to meet the needs of the students.

- A. **ORGANIZING INFORMATION.** The information gathered on each student may be organized by setting up a folder, using a checklist or a card. The content teacher may not need the detailed information that the reading teacher will want. The three procedures which follow are suggestions which can be used by the reading teacher or the content teacher.

### *Sample 1*

This card may be used by the content area teacher. Spaces are provided to note levels and skill strengths and needs. Additional information may be added in the space provided. This card should help the teacher when organizing plans for each unit of work.

---

Name \_\_\_\_\_

*Reading Levels*

*Skill Strengths*

Independent \_\_\_\_\_

Instructional \_\_\_\_\_

Frustration \_\_\_\_\_

*Comments*

*Skill Needs*

---

### *Sample 2*

---

Name \_\_\_\_\_

*Reading Levels*

Independent \_\_\_\_\_ Instructional \_\_\_\_\_ Frustration \_\_\_\_\_ Capacity \_\_\_\_\_

*Prereading*

Letter names	Initial consonants	Prefixes	Details
Visual discrimination	Final consonants	Suffixes	Main idea
Auditory discrimination	Blends	Endings	Sequence
Left-right	Digraphs	Compounds	Inference
Listening	Long vowels	Syllables	Dictionary
Speaking vocabulary	Short vowels	Comprehension- study skills	Table of contents
Oral sentence structure	R-controlled vowels	Vocabulary	Index
	Vowel general	Context	Maps
	Diphthongs		Graphs

*Word Recognition*

Sight vocabulary \_\_\_\_\_

*Sample 3*

READING SKILLS CHECKLIST

Name \_\_\_\_\_ Age \_\_\_\_\_

<i>Reading Levels</i>	<i>Date</i>	_____	_____	_____	_____	_____
Independent		_____	_____	_____	_____	_____
Instructional		_____	_____	_____	_____	_____
Frustration		_____	_____	_____	_____	_____
<i>Capacity</i>		_____	_____	_____	_____	_____

*Standardized Test  
Data*

*Specific Skills*

M – mastered; T – taught, not mastered; P – additional practice after mastery, NT – not tested

*Prereading*

Letter names	_____	_____	_____	_____	_____	_____
Visual discrimination	_____	_____	_____	_____	_____	_____
Auditory discrimination	_____	_____	_____	_____	_____	_____
Left-right	_____	_____	_____	_____	_____	_____
Listening	_____	_____	_____	_____	_____	_____
Speaking vocabulary	_____	_____	_____	_____	_____	_____
Oral sentence structure	_____	_____	_____	_____	_____	_____

*Word Recognition*

Sight vocabulary (level)	_____	_____	_____	_____	_____	_____
Initial consonants	_____	_____	_____	_____	_____	_____
Final consonants	_____	_____	_____	_____	_____	_____
Silent consonants	_____	_____	_____	_____	_____	_____
Blends	_____	_____	_____	_____	_____	_____
Digraphs	_____	_____	_____	_____	_____	_____
Long vowels	_____	_____	_____	_____	_____	_____
Short vowels	_____	_____	_____	_____	_____	_____
R-controlled vowels	_____	_____	_____	_____	_____	_____
Two vowel rule	_____	_____	_____	_____	_____	_____
Medial vowel rule	_____	_____	_____	_____	_____	_____
Vowel-consonant rule	_____	_____	_____	_____	_____	_____
Open syllabication rule	_____	_____	_____	_____	_____	_____
Diphthongs	_____	_____	_____	_____	_____	_____
Prefixes	_____	_____	_____	_____	_____	_____
Suffixes	_____	_____	_____	_____	_____	_____
Endings	_____	_____	_____	_____	_____	_____
Compounds	_____	_____	_____	_____	_____	_____
Contractions	_____	_____	_____	_____	_____	_____
VCC rule	_____	_____	_____	_____	_____	_____
VCV rule	_____	_____	_____	_____	_____	_____
-le rule	_____	_____	_____	_____	_____	_____
Affix rule	_____	_____	_____	_____	_____	_____

*Comprehension-Study Skills*

Vocabulary	_____	_____	_____	_____	_____	_____
Context clues	_____	_____	_____	_____	_____	_____
Literal – details	_____	_____	_____	_____	_____	_____
main idea	_____	_____	_____	_____	_____	_____
sequence	_____	_____	_____	_____	_____	_____
Inferential	_____	_____	_____	_____	_____	_____
Critical/evaluative	_____	_____	_____	_____	_____	_____
Dictionary	_____	_____	_____	_____	_____	_____
Table of contents	_____	_____	_____	_____	_____	_____
Index	_____	_____	_____	_____	_____	_____
Maps	_____	_____	_____	_____	_____	_____
Graphs	_____	_____	_____	_____	_____	_____

*Comments*

- B. **ORGANIZING THE CLASSROOM.** In order to meet the needs of all students some type of organizational plan must be developed to be used in the classroom. The type of plan will depend on the teacher and his skill. The most important point to keep in mind is that the plan must allow for the individual needs of students.

The reading teacher working in separate reading classes will want to organize around both

the students' reading levels and skill needs. Two basic steps should be followed when organizing within the reading class.

1. Organize by reading level.
2. Organize by skill needs within each reading level. Be cautious. Do not separate skills. Students must use their word attack skills in relation to the contextual material.

Many other plans for organization are discussed in the references presented at the end of this section.

In the content classes, organization will operate a little differently. The main concern for the content teacher is that the student be given tasks that will require him to utilize his reading strengths. Weaknesses which need to be overcome may also be dealt with, but the place to begin is with the student's strengths.

The following steps should be helpful in organizing the content classes:

- (1) Decide on the unit of work to be studied.
- (2) Identify content to be learned. Make a list of terms which may need to be taught.
- (3) Examine the class in terms of reading levels and skill needs. Look at skill strengths. Make a tentative grouping plan. Put all of those together who have the same reading level or the same skill strength.
- (4) Determine the activities needed to teach the content and at the same time utilize what each student has in reading. This may mean doing some of the following:
  - Setting up groups by level, skill strength or need.
  - Developing differentiated study guides for students with different needs.
  - Locating multiple texts for the unit to be used by students at different reading levels.



## SELECTED REFERENCES

- Blanton, William; Farr, Roger, and Tuinman, J. Jaap, eds. *Reading Tests for the Secondary Grades: A Review and Evaluation*. Newark, Del.: International Reading Association, 1972.
- Bond, Guy L., and Tinker, Miles A. *Reading Difficulties: Their Diagnosis and Correction*. New York: Appleton-Century-Croft, 1973.
- Burmeister, Lou E. *Reading Strategies for Secondary School Teachers*. Reading, Mass.: Addison-Wesley Publishing Co., Inc., 1974.
- Dawson, Mildred. *Developing High School Reading Programs*, Newark, Del.: International Reading Association, 1967.
- Dechant, Emerald, ed. *Detection and Correction of Reading Difficulties*. New York: Appleton-Century-Crofts, 1971.
- Early, Margaret J., ed. *Reading Instruction in Secondary Schools*. Newark, Del.: International Reading Association, 1969.
- Gallant, Ruth. *Handbook in Corrective Reading: Basic Tasks*. Columbus, Ohio: Charles E. Merrill Publishing Co., 1970.
- Harris, Albert J. *How to Increase Reading Ability*. Fifth Edition. New York: David McKay Co., Inc., 1970.
- Harris, Larry A., and Smith, Carl B. *Reading Instruction Through Diagnostic Teaching*, New York: Holt, Rinehart and Winston, Inc., 1972.
- Herber, Harold L., ed. *Developing Study Skills in Secondary Schools*. Newark, Del.: International Reading Association, 1965.
- Herber, Harold L. *Teaching Reading in Content Areas*. Englewood Cliffs, N.J.: Prentice-Hall, Inc., 1970.
- Kaluger, George, and Kolson, Clifford J. *Reading and Learning Disabilities*. Columbus, Ohio: Charles E. Merrill Publishing Co., 1969.
- Mangrum, Charles T., ed. *Teaching Reading Skills Through the Newspaper*. Newark, Del.: International Reading Association, 1971.
- Robinson, H. Alan, and Rauch, Sidney J., eds. *Corrective Reading in the High School Classroom*. Newark, Del.: International Reading Association, 1966. Reading Association, 1966.
- Shepherd, David L. *Comprehensive High School Reading Methods*. Columbus, Ohio: Charles E. Merrill Publishing Co., 1973.
- Thomas, Ellen Lamar, and Robinson, Alan H. *Improving Reading in Every Class*. Abridged Edition. Boston, Mass.: Allyn and Bacon, Inc., 1972.
- Viox, Ruth G. *Evaluating Reading and Study Skills in the Secondary Classroom*. Newark, Del.: International Reading Association, 1968.

Wilson, Robert M. *Diagnostic and Remedial Reading for Classroom and Clinic*. Columbus, Ohio: Charles E. Merrill Publishing Co., 1972.

Zintz, Miles V. *Corrective Reading*. Second Edition, Dubuque, Iowa. William C. Brown, 1972.

# 5 Vocabulary

The basic reading skill areas are extremely important aspects of the all-school reading program. These reading skill areas become even more vital to students as they proceed from the elementary to the secondary program. There are three main reasons for the increased value of these basic reading skills: (1) content material increases in sophistication and difficulty, (2) more independent study is required by the secondary student, and (3) the student must learn a greater quantity of content material at a faster pace.

The first task for improving reading skills at the post-elementary level is for teachers to become convinced that teaching reading skills enhances the students' ability to learn more readily within their particular content area. Knowledge of the basic skill program must be understood and applied by the content teachers if the achievement level of the school's reading program is to be increased. This section of the guide provides information about three general skill areas: vocabulary, meaning and study skills.

- A. **AREAS OF VOCABULARY DEVELOPMENT.** Content teachers will agree that vocabulary competence is the key to the student's mastery of the content subjects. This makes it necessary for the content teacher to understand the development of the vocabulary skills. The following diagram illustrates the four different areas of vocabulary development:

<i>Input</i>	<i>Output</i>
Reading Vocabulary	Speaking
Listening Vocabulary	Writing

Children vary in their development of speaking and listening vocabularies before entering school. The degree of listening and speaking skills developed before formal schooling has a profound effect on further vocabulary development as the child progresses through school. Usually the reading and writing vocabulary skills that the child develops is the responsibility of the school curriculum. The primary type of vocabulary developed before school and in the early elementary grades is labeled general vocabulary; however, general vocabulary continues to develop throughout the student's school program.

The size of the pupil's general vocabulary continues to develop throughout his life. He also develops a specific vocabulary as he progresses through the curriculum. The content teacher is a key figure in expanding a pupil's general and specific vocabulary.

- B. **TYPES OF VOCABULARY DEVELOPMENT.** The vocabulary of the content areas is divided into three types: general, specific and nonspecific.

1. **General Vocabulary.** The first vocabulary mastered by the student is his general vocabulary. This vocabulary consists of high frequency words utilized in all fields of communication. In reading, a general vocabulary list that is often utilized is the Dolch List of 220 Words. This list contains common words such as "the," "and," "them," "when," etc., which comprise a high percentage of running words in the beginning

reading. Other lists of high frequency words are Dale's List of 769 Words, Stone's revision of Dale's List and Thorndike's List of 10,000 Words. If the student has trouble with high frequency general vocabulary words, specific vocabulary words will present even greater difficulty. General, as well as specific vocabulary, needs to be developed by the content teacher. Hopefully, the post-elementary student possesses an adequate core of general vocabulary words. If he does not, the specific vocabulary will be temporarily delayed in the reading and writing vocabulary areas until the deficiency can be corrected.

2. **Specific Vocabulary.** Usually specific vocabulary is begun in the 3rd grade, when the child begins to read independently in the content areas, and continues throughout school. The specific vocabulary is peculiar to each content area and may not be part of the student's listening, speaking, writing or reading vocabulary. The student then has the task of learning words that are often more difficult and time consuming than general vocabulary. Specific vocabulary requires many levels of concept development and abstract thinking which requires additional teaching time for their development.

3. **Nonspecific Vocabulary.** Nonspecific vocabulary does not fit neatly in either of the first two types. This includes words that have different meanings when used in different content areas such as colloquial, allusive, ambiguous and referential vocabulary.

C. **VOCABULARY DEVELOPMENT.** The program for vocabulary development initiated in the elementary school has to be expanded by the middle school, junior high and senior high school content area teacher. Specific vocabulary skills for each particular content area must be emphasized. As part of readying the class for the teaching selection, background concepts and vocabulary development are among the first tasks which the content teacher should consider. These two tasks are interrelated and many activities apply to both. Audiovisual aids such as films, filmstrips, bulletin boards, pictures, strip charts, concrete objectives, chalkboard activities, tape cassettes and overhead projectors can be used.

1. **Core Word Lists.** One method to determine what specific vocabulary is needed for a class is to pretest each unit with a vocabulary test. This informs the content teacher which specific words need to be emphasized and gives the teacher an estimate of the vocabulary level of the class. It also informs the student as to which words he needs to study and which words he has already mastered. If the vocabulary level of the class is low, the pretesting of future specific words becomes a waste of time.

Each content teacher should have in mind what specific reading, listening and speaking vocabulary words are most important for the concept development of the unit. These words then become the specific vocabulary that the student needs to retain. They act as a core list from which future concepts and additional specific vocabulary can be enlarged. A second or even third list of specific vocabulary words should be kept in reserve and presented as soon as the first list is mastered by the class.

From this specific core list, specific writing vocabulary words can be selected, which involves additional time for spelling activities. The specific words selected for spelling instruction should be used frequently in writing exercises if time is to be allotted for spelling mastery. It would be a waste of the student's time and effort to learn to spell words that are not used for writing purposes or not used in the content areas.

A team of teachers meeting from each content area may want to determine what specific

core vocabulary should receive the most emphasis during the semester. Additional lists in decreasing importance also could be compiled. These core lists could be shared to help determine permanency, content spread and frequency of the specific vocabulary lists. This may involve a long-range planning effort encompassing a two-year span.

A specific core list could also be used by a reading teacher in diagnostic/prescriptive reading to reinforce specific vocabulary skills for the content teacher. If a reading teacher is available, this specific core list can be used most effectively to strengthen the vocabulary skills of students who need additional time for learning. The vocabulary list can be reproduced and used as a student worksheet.

**2. Word Recognition Skills.** Word recognition skills have varying importance in the content areas. If the level of general class vocabulary is low, word attack skills may need to be emphasized. The four methods used in word identification are the use of context, phonics, structural analysis and the dictionary.

The contextual word attack skill centers on the student's ability to use meaning to help unlock the unknown word. The student may be able to pronounce the word and may know at least one meaning of the word. Using context clues will enable the student to think of several words that would make sense in the sentence. If the context clues are insufficient to help the student unlock the word, he must resort to phonic and structural analysis clues. The student who can combine contextual clues with phonics clues will attain a high proficiency for decoding words.

Phonics is the teaching of speech sounds for letters and groups of letters. Overuse of phonics skills can cause slow, laborious reading if the student continues to use phonics skills to attack words that should be part of his instant word recognition vocabulary. Phonics skills rely on the correspondence between the printed symbol and the speech sounds represented by them. This method of word recognition may present auditory discrimination problems for the secondary student. Techniques involving visual recognition skills may be an easier and more interesting way to approach phonics in the secondary school. Visual clues consist of recognizing root words, affixes, endings and syllabication patterns that are usually taught in structural analysis. A student who has poor visual memory has extreme reading difficulties and may have to rely on the phonic method to build a general reading vocabulary.

Structural analysis involves knowledge of root words, affixes (suffixes and prefixes), word endings, compared words, accents, homographs and syllabication. These skills are helpful in reading and writing activities. The structural analysis skills that post-elementary teachers include most frequently in their vocabulary instruction are affixes to the root word or Latin and Greek root words. A brief list of common Latin and Greek roots is provided below:

<i>Root</i>	<i>Meaning</i>	<i>Derivatives</i>
aud-	hear	audible
bibl-	book	bibliotherapy
bio-	life	biography
clar-	clear	clarification
corp-	body	corporate
dic-, dict-	say	dictate
dynam-	power	dynamo
geo-	earth	geology

<i>Root</i>	<i>Meaning</i>	<i>Derivatives</i>
hetero-	different	heterogeneous
micro-	small	microcosm
photo-	light	photosynthesis
tele-	far	telephone

A more complete listing of Latin and Greek roots is contained in David Shephard's book, *Comprehensive High School Reading Methods* (Columbus, Ohio: Charles E. Merrill Co., 1973).

## SELECTED REFERENCES

- Aukerman, Robert C. *Reading in the Secondary School Classroom*. New York: McGraw-Hill Book Co., 1972.
- Fry, Edward. *Reading Instruction for Classroom and Clinic*. New York: McGraw-Hill Book Co., 1972.
- Shepard, David L. *Comprehensive High School Reading Methods*. Columbus, Ohio: Charles E. Merrill Publishing Co., 1973.
- Thomas, Ellen Lamar, and Robinson, H. Alan. *Improving Reading in Every Class*. Boston: Allyn and Bacon, Inc., 1972.

# 6 Comprehension

- A. **RATE OF READING.** Reading rate depends upon mental ability, reading skills, familiarity of the content, difficulty of the material, and the purpose for reading a selection. There is no one rate of reading that is appropriate for all situations; rather, the mature reader varies his rate according to his purpose and to the requirements of the material.

The different types of reading rates will be labeled in this guide as skimming, rapid reading, normal reading and careful reading. Each type will include the kinds of reading situations to which they are appropriate.

1. **Skimming.** One purpose for reading a selection rapidly is to get a general overview of the material. Skimming may include looking at the topic and subtopic headings or reading the first two or three lines of each paragraph in the selection. Survey skimming may be helpful in answering a specific question. It is also useful in identifying and clarifying certain concepts that need to be developed. Survey skimming may be the first step in utilizing the SQ3R method. The Survey, Question, Read, Recite and Review method is discussed in detail in Section 1, Chapter 5, of this guide. Skimming a selection can help in the organization of notes taken during a lecture or during a class discussion.

Scanning, the locational part of skimming, is a procedure used to quickly locate specific words, details and names that appear in the selection. Scanning is used in reference work with dictionaries, atlases, encyclopedias, almanacs and directories. This skill can be utilized by the content teacher in selecting a vocabulary core list or in determining whether the textbook provides definitions for key words.

2. **Rapid Reading.** Rapid rate is similar to skimming but requires the reading of main ideas in more detail. It is useful as a review of previously read material in order to summarize, generalize and formulate new questions on the material. A rapid reading rate is also useful when reading narrative material primarily for plot and when reading informational material for pleasure and relaxation.

3. **Normal Reading.** The normal reading rate is used by students in preparing for daily assignments. Students need to be able to read with optimum speed and concentration to obtain the greatest possible understanding. The normal rate of reading is useful when finding specific answers, noting details, solving problems, grasping relations of details to main ideas and comprehending directions. A normal rate of reading is recommended in order to appreciate the beauty of a literary style.

4. **Careful Reading.** A careful reading rate is reflective, therefore causing it to be slow and deliberate. The student using this rate will pause to: compare and contrast, read material with unusual vocabulary and style, analyze the author's presentation and recall, associate and judge literary value.

The content teacher should encourage students to read at their optimum rate without loss in comprehension. Students need to know and practice different rates for different purposes in order to sharpen study habits and to increase comprehension.



## B. PROBLEMS RELATING TO MEANING DIFFICULTIES

1. **Paragraphs.** The sentence is our basic thought unit, but the relationship of sentences to one another in a paragraph may prove to be the stumbling block to meaning. Discussing different kinds of paragraphs included in textbooks is time well spent.

One type of paragraph is the topic or introductory paragraph found in the beginning of the reading selection. The paragraphs following are usually developmental, explaining and clarifying the topics presented in the initial paragraph.

Some paragraphs are used to make a smooth transition from one topic to another. Other types of paragraphs that need explanation or discussion are summary paragraphs, narrative paragraphs, descriptive paragraphs, definitive paragraphs and problem-solving paragraphs. Many students have not learned these paragraph types. A content area teacher can improve a pupil's comprehension skills by illustrating the different types of paragraphs that are frequently encountered in content areas.

2. **Main Ideas and Details.** A paragraph usually has two factors: (1) the main idea being expressed and (2) what is being said about the thing or idea.

There are many patterns paragraphs may take in terms of main ideas and supportive details. The topic sentence may be: (1) the first sentence of the paragraph, (2) it may be found any other place in the paragraph and (3) it may be an implied topic without having an actual topic sentence.

Instruction should begin with a topic sentence followed by supportive details. These are usually easier for the student to comprehend. If the student has to read the entire paragraph before he finds the topic, the paragraph's meaning may be diminished or obscured. The following are a few paragraph patterns that might be used in instructional lessons.

Main idea – supportive details.

Supportive details – main idea last.

Main idea – supportive details – main idea restated.

Supportive details – main idea – supportive details.

Supportive details – main idea implied.

The students working with varied pattern paragraphs should be, after instruction, able to write paragraphs in the various patterns.

3. **Using Context.** Many students do not use context clues as a technique for determining the meanings of unfamiliar words. The content area teacher should illustrate the importance of key words or phrases before or after the unknown word to aid in determining meaning. There are two different uses of context in determining the meanings of words and in decoding words. The student can use contextual meaning signals to decide which meaning of the word he should use, or he may have to use key words to help determine an unfamiliar meaning of the word.

4. **Using a Dictionary.** Students often seem reluctant to use a dictionary in their school work. There are times, however, when context clues do not aid the student in determining meaning and when dictionary skills become necessary. Usually English teachers review dictionary skills, but if the content teacher expects students to utilize the

dictionary, then he should also give class instruction in dictionary skills. The following are examples of dictionary skills: (1) alphabetizing through the fourth letter of a word, (2) use of guide words at the top of each page, (3) selecting a specific meaning and (4) usage level.

The following is an example of a typical dictionary exercise.

- ( 1) What is an entry word?
- ( 2) If more than one spelling is given for a word, how do you determine which one is preferable?
- ( 3) How can you distinguish an American spelling from a British spelling?
- ( 4) How does your dictionary distinguish a foreign word from an English word in its entries?
- ( 5) What principle determines the inclusion in your dictionary of various pronunciations of a single word.
- ( 6) If more than one pronunciation is given for a word, what principle will determine which one you should follow?
- ( 7) What is etymology?
- ( 8) What is a usage label?
- ( 9) What are inflectional forms?
- (10) What are you to assume about a verb which has no inflectional forms listed?
- (11) What is a cross reference and how is it indicated in your dictionary?
- (12) Check the syllabication of each of these words, first as given at the entry and then as given in parentheses later in the entry:
  - recrudescence
  - Machiavellian
  - intuition
  - enteritis

If different syllabications are found, explain why.

- (13) What word in modern English comes from the ancient name of the Menderes River?

5. **Topographical Signals.** When a person speaks, meaning is determined by voice intonations or word stress. In reading, certain punctuation and topographical signals are used to help convey the author's meaning. The following recommendation can be used to guide students in paying more attention to punctuation marks and certain topographical signals while reading.

- (1) Use periods as a signal to think through the falling inflection used at the end of a spoken statement. Use a question mark as a signal to think through the falling, and sometimes rising, inflection used at the end of a spoken question.
- (2) Use exclamation marks as a signal to indicate strong feelings. What has happened or what has been said in the passage indicates the particular strong feeling to be thought.
- (3) Use commas as a signal to think through the short pause separating the items in a series, for separating an appositive or the names of persons addressed from the rest of the sentence, and for keeping the sense of an introductory dependent clause separated from the sense of the immediately following words.
- (4) Use a dash between words as a signal to think through a pause which is a little longer than the pause for a comma.
- (5) Use a dash or a row of dots before the end of a story character's speech as a sign that another speaker or some event has interrupted the speech or that the speaker has decided not to finish.
- (6) Use colons as a signal to indicate that what is coming next explains what has just been said.
- (7) Use apostrophes as a signal to indicate possession.
- (8) Use italics, boldface type or full caps to signify strong emphasis.
- (9) Use quotation marks to express the name of a story, song or poem.

# 7 Study Skills

A. **BASIC STUDY SKILLS.** Common study skills are introduced in the elementary school, but need additional instruction at the post-elementary level. The four basic study skills presented in this section are: library and locational, selection and evaluation, organization and retention.

1. **Library and Locational Skills.** The librarian is usually the person who teaches the library reference skills needed for using specialized sources and special aids. If the content area teacher wants to develop locating information skills for his particular text, the following outline may be useful. Teaching items concerned with *locating information*:

(1) References needed for using printed aids inside a single volume:

Title.

Table of contents.

Any aids useful for finding information in that particular book – maps, tables, figures, illustrations.

Index (most helpful resource of all).

- Key words (the most difficult of index skills).
- Alphabetical order.
- Main topics.
- Subtopics.
- Cross-reference.

(2) References needed for using specialized sources such as encyclopedias, atlases and yearbooks (e.g., the *World Almanac*).

(3) References needed for using special aids such as *Readers' Guide to Periodical Literature*, the library card file and the educational index.

(4) References needed for locating quickly on a page the information referred to by an index through the use of topic headings or through reading the first two or three sentences to see if the information is contained in the paragraph.

2. **Selection and Evaluation.** This is probably the most difficult of all study skills to instruct. This is a thought-processing skill that produces varying degrees of success. The high achieving student will often copy more from a selection or change the sentence structure than a low achieving student. The following may be useful when teaching selection and evaluation:

(1) Determining relative importance of the statements depending on the purpose for reading.

- Which contributes the most necessary information.
- Which will be most interesting to my audience.
- Which is the most appropriate to the subject.

(2) Determining the validity or truthfulness of printed statements.

- Question truthfulness of the printed statement.
- Check on the validity of a statement which is questioned.
  - Judge from personal experience.
  - Look up topic in index and find other places where the author tells about the topic to see if he is consistent.
  - See if other authors agree.
  - Is the author competent to write on this topic? Check his background.
  - Is this material fact or opinion?
  - Are any propaganda techniques employed by the author?

3. **Organization.** The organization of material depends on lessons dealing with the understanding of main ideas and supportive details. Organizational skills also include the ability to outline, to take notes and to make summary paragraphs. The following outline may be useful to check or expand a student's understanding of organizational skills.

(1) Teach what is meant by topics, subtopics and details.

- Topic – a good paragraph talks about only one thing or idea.
- Subtopic – main points about the topic.
- Details – use subtopics as how or why questions to find details.

(2) Teach outlining skills with emphasis on putting ideas in proper order.

- Read the title and think of a question the material should answer.
- Read the material to get answers to the questions.
- Write these answers as main topics in the outline.
- Check to see if good points have been chosen as main topics.
- Read the main topics and think of questions you expect the material to answer.
- Read the material to get answers to the questions.
- Write the answers as subtopics under each main topic.
- Check to see if good topic points were chosen as subtopics.
- Read subtopics and think of questions the material should answer about the subtopics.
- Read to get answers to questions.
- Write the answers as details.
- Check to see that you have chosen good points for details.

(3) Teach the making of a summary paragraph.

- First sentence should tell the subject of selection.
- Each sentence should give one of the main points.
- The sentences should be arranged in proper order.

(4) Teach note taking on material read.

- Read once before taking notes.
- Number the notes while taking them.

- Clue each note so it can be referred to again.
- Don't take more than one note on identical informaton.
- Don't write notes on information you don't understand.
- Take notes only on those parts which relate to the topic or questions.
- Make notes sufficient so you can recall what the source said.
- Organize the notes by topics, subtopics and details.

4. **Retention Skills.** The amount of retention required of the student depends largely on the purpose and dictates set by the content area teacher. The organizational study skills determine what ideas are going to be emphasized by the student. A good job of organization will make retention easier. The following outline could be used as a guide of things to be stressed by the teacher:

- (1) Teach students to select ideas and to remember through the use of a study guide.
- (2) Hold students responsible for main ideas and important supportive details.
- (3) Teach ways of retaining such as:
  - Writing questions covering the selection.
  - Paraphrasing (expressing the same ideas without using exact words).
  - Taking notes.
  - Outlining.
  - Writing a summary paragraph.

## B. STUDY PROCEDURES

1. **Survey, Question, Read, Recite and Review — SQ3R.** Many students have developed their own study techniques and approaches to content material. These students may do an outstanding job in studying informative material using different methods; however, there are also many students who need additional instruction for studying. The SQ3R method by Robinson is one of several which can be utilized for self-instruction.

The purpose of the following SQ3R outline is to make available a program that could be duplicated for each student to use as a guide for studying textbook chapters. Passing out copies of the SQ3R method to each student will not accomplish the objective of SQ3R. Additional time must be allotted to use this strategy as a class project for several units. The teacher's guidance and motivation are needed to make this technique habit-forming. The following is the outline form of the SQ3R method:

- I. *Surveying* provides a general picture of what will later be studied in detail.
  - A. First survey the whole book.
    1. Read preface, forward and other materials addressed to the reader.
    2. Study the table of contents.
    3. Leaf through the book.
      - a. Read summaries.
      - b. Glance at headings and topic sentences.
  - B. Before reading each chapter, survey it.

1. Read over the headings.
  2. Reread the summary.
- II. *Questions* help learning by giving it a purpose.
- A. Keep asking your own questions.
    1. First write them down.
    2. Later do it mentally after it becomes an ingrained habit.
  - B. Use questions asked by the author.
    1. In the textbook.
    2. In a student's workbook if there is one.
- III. To *read* most effectively, you should do the following:
- A. Read actively, not passively, asking yourself what you have learned.
  - B. Note especially important terms.
  - C. Read everything, including tables, graphs and other illustrative materials.
- IV. *Recitation* is a well-established aid to learning.
- A. It should be done while reading a book in order to remember what is read.
  - B. Amount of recitation depends on kind of material.
    1. Up to 90 or 95 per cent of study is for memorizing disconnected, not-too-meaningful material such as rules, items, laws or formulas.
    2. As little as 20 or 30 per cent for well organized story-like material such as literature, history or philosophy.
  - C. Recitation should be done as follows:
    1. Section by section in reading the book.
    2. In general, immediately after first learning.
- V. *Reviewing* consists of the steps above and the following:
- A. Especially resurveying the headings and summaries.
  - B. Rereading, but primarily to check yourself on how well you can recite.
  - C. Reviewing should be done at those times:
    1. Immediately after studying something; then it should be fairly brief and consist mainly of recitation.
    2. Once or twice in between the first and final review, when it should emphasize rereading.
    3. Intensively in a final review in preparation for an examination when it should emphasize recitation.
2. **Kinds of Reports.** The three types of reports required of students for school course work are experience, opinion and topic reports. Content area teachers should not assume that students can automatically produce the quality of reports desired. The teacher who

instructs students in preparing reports will be rewarded with a higher degree of class achievement. The following brief description of each type of report and the list of lessons are intended to aid the content area teacher in helping students to prepare reports.

- (1) **Experience Reports.** Experience reports are the first kind of reporting required in the elementary school. An example of this is the "show and tell" activity. This type of report is usually given orally and used throughout life. It is a method of relating ones experiences incurred through daily living. Because students are eager to tell parents what has happened at school, the best public relations between school and community come about through the experience reports students give at home.
- (2) **Topic Reports.** Topic reports begin usually in the middle grades when more information is required by content area teachers. It is the most commonly used report during the student's school years. These reports may be presented either orally or in written form. Topic reports vary from copying information without any learning taking place to organized reports with a great deal of learning occurring. The content area teacher is needed if the latter is to be achieved.
- (3) **Opinion Reports.** Opinion reports usually start with lessons requiring critical thinking and reading skills. Until critical thinking and reading skills are developed, students often parrot biases and prejudices without understanding different premises and viewpoints.

### 3. Steps Involved

- (1) **Selecting a Topic.** The student usually is free to select his report topic as long as it relates to the subject. Four things must be considered by the student when selecting a topic: (1) the topic should be of interest to the class, (2) it should be of interest to him, (3) there should be ample information available, and (4) it should not be too broad in scope.

A topic can be chosen in either of two ways. A list of topics meeting the above requirements can be presented to the student or he can get topic ideas through skimming indexes.

- (2) **Deciding What to Tell About the Topic.** Students need to read extensively about their subject, and then select main ideas. Through a process of elimination only those details most relevant to the topic should be included.
- (3) **Sequential Order.** Topic reports should be written and presented in sequential order. Reports are confusing if they do not keep to the subject and do not tell enough about the topic to make it interesting. The main points in reports should be kept in correct order.
- (4) **Gathering Information on the Subject.** The sources for obtaining information depend upon the topic, length, type and complexity of the report. Usually this means library research. Textbooks may also list sources or bibliographies telling where additional information may be obtained. Other sources the student may utilize are field trips, films, filmstrips, resource people and television programs.
- (5) **Organizing Notes Into Paragraphs.** After notes are taken and a tentative outline



is acquired, the report can be written. The main ideas and additional information for supportive details can be inserted.

The following example shows three main points or paragraphs. This gives an outline for an oral or written report:

I. History of Skiing

A. Means of travel

1. Dates back to early Scandinavia
2. Before the Christian era

B. As a sport

1. Began in Norway
2. Middle of 19th century

II. Skis

A. Made of solid wood

1. Ash
2. White pine
3. Hickory

B. Length

1. Fitted to the height of rider
2. Checking the right length
  - a. Extend arms above head
  - b. Upright skis extend to tips of fingers
3. A longer length often desirable

III. Ski Poles

A. Skier carries two wooden sticks

1. Pointed end
2. Metal disc

B. Uses

1. To get started
2. To balance himself
3. To alter his course

A written report using the same number notes would be as follows:

*The history of skiing as a means of travel dates back to early Scandinavia before the Christian era. Skiing is a sport begun in Norway in the middle of the 19th century.*

*A ski is made of solid wood, usually ash, white pine or hickory. The length of the ski should be fitted to the height of the rider. To see if a ski is the right length, the rider stands with his arms stretched at their full length above his head. The ski, standing upright, should reach at least to the ends of his fingers. A longer length is often desirable.*

*A skier carries two strong wooden sticks called ski poles. A ski pole has a pointed end with a metal disc on it. The rider uses the poles to get started, balance himself and steer his course.*

This first draft of the written report should be gone over once for correction, then put aside for a few days before reviewing it again.

- (6) **Revising the Report.** When revising the report the following questions should be considered: Does the outline make sense? Is the topic covered properly? Additions or deletions may take place during the revision. Different organization patterns may also be called for. After the report is written, the student needs to proofread for mechanics such as spelling, sentence structure, punctuation, paraphrasing of words, usage and grammar.
- (7) **Making a Bibliography.** Students should understand the requirements for each particular report in regard to the bibliography. The purpose of a bibliography is primarily for providing sources for obtaining additional information about the topic.

- C. **TAKING TESTS.** Evaluation of a student's performance in school is usually measured by standardized and informal tests. Many students do poorly on tests because of poor reading skills. Many do not follow test directions or understand the organization of the test. Students need instruction on specific techniques of studying for and taking an examination. For students with severe reading problems, taping the test or giving the test orally might be advisable.

There are two types of tests administered in the post-elementary school. They are either (1) subjective (essay) or (2) objective. Many students have limited experience with the essay test. Both types of tests measure main ideas and supportive details, but the organization differs in each. Teachers can provide a checklist to aid students in developing study techniques.

The following is an example of a checklist to be given to students:

- What type of test is to be given?
- Try to predict questions that will be asked. The teacher and class could use one unit and compare the questions which each thought to be the most important. This type of practice is needed for an adequate understanding of predicting questions and of main ideas.
- Try to recall main ideas and supportive details contained in the chapter.
- Review notes from lectures and the textbook emphasizing main ideas and supportive details.
- Review with another student. Each one should take a turn at answering questions.
- This can be helpful in that one student may think of a question that the other did not anticipate.
- Review the study guide, if one was used in the unit.

There are some specific points to teach students in order to prepare them for taking tests. The teacher should thoroughly explain the organization of the test. The student needs an understanding of the test so that his score is a true indication of his knowledge and not a reflection of his lack of comprehending the test organization. The following list will aid the teacher in helping students take tests:

- The teacher should instruct the students to read the directions carefully. They should ask if they do not understand and if they need help in interpreting the organization.
- The student should understand the scoring rules. Items worth more points than others should be given special emphasis. The student should be informed when there are penalty rules for guessing on objective tests.
- The student should be told to answer any questions when reasonably sure of the answer.
- The student should not spend too much time on questions that he is not reasonably sure of. In answering other questions the student may recall the answer to one previously skipped. In the time left over the test should be reviewed and any unanswered questions completed.

1. **Essay Tests.** Essay examinations may vary in scope from short answer questions to problem-solving questions. The main thrust of the essay test is that it requires the student to organize his thoughts. This means students should spend more time organizing before starting to write the essay. Planning, understanding key words and budgeting time are very important factors in essay tests.

The following key words appear frequently in the directions of essay examinations. An understanding of these words will enable the student to better express his knowledge. The list includes a brief definition of each word as used in essay examinations. The list is representative and not comprehensive either in depth of meaning or in number.

- *Compare* – state the similarities between the two things or ideas being compared.
- *Contrast* – state the dissimilarities between the two things or ideas being contrasted.
- *Criticize* – state your judgment about the merits or the truthfulness of the question.
- *Define* – state the meaning of a word or phrase in a concise manner.
- *Describe* – state the qualities or characteristics of the thing or idea.
- *Discuss* – state the pros and cons regarding the thing or idea. This includes all main points and supportive details.
- *Enumerate* – list or outline the points of the thing or idea.

- *Evaluate* – state your opinion or judgment of advantages or disadvantages of a thing or idea. Opinions or judgments from other resources may be included.
- *Explain* – analyze and interpret an idea or thing.
- *Prove* – giving facts or reasons to support a truism.
- *Review* – examine critically a thing or idea and then discuss it.
- *State* – present the main points or important supportive details presented in a concise manner.

2. **Objective Tests.** There are a variety of objective tests given by the content teachers. These include true-false, matching, completion and multiple choice. The objective test requires the student to recognize correct responses and completion tests, to recall words. The content area teacher can aid the student in taking objective tests by giving the following directions:

#### *Multiple Choice Questions*

- Read each item correctly in order to do what is requested.
- Be sure to read all the answers carefully and select the answer.
- Answer all the questions that you are reasonably sure of first, and then go back to the difficult ones.
- Pick out key words which include qualifying words.

#### *True-False*

- Answer all items you are reasonably sure of first, and then go back to the difficult ones.
- If the statement is marked true then the entire statement must be true. This includes statements with two clauses.
- Look for key words which include qualifying words.

#### *Completion*

- Answer all items you are reasonably sure of first, and then go back to the difficult ones.
- Usually the answer is a specific word or phrase.
- Answer the question with an answer that you think makes sense even if it is not specific. You may get partial credit.
- Look for key words.

#### *Matching*

- Mark the answers you are reasonably sure of first, then go back to the difficult ones.
- Mark off the ones used, if you are not allowed to use them twice.
- Read all the answers since two may seem correct, but only one can be chosen.
- Through the process of elimination, answer the remaining questions.

The following qualifying words that students should notice on objective tests are: all, always, sometime, never, none, only, usually, most, some, much, little, no less, greater, equal, smaller, good and bad.

D. **TEN WAYS TO STUDY THAT WORK.** Study habits are an excellent topic for class

discussion. Many content area teachers have study tips or study habits that have been successful in academic work, and many times handout sheets concerning study tips lead to a self-evaluation by students of their own study procedures. A handout sheet is included in this section to review study techniques:

1. **Make and Keep a Study Schedule.** Set aside certain hours each day for homework. Keep the same schedule faithfully from day to day. The amount of time needed for study will vary with the individual student and the courses on his schedule. An hour and a half to two hours each day is suggested for the average high school student.
2. **Study in a Suitable Place the Same Place Each Day.** Is concentration one of your study problems? Experts tell us that right surroundings will help you greatly in concentrating. Your study desk or table should be a quiet place — as free from noise as possible. You will concentrate better if you study in the same place every day.
3. **Collect All the Materials You Need Before You Begin.** Your study desk or table should have certain standard equipment such as paper, pen, ink, eraser and dictionary. For certain assignments you'll need a ruler, paste, a compass and a pair of scissors. With all your materials at hand, you can study without distractions or interruption.
4. **Don't Wait for Inspiration to Strike — It Probably Won't.** We can learn a lesson about studying from observing an athlete. Can you imagine seeing an athlete who is training for a mile run sitting on the field waiting for inspiration to strike? He trains strenuously every day whether he wants to or not. Like the athlete we get in training for our tests and examinations by doing the things we're expected to do over a long period of time.
5. **A Well-Kept Notebook Can Help Raise Your Grades.** Guidance counselors tell us that there's a definite relationship between the orderliness of a student's notebook and the grades he makes. Set aside a special section for each of the subjects on your schedule. When your teachers announce important tests and examinations, you'll find how priceless orderly notes can be.
6. **Make a Careful Record of Your Assignments.** Why lose time phoning all over town to find someone who knows the assignment? Put it down in your notebook in a special place. Knowing just what you are expected to do and when you are expected to do it is the first long step toward completing important assignments successfully.
7. **Use Trade Secrets for Successful Study.** Flash cards are "magic helpers." On the front of a small card you write an important term in history, biology or English, and on the back, a definition or an important fact about that term. Carry your flash cards with you. At odd times take them out and ask yourself the meaning of the terms. If you don't know, turn to the other side and review the answer. The "divided page" is another trick of the study trade. Make a dividing line down the center of a sheet of notebook paper. Then write important questions on the left side and the answers on the right. Use the "self-recitation" method of study. Cover the right-hand side and try to give the answer. Then check and recheck until you're sure you know the material.
8. **Good Notes Are Your Insurance Against Forgetting.** Learn to take notes efficiently as your teachers stress important points in class and as you study your assignments. Good notes are a must for just-before-test reviewing. Without notes, you will often need to reread the whole assignment before a test. With them, you can recall main points in just a fraction of time, making the time you spend in taking notes not time lost but time saved.

9. **Perhaps You've Asked, "How Can I Remember What I've Studied?" One Secret of Remembering Is Over-Learning.** Psychologists tell us that the secret of learning for the future is over-learning. Over-learning is continuing your study after you have learned the material well enough just barely to recall it. Experts suggest that after you say, "I have learned the material," you should spend in extra study one-fourth of the original study time. In an experimental study, students who over-learned the material remembered the material four times as much after 28 days had passed.

10. **Frequent Reviews Will Pay You Well in Knowledge, Grades and Credits.** Without review the average student can forget 80 per cent of what he has read in just two weeks. Your first review should come shortly after you study the material the first time. This early review acts as a check on forgetting and helps you remember far longer. Frequent reviews throughout the course can pay you well in pretest peace of mind.

11. **Add Willpower to Follow Through With Your Studies.** Suggestions about how to study help us no further than we help ourselves. As with most everything in our lives, the slogan is, "It's up to you." If you try earnestly to increase your study efficiency, the improved skills should become your permanent habit. The result can be a definite improvement in your performance at school and the satisfaction that comes from making the school year one of your very best. *Remember*, the habit of study takes the work out of study.

## SELECTED REFERENCES

- Adams, W. Royce. *How to Read the Sciences*. Glenview, Ill.: Scott, Foresman and Co., 1970.
- Aukerman, Robert C. *Reading in the Secondary School Classroom*. New York: McGraw-Hill Book Co., 1972.
- Burron, Arnold and Claybough, Amos. *Using Reading to Teach Subject Matter*. Columbus, Ohio: Charles E. Merrill Publishing Co., 1974.
- Duffy, Gerald G. and Sherman, George B. *Systematic Reading Instruction*. New York: Harper and Row, Inc., 1972.
- Morgan, Clifford G. and Deese, James. *How to Study*. New York: McGraw-Hill Book Co., 1969.
- Robinson, Francis P. *Effective Study*. New York: Harper and Row, Inc., 1961.
- Shepherd, David L. *Comprehensive High School Reading Methods*. Columbus, Ohio: Charles E. Merrill Publishing Co., 1973.
- Smith, Nila Banton. *Reading Instruction for Today's Children*. Englewood Cliffs, New Jersey: Prentice-Hall, 1963.
- Thomas, Ellen Lamar and Robinson, H. Alan. *Improving Reading in Every Class*. Boston: Allyn and Bacon, Inc., 1972.

# 8 Teacher Preparation

To be a successful reader in the English content area, a student must have mastered the following language skills:

- Setting purposes for reading, anticipating ideas, predicting outcomes.
- Reading to accomplish set purposes.
- Adjusting rate to purposes.
- Locating information effectively by using author's aids, such as tables of contents, indexes, subheadings, etc.
- Surveying, skimming, scanning, studying, reading critically.
- Comprehending main ideas and supporting details of reading passages, which subsumes detecting expository patterns (time, order, listing, cause and effect, comparison and contrast, etc.)
- Distinguishing between fact and opinion, between fact and fiction, recognizing propaganda, assessing objectivity of author.
- Making inferences.
- Applying concepts in other contexts.
- Forming generalizations and drawing conclusions.
- Following directions.
- Formulating questions.
- Interpreting graphs, charts, tables, maps, figures, etc.
- Extending knowledge of the technical vocabulary of the content area.

- A. **UNIT CONSTRUCTION.** Good teaching generally requires the teacher to plan in advance, with a statement drawn up for objectives, possible learning activities, instructional materials and evaluation techniques. After completing this, the teacher may then ask pupils to share in choosing specific activities and in planning details for working out the activities.

The objectives, the subject matter to be learned, the activities to be undertaken, the instructional materials and the evaluation procedures are considered in relation to each other in unit planning. In this, they are functional applications of curriculum theory. A unit is organized around some topic of significance. Facts, skills, generalizations and attitudes are brought together to form an entity. A unit has the following features:

1. Title or topic, age or grade level and time required.
2. Introductory statement which states general purposes and clarifies topics.
3. Objectives: Major understandings to be acquired by the pupils, main skills to be learned by the pupils and attitudes to be acquired by the pupils (some teachers may prefer to use interests, appreciations or aesthetic responses, instead of attitudes).
4. Content guide (this is especially useful in the intermediate grades; it may not be necessary in the lower grades).



Major subject-matter content.  
Problem to be solved.  
Projects to be undertaken.

5. Pupil activities required to achieve the objectives:

Initiatory activities.

- Activities required for the pupils to make a good start, including such interest-arousing elements as instructional materials, resource persons, excursions and films.
- Estimated time required for these activities.

Developmental activities.

- Activities required for the pupils to acquire facts, skills and attitudes. These activities are listed in the order in which they will facilitate learning most efficiently.
- Estimated time required for these activities.

Culminating activities.

- Summary activity or group of activities to which each pupil can contribute and toward which the class will direct its effort throughout the unit. This activity will best satisfy each pupil's need for approval from classmates and teacher and will promote favorable attitudes toward classmates, teacher and school.
- Estimated time required for these activities.

6. Materials and resources.

Printed materials, audiovisual aids and materials for demonstration, experimentation or display needed to make the learning activities interesting and worthwhile.  
Facilities outside the classroom that may be used.  
Procedures for bringing people from the community to the classroom and for taking the pupils on visits to the community.

7. Evaluation procedures.

Procedures to determine where pupils are when they begin the unit.  
Procedures to help pupils measure their own progress.  
Procedures to evaluate pupil improvement in understandings, skills and attitudes.

Not only a unit topic but also the teaching-learning activities within the unit should be selected, examined and modified in terms of the characteristics of a good organizing center. The entire framework must of course be adapted to the particular teacher's purposes by varying the emphasis given to different parts. It is also advisable, when the teacher is working with an already planned teaching unit, to make changes in estimated time, proposed activities, use of materials and evaluation procedures whenever a better learning situation can thus be provided.

**B. QUESTIONING TECHNIQUES.** Every teacher spends a great deal of time asking students questions, but all questions are not of equal value in stimulating active thought and discussion. To discover your questioning patterns, use one of the following two methods:

1. **Method One.** On a worksheet have a trusted observer tally every question you ask in

a specified period of time (15 minutes as a minimum) according to the following categories:

**Class 1:** Questions to which students can respond with a "Yes" or "No" answer. Example: Was George Washington the first President of the United States?

**Class 2:** Questions which students can answer with a simple, short, factual answer. Example: Who was the first President of the United States?

**Class 3:** Questions which require students to do some immediate thinking to find a correct answer (there is a correct answer). Example: What are the subject and object in the preceding sentence? What is the sum of 20, 89 and 34?

**Class 4:** Questions which require that students look for relationships and underlying concepts. Example: What similarities do you find between the causes of the First and Second World Wars?

**Class 5:** Questions which ask students for personal opinions and responses. Example: What do you consider to be more worthy of your concern: earth ecology or space exploration? In each column, the observer can simply classify every question you ask according to the five categories.

**2. Method Two.** Have an observer record verbatim every question you ask. After the lesson, read the questions very carefully and classify them according to the five categories on the worksheet.

After the tally is complete, discuss with the observer what the tally means to you. What kind of questions do you ask most often? What effect do these questions have on class discussions? Are you satisfied with the questions you ask? What, specifically, can you do to improve your questioning style? Make a contract with yourself about something concrete you will do to improve your questioning technique.

**3. Taxonomy of Questions.** All thinking can be classified into seven areas: memory, translation, interpretation, application, analysis, synthesis and evaluation. The categories of questions fit all subjects. Every question category has easy questions appropriate for young students or slow learners. Every category also has other questions that are challenging enough for bright students. The definitions of the seven kinds of questions overlap so that experts often differ on the best classification of certain questions. This need not bother classroom teachers. However, by knowing the definitions of the kinds of questions, a teacher can make certain that students practice in all types of thinking. Basically, the word "question" refers to any intellectual exercise calling for a response, including both problems and projects.

**4. Teachers' Questions and Children's Reading.** The following are categories of questions discussed in an excellent book on this subject by Norris Sanders. This book, *Classroom Questions: What Kinds?* (New York: Harper and Row Publishers, Inc., 1966) presents its subject in much greater detail than we can here. It is very profitable reading for any teacher attempting to improve his interaction with pupils, particularly when teaching in the content fields.

- (1) **Memory** — recognizing or recalling information as given in the passage. Sanders distinguishes four kinds of ideas on the memory level of thinking:

- Facts: Who did \_\_\_\_\_? When did \_\_\_\_\_? How many \_\_\_\_\_? What are \_\_\_\_\_?
  - Definitions of terms used in the test: What is meant by \_\_\_\_\_? What does \_\_\_\_\_ mean? What meaning did you understand for \_\_\_\_\_? Define \_\_\_\_\_ . Explain what we mean by \_\_\_\_\_ .
  - Generalizations – recognizing common characteristics of a group of ideas or things. What events led to \_\_\_\_\_? In what three ways do \_\_\_\_\_ resemble \_\_\_\_\_? How did \_\_\_\_\_ and \_\_\_\_\_ effect (cause) \_\_\_\_\_?
  - Values – a judgment of quality. What is said about \_\_\_\_\_? Do you agree? What kind of a boy was \_\_\_\_\_?
  - What did \_\_\_\_\_ do that you wouldn't?
- (2) Translations – expressing ideas in different form or language. Tell me in your own words how \_\_\_\_\_ . What kind of drawing would you make to illustrate \_\_\_\_\_? How could we restate \_\_\_\_\_? Could we make up a play to tell this story? How? What does the writer mean by the phrase \_\_\_\_\_? Write a story pretending you are \_\_\_\_\_ .
- (3) Interpretation – trying to see relationships among facts, generalizations and values. Sanders recognizes several types of interpretation:
- Cooperative – ideas the same, different, related or opposed. How is \_\_\_\_\_ like \_\_\_\_\_? Is \_\_\_\_\_ the same as \_\_\_\_\_? Why not? Which three \_\_\_\_\_ are most alike in \_\_\_\_\_? Compare \_\_\_\_\_ with \_\_\_\_\_ in \_\_\_\_\_ . How does \_\_\_\_\_ today resemble \_\_\_\_\_ in \_\_\_\_\_?
  - Implications – arriving at an idea which depends upon evidence in the reading passage. What will \_\_\_\_\_ and \_\_\_\_\_ lead to? What justification for \_\_\_\_\_ does the author give? If \_\_\_\_\_ continues to \_\_\_\_\_ what is likely to happen?
  - Inductive thinking – applying a generalization to a group of observed facts. What facts in the story tend to support the idea that \_\_\_\_\_? What is the author trying to tell you by \_\_\_\_\_? What does the behavior of \_\_\_\_\_ tell you about him? What events led to \_\_\_\_\_? Why? \_\_\_\_\_
  - Quantitative – using a number of facts to reach a conclusion. How much has \_\_\_\_\_ increased? What conclusions can you draw from the table (graph) on page \_\_\_\_\_? How many times did \_\_\_\_\_ do \_\_\_\_\_? Then what happened? How many causes of \_\_\_\_\_ can you list?
  - Cause and Effect – recognizing the events leading to a happening. Why did the boy \_\_\_\_\_? How did the boy make \_\_\_\_\_ happen? What two things led up to \_\_\_\_\_? When the girl \_\_\_\_\_, what had to happen? Why did \_\_\_\_\_ happen?

- (4) Application – solving a problem that requires the use of generalizations, facts, values and other appropriate types of thinking. For example, how can we show that we need a traffic policeman at the crossing at the south end of our school? If we want to raise hamsters in our classroom, what sort of plans will we have to make? John has been ill for several days. What could we do to help him during his illness? To show him we think of him?
- (5) Analysis – recognizing and applying rules of logic to solution of a problem. For example, discuss the statement: All teachers are kind and friendly. Some people think that boys can run faster than girls. What do you think? John was once bitten by a dog. Now John dislikes dogs. Is he right or wrong in his feelings? Why?
- (6) Synthesis – using original, creative thinking to solve a problem. For example, what other titles could you think of for this story? What other ending can you think for this story? If John had not \_\_\_\_\_, what might have happened? Pretend you are a manufacturer of pencils who wishes to produce a much better pencil. Tell what you might do.
- (7) Evaluation – making judgments based on clearly defined standards. For example, did you enjoy the story of \_\_\_\_\_? For what reasons? What do you think of \_\_\_\_\_ in this story? Do you approve of his actions? In the textbook, the author tells us that \_\_\_\_\_ felt \_\_\_\_\_. Is this a fact or the author's opinion? How do you know? This story has a very happy ending. Should all stories end happily? Why not? The author of our textbook apparently believes that the American colonists were right in their actions. Do you agree? What do you suppose the British said about the colonists? Write a short story about your favorite person in history. Tell why this person is your favorite.

C. **TEACHER SELF-EVALUATION CHECKLIST.** Individualization of instruction is a concept that most teachers are familiar with and use frequently in their classrooms. The following is a checklist that teachers should review before and during an individualized program to assure its success.

1. Have I examined the reading records in the record card folder?
2. Have I examined the IQ, reading and other pertinent test data on the test record card?
3. Have I administered the informal textbook test?
4. Have I made written records of each pupil's strengths and weaknesses?
5. Do I have a 5" x 8" card or notebook section for each pupil?
6. Does each child have a reading envelope or reading notebook?
7. Have I established routines for taking and returning books?
8. Do I have a way of keeping track of public library or privately owned books that have been brought in by the pupils?
9. Have I established a routine for indicating when a book is being read?
10. Do I keep a systematic check and written record of the number and rotation of individual conferences?
11. Have I developed a vocabulary for children's comments about books?
12. Have I established a method for each child to keep a record of his word growth?
13. Do I have records to show which children have read a particular book?

14. Have I formed flexible groups based upon common needs?
15. Am I developing skills based upon individual, group and class needs?
16. Am I using workbook material selectively to eradicate individual, group and class weaknesses?
17. Am I using the reading to integrate the various language arts?
18. Have I developed a variety of pooling procedures for sharing books?
19. Am I guiding student reading in order to widen, elevate and refine tastes?
20. Am I seeking natural ways of integrating reading with other curriculum areas?
21. Does my room tastefully reflect a rich reading program? (charts, book displays, letters, paintings, stick puppets, etc.)
22. Does my plan book include ways of pooling for the week's vocabulary work, group work and names of students for whom conferences are planned?
23. Does my plan book make provision for specific reading skills that I plan to teach each week, and do I list sources that I will employ toward this end?
24. Have I made an index card for every book furnished by the school for the reading program?
25. Have I made a list of publishers and their addresses easily available for each child?

# 9 Assessment

English teachers know that English as a tool leads to English as a process for fully enjoying, appreciating and using language. Bringing students and words together places a responsibility on the English teacher to assess the strengths and weaknesses which will enable or hinder students in their learning. The following examples are means of assessing the reading levels of students and the readability of materials for those students.

- A. **DIAGNOSTIC SURVEY.** Directions for the diagnostic survey test are based on an English literature textbook.
- I. Use between 30-40 questions.
  - II. Use questions designed to measure the following reading skills in the proportions shown below.
    - A. Using parts of the book (3 questions in all)
      1. Table of contents
      2. Index of titles
      3. Glossary
      4. Biographical data
      5. Introductory paragraph to story
    - B. Vocabulary needs
      1. Meaning (7-8 questions)
        - a. General background of word meanings
          - (1) select correct meaning from several dictionary meanings
          - (2) antonyms, synonyms
        - b. Contextual meanings
      2. Word recognition and attack (14-15 questions)
        - a. Divide words into syllables
        - b. Designate the accented syllable
        - c. Note and give meaning of prefixes and suffixes
        - d. Change the part of speech of a word (noun to verb, adjective to adverb, etc.)
    - C. Comprehension (11-12 questions)
      1. Noting the main idea
      2. Recalling pertinent supporting details
      3. Drawing conclusions, inferences
      4. Noting the sequence of ideas
    - D. Reading rate. Have student note the time it takes for him to read the selection. Then figure reading speed in words per minute.
    - E. Skimming to locate information (2-5 questions). Use selection different from the one used for comprehension speed purposes.

- III. Choose a reading selection of not more than four pages.
- IV. Administering the inventory
- A. Explain the purpose of the inventory and the reading skills it is designed to measure. When the inventory is given, advise the students which skill is being measured.
  - B. Read each question twice.
  - C. Questions on the use of the parts of a book are asked first. Students will use their books.
  - D. Introduce the reading selection, establishing necessary background on the topic and giving the students a question to guide their reading.
  - E. Read selection silently. Note and figure speed.
  - F. Ask questions on vocabulary. Students will use book for questions measuring ability to determine meaning from context. They will not use the book for other vocabulary questions, and these should be written on the blackboard.
  - G. Skimming. Use a new selection. Books will be used.
- V. A student is considered to be deficient in any one specific skill if he answers more than one out of three questions incorrectly when there are more than three questions measuring a specific skill.
- VI. This inventory, being administered to a group, does not establish a grade level. Nonetheless, anyone scoring above 90 per cent may be considered to be reading material too easy for him. Anyone scoring below 65 per cent may be considered to be reading material too difficult for him. If the material is suitable, the scores should range between 70-90 per cent.
- VII. Tabulate the results on a class profile chart.
- VIII. Sample form of inventory
- A. Parts of book
    1. On what page does the unit (selection) entitled *Exploring One World* begin?
    2. What section of your book would you use to find out something about the author of a story in the book?
    3. In what part of the book can you find the meaning of a word that you might not know?
  - B. Introduce story – explore student background of experiences on the subject of the story and set up purpose questions. Students read silently. Time required is noted.
  - C. Vocabulary – what is meant by the word “crab” as it used in the story (line \_\_\_\_\_, column \_\_\_\_\_, page \_\_\_\_\_)?

- D. Contextual meaning – what is meant by the word “eliminate” (line \_\_\_\_\_ , column \_\_\_\_\_ , page \_\_\_\_\_ )?
- E. Synonyms and antonyms
1. What word means the opposite of temporary?
  2. Use another word to describe the coach when he looked amazed.
- F. General knowledge of meaning
1. Select the proper meaning of the word “entice.”
    - a. To lure, persuade
    - b. To force
    - c. To ask
    - d. To caution
  2. Select the proper meaning of the word “initial.”
    - a. The last or end
    - b. The beginning or first
    - c. The middle
    - d. A letter of the alphabet
  3. Select the proper meaning of the word “rectify.”
    - a. To do wrong
    - b. To make right
    - c. To destroy
    - d. A priest’s home
- G. Word recognition of syllabication and accents – divide the following words into syllables and show which syllable is accented: eliminated, amazed, undemocratic and fraternities.
- H. Prefixes and suffixes
1. What does the prefix “un” mean as used in undemocratic?
  2. What is meant by “pre” in the word prescription?
  3. Change the verb “astonish” to a noun.
  4. Change the noun “boy” to an adjective.
  5. Change the adjective “democratic” to a noun.
  6. Change the adjective “slow” to an adverb.
- I. Comprehension of main ideas
1. What is a \_\_\_\_\_ ? What happened when \_\_\_\_\_ ?
  2. Such questions as applicable here; ask for only the main points of the story.
- J. Details – questions about specific bits of information concerning principal characters or ideas.
- K. Drawing conclusions and inferences – questions, the answers to which are not completely found in the textbook. Questions beginning with “what,” making comparisons or predicting what may happen, e.g., why did Bottle imagine he could perform such astounding athletic feats as setting the state high school record in jumping?
- L. Sequence – questions asking what happened as a result of \_\_\_\_\_ , e.g., what steps did the police use to solve the mystery?



K. Skimming – use a new reading selection and design questions to encourage the pupil to locate some specific bit of information.

B. **OUTLINE AND SUGGESTIONS FOR CASE STUDIES.** The following outline should serve as a guide for you in gathering information for a case study. When you compile the final case study report, you will want to include in it selected factors that have had an influence in causing student's disability. If possible, you should gather information in *each* of the major areas (designated by Roman numerals) so that you can consider all available information in making diagnosis. The questions under each major area are intended to be *suggestions*, however, and *do not* have to be followed as an outline. Some suggestions for remediation should accompany the case study diagnosis.

I. Educational Background

- What subjects or grades has the student failed?
- How many different schools has the student attended?
- Has the student been in schools or classes that were unusually crowded?
- At what age did the student begin school?
- Has the student's attendance been good?
- Does the student have a good relationship with the student's teachers and classmates?
- Does the student enjoy the the student's schoolwork?
- In what subjects has the student done well?
- In what subjects has the student had difficulty?
- What subjects does the student like and dislike?

II. Home Environment

- Has the student any brothers or sisters?
- Is there conflict or rivalry between the student and the student's brothers or sisters?
- Is a foreign language spoken in the home?
- Are reading materials available in the home?
- What are the interests and activities of the family?
- What is the attitude of the student's family toward the student's school work?
- Are they disinterested, anxious, ambitious?
- Is the home economically secure?
- Is there conflict in the home, either between father and mother or between parents and children?

III. Physical Conditions

- Has the student any obvious physical defects?
- Is the student apathetic, listless, fatigued?
- Is the student hyperactive, irritable, nervous?
- Is the student's posture poor?
- Has the student been ill frequently or had prolonged illnesses that might cause frequent absence from school?
- Is the student underweight or overweight?
- Are there any doctor's or dentist's reports to indicate the status of the student's health?
- Does the student have frequent colds or headaches?

Does the student have any speech defects?

#### IV. Emotional Condition

- Are there any reports from psychologists or counselors to indicate the status of the student's emotional health?
- Does the student have difficulty concentrating or persevering at a task? Why?
- Is the student's attention easily distracted? Why?
- Is the student defiant, boisterous, aggressive? Why?
- Is the student overly shy or quiet? Why?
- Does the student have nervous traits (nail-biting, restlessness, insomnia)? Why?
- Is the student involved in any truancy, frequent mischief, destructiveness, etc.? Why?
- Does the student daydream frequently? Why?
- Does the student act "lazy" or absent-minded? Why?

#### V. Social Characteristics

- Does the student have many friends? Are they older or younger than he?
- Does the student prefer solitary, isolated life or active, social contacts?
- What activities or interests does the student enjoy (movies, trips to the zoo, television, baseball)?
- Are the student's relations with the student's associates friendly, or are they marked by friction and conflicts?
- Has the student made a good adjustment to the opposite sex?

C. **IS THE STUDENT READING THE RIGHT BOOK?** It is important that a student in junior or senior high school perform on a level that assures the student a successful reading experience as a reward for the student's effort. A student will be reading the right book if consideration is given by the teacher to the student's four reading levels.

I. **Independent Level:** Can the student read this book on his own?

- Is this a book the student can take home to enjoy without help from a teacher or parents?
- Does the student read it without difficulty?
- Does the student have 90 per cent comprehension of vocabulary and concepts?
- Does the student pronounce 99 per cent of the words correctly?
- Is there an absence of head movement, vocalization and finger pointing?
- Is the student's phrasing good when reading aloud?

II. **Instructional Level:** Can the student read this book with some instruction?

- Is this a book that will help the student grow in reading?
- Is the student challenged by the material? Is it sufficiently difficult?
- Does the student have 70 per cent comprehension of vocabulary and concepts?
- Does the student pronounce 95 per cent of the words correctly?
- Is there an absence of head movement, vocalization and finger pointing?
- Is the student's phrasing fairly good when reading aloud?

III. **Capacity Level:** Does the student understand the book when it is read to the student?

- Is this a book the student could read if the student had the necessary skills?
- Is the student able to listen with comprehension?
- Does the student have 75 per cent comprehension of vocabulary and concepts?
- Can the student accurately pronounce the words the student hears?
- Can the student discuss or give a report or talk about what has been read to the student?
- Does the book give the student practice in the use of words to describe facts or experiences?

IV. Frustration Level: Does the student bog down on this book?

- Is this book better avoided for this reader?
- Does the student find the book too difficult?
- Does the student have 50 per cent or less comprehension of vocabulary and concepts?
- Does the student pronounce 90 per cent or less of the words correctly?
- Does the student exhibit head movement, vocalization, finger pointing, flushed face, tension or other signs of nervousness or embarrassment?
- Does the student show apparent lack of interest or poor attention?
- Does the student procrastinate about reading this book?
- Does the student think reading this book is futile for him?

Teacher's Notes:

American Education Publications grants permission to reproduce this page for classroom use.

# 10 Anticipation and Preparation

One of the aspects of reading which is necessary at all levels of reading development is called readiness. A discussion of this topic typically includes at the preschool level such concepts as letter names, sight words, left-to-right orientation and letter-sound relationships. At the middle and secondary school levels, readiness for reading includes such topics as motivation, setting purposes for reading, "being in the mood" for reading and developing a positive attitude for reading. Three techniques are suggested as activities which anticipate the act of reading: advanced organizers, structured overviews and purpose setting questions using directed reading-learning activities.

- A. **ADVANCED ORGANIZERS.** An individual's previous understandings and experiences are major factors in learning and retention of knowledge. Often called a cognitive structure, this background of knowledge is arranged according to highly generalized concepts, less inclusive concepts and specific facts (Ausubel, 1963, 1965). One way to anticipate the reading act is to predigest, abstract or provide a passage of 300-500 words in length which summarizes, clarifies organization or deals with the larger concepts of the reading passage. In a sense, the student has preread the passage for ideas and knows how many and what kind of ideas the passage will identify and explain. By means of the advanced organizer, the student has established a cognitive structure.
- B. **STRUCTURED OVERVIEWS.** Like the advanced organizer the structured overview builds on the idea of cognitive structure. In diagrammatic form the relationships of concepts, ideas and themes are presented in the vocabulary of the reading passage. Seeing a graphic representation of the relationships, prior discussion of the meanings of the vocabulary items and clarification of the reading relationships gives the students a firm base upon which they build the understandings of what they read.

The structured overview could just as easily be a follow-up or concluding summary of the reading or units of reading activities. It is intended to demonstrate relationships between important words and to relate new vocabulary to pertinent, familiar concepts.

### *Steps in Constructing and Using Structured Overviews*

Vocabulary	Diagram
Background concepts	Discussion

### *Interrelationships*

Students	Reading-learning task
Teachers (you)	New information

The following is compiled from notes of a lecture by Julie Johnstone of the Reading Center at the University of Virginia.

1. Analyze the vocabulary of the reading-learning task and list all the words that you feel are important for the students to understand. (This does not mean words you feel the students will not understand; in fact students should understand most of this vocabulary in order to understand the structured overview.)

2. Add to the diagram vocabulary concepts which you believe are already understood by the students in order to depict relationships between the reading-learning task and the discipline as a whole.

3. Evaluate the overview. Have you clearly depicted major relationships? Can the overview be simplified and still effectively communicate the ideas you consider to be crucial?

4. Introduce the students to the reading-learning task by displaying the diagram and explaining why you arranged the terms as you did. Encourage them to supply as much information as possible.

5. During the course of the reading-learning task, relate the new information to the structured overview as it seems appropriate.

The following examples of structured overviews are intended only as idea stimulators. These ideas are filled-in. Leave blanks where students might fill-in or where the teacher can supply information. Transparencies and overlays can be effective means of presenting the overview.

# SAMPLE STRUCTURED OVERVIEW

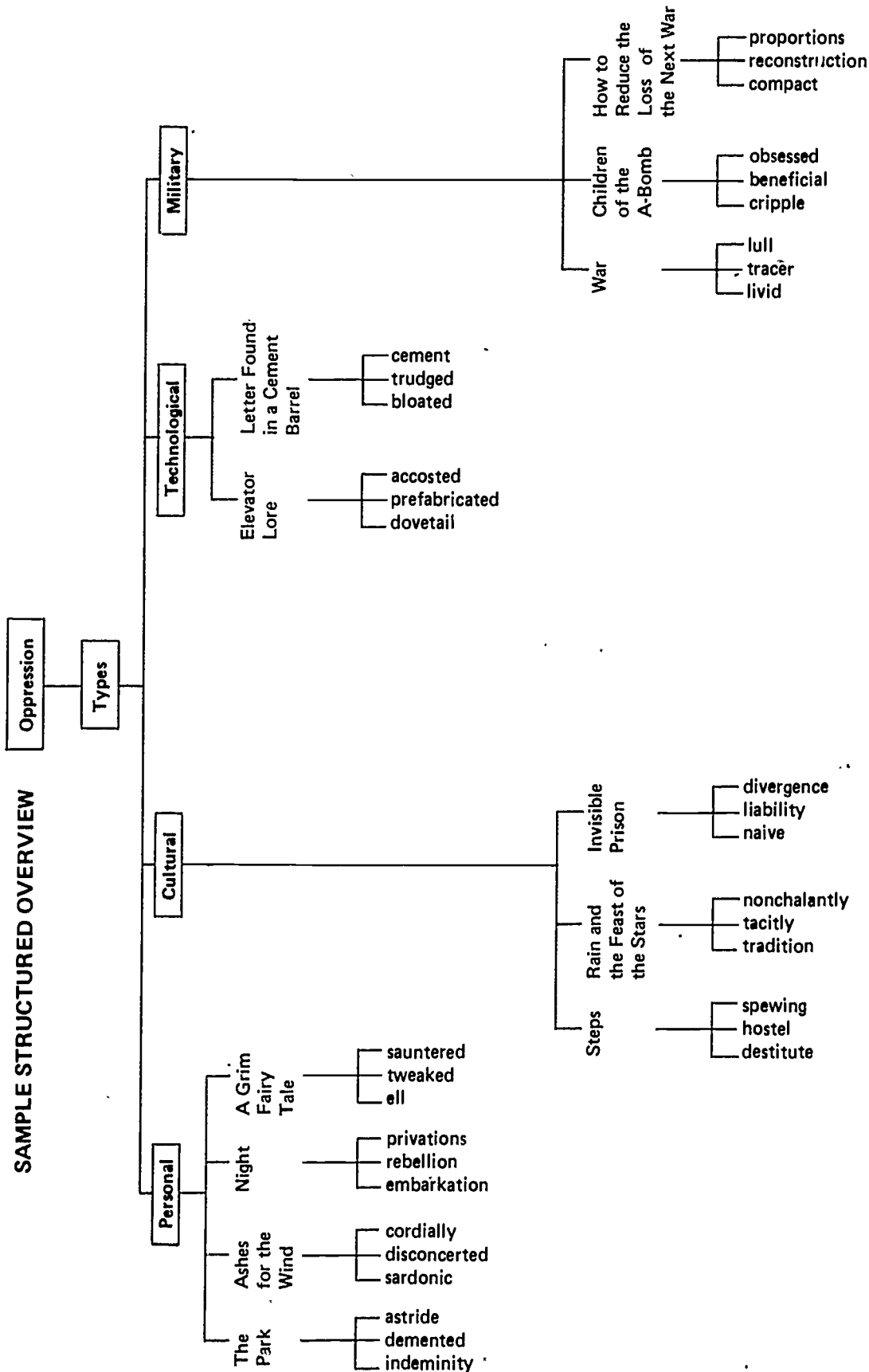

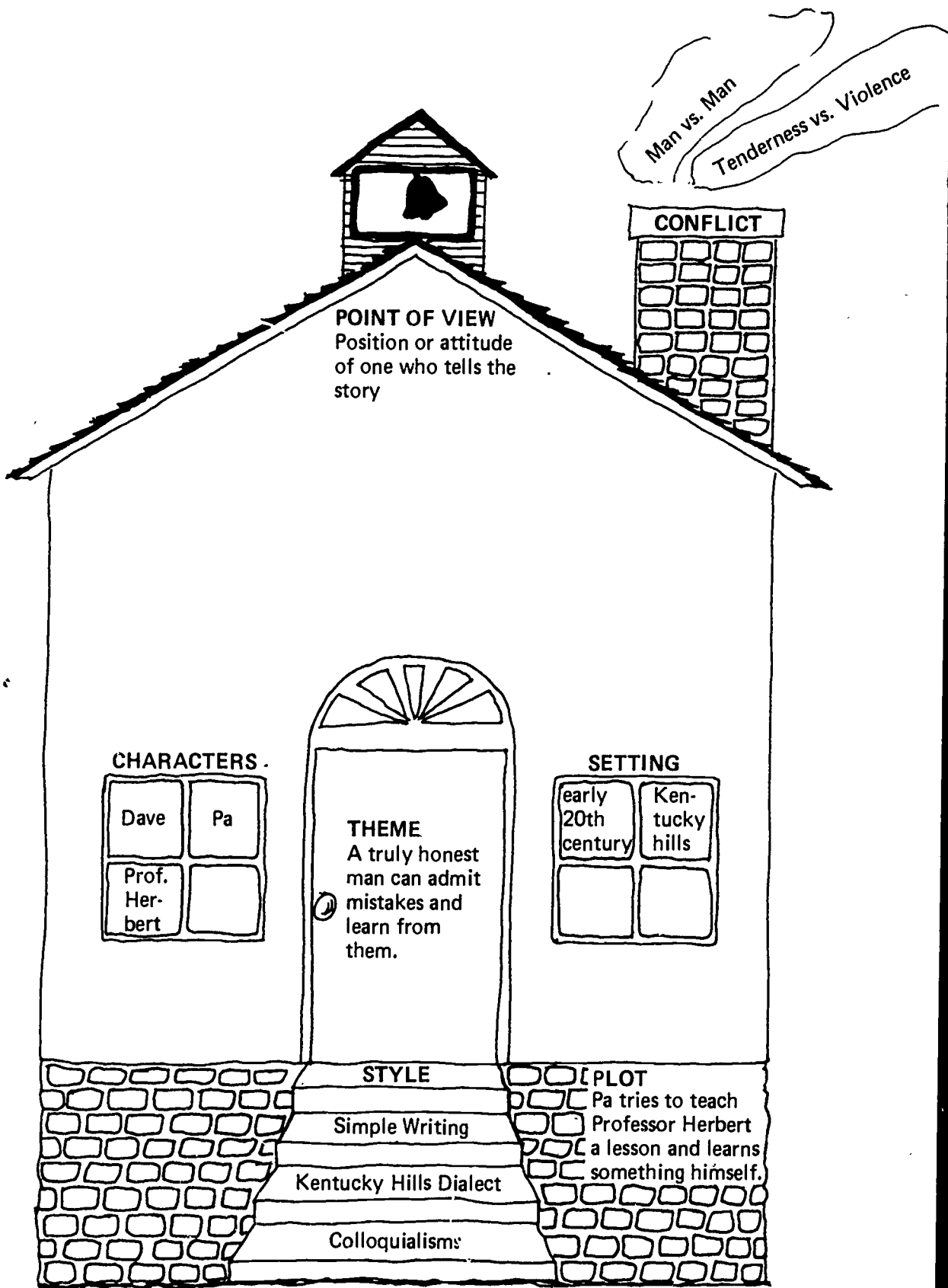

**SAMPLE STRUCTURED OVERVIEW  
FOR "SPLIT CHERRY TREE" BY JESSE STUART**

**SAMPLE STRUCTURED OVERVIEW  
FOR "SPLIT CHERRY TREE" BY JESSE STUART**

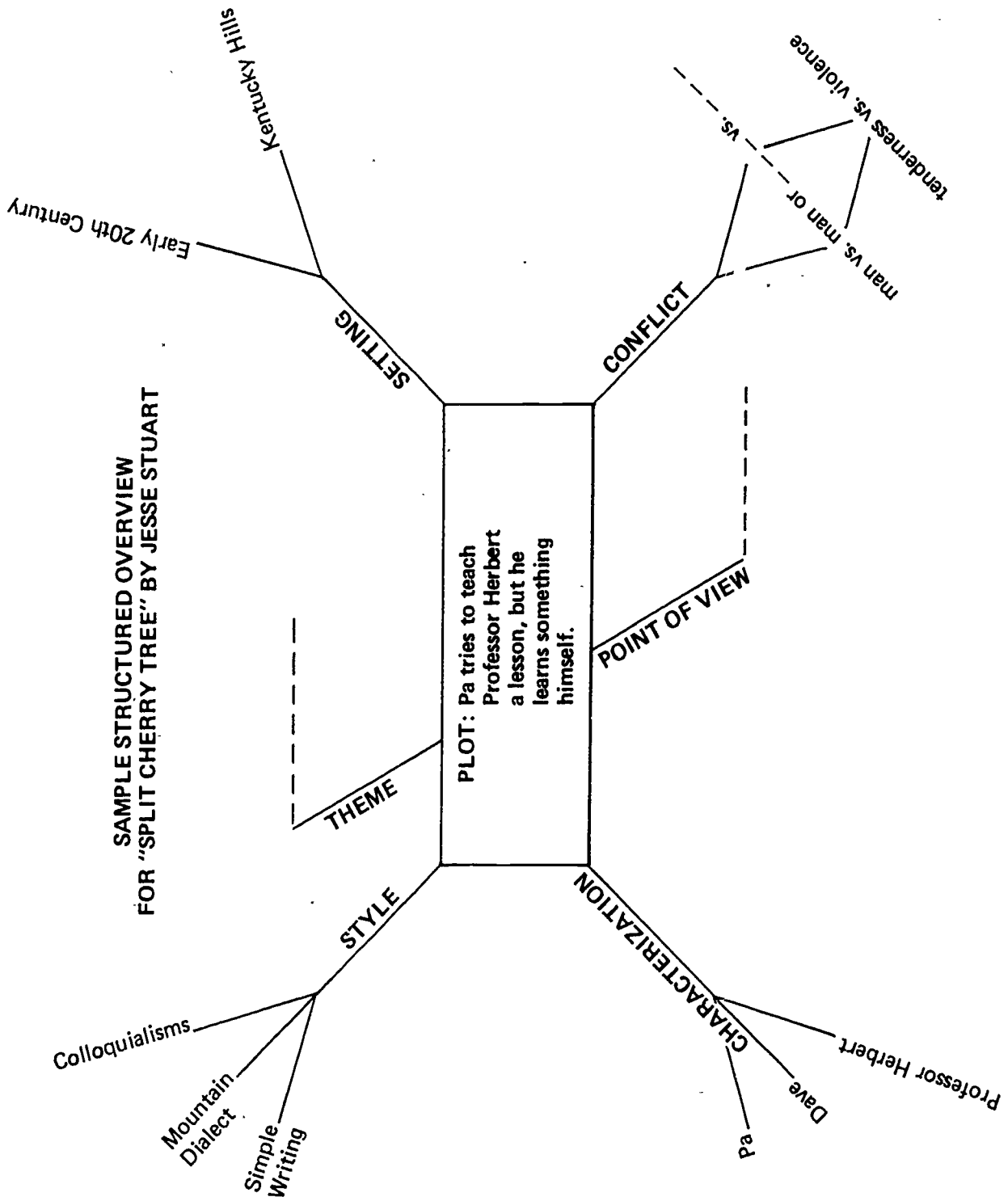



**SAMPLE STRUCTURED OVERVIEW  
FOR "THE SCARLET LETTER" BY NATHANIEL HAWTHORNE**

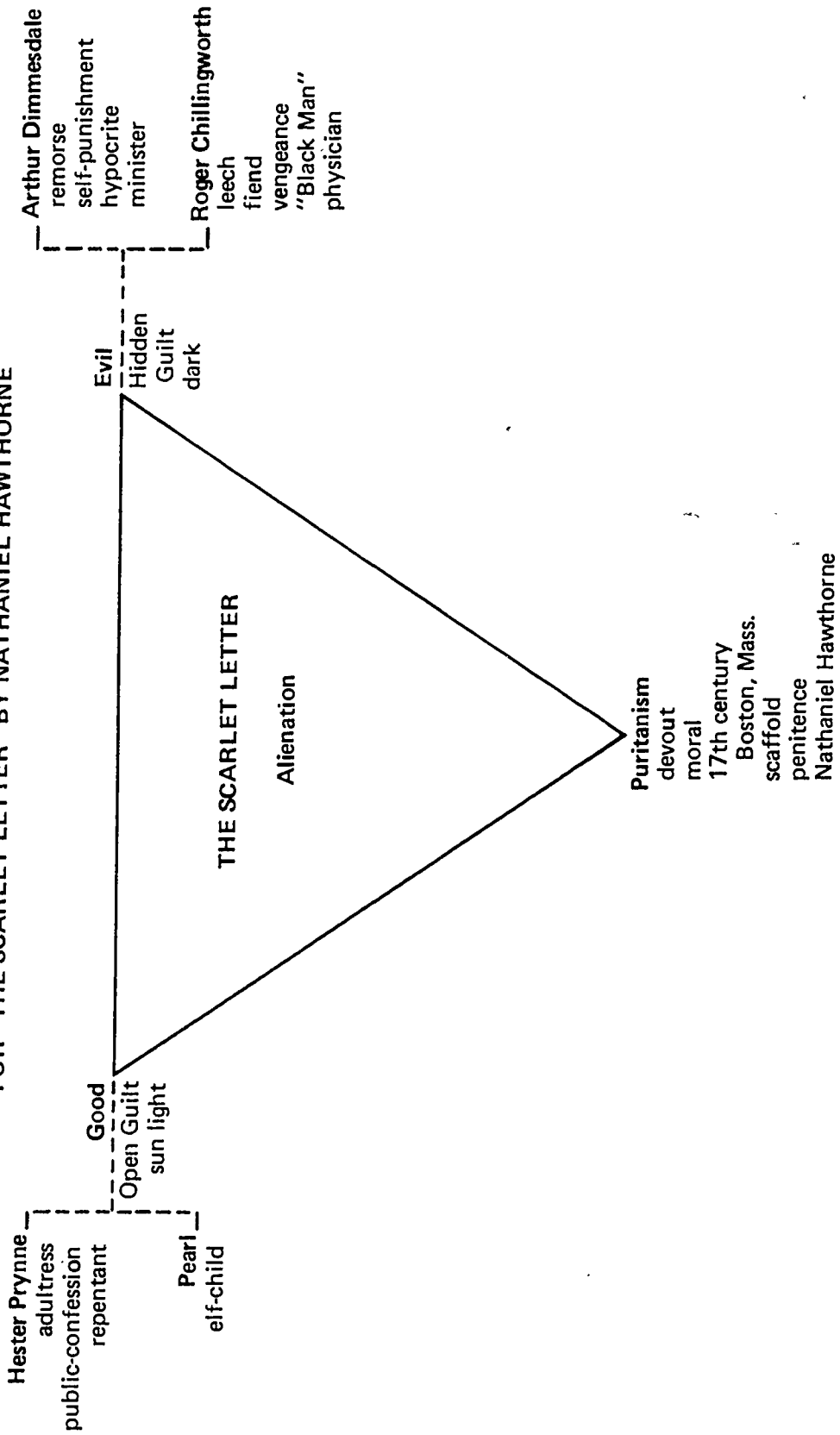

C. **GROUP DIRECTED READING-THINKING ACTIVITY: PREDICT, READ, PROVE SET PURPOSES, REASON AND TEST IDEAS.** A Group Directed Reading-Thinking Activity (DRTA) is a method of teaching a reading lesson used with a group of eight to twelve students who have the same fundamental skills, who read the same "fresh" material at the same time. The teacher directs the activity so that the students have a question to be answered or a doubt to be satisfied. The students read to satisfy the purposes *they* set individually. In doing so, they test and retest ideas, order and reorder purposes, reason and judge in an effort to answer their questions. The students report their findings to the group and prove them by reading the appropriate passages. There is a predict-read-prove cycle. The students employ word-attack skills in the context of their reading. The teacher, however, is always ready to aid with word recognition or comprehension. The members of the group are responsible to one another for proving predictions, offering one another suggestions or generally maintaining a self-respect for each member of the group. The specific strategy for this activity is as follows:

I. Identifying Purposes for Reading

- A. Introducing the Selection – Key Principle: no pretalk readiness on the part of the teacher. Instead, consider the title alone, the title and the pictures or the first paragraph or page.
- B. Key Question: "What do you think this story is going to be about? What do you think a story with a title like this may be about? What do you think might happen in this story?"
  - 1. The group at random predicts considering all the possibilities.
  - 2. "Of all these possibilities, which one do you choose?" In response to this question, individuals commit themselves. This commitment is important in the psychology of learning. The learner is now involved. He is a committed learner. Then he is interested in finding out if he is right or wrong. To do so, he must read! These self-declared purposes (1) avoid pitfalls of assigned purposes and the artificiality of ready-made questions and (2) make the reader a servant of what he is reading rather than of recitation.
- C. Thinking Involved in Predicting
  - 1. Divergent thinking – Early in the story, with little information, many conjectures are possible.
  - 2. Convergent thinking – Later, when more of the story has been read, predicting is limited.

II. Adjusting Rate to Purpose and Material

- A. Each student decides how much information he wants to get. He reads to find answers to his questions, not to learn everything on the page. Therefore, the reader must be clearly aware of his questions as he reads and adjust his rate accordingly. Each reader should be thoroughly acquainted with the attributes that distinguish one adjustment from another.
- B. Four Categories of Rate Adjustment
  - 1. Skimming – Relating swiftly and lightly for single points. Read to answer who, what, when and where questions, seldom how and why questions.
  - 2. Scanning – Reading carefully from point to point. Read to answer

questions such as, "How does X differ from Y?" The answer is found in different parts of the selection.

3. Critical reading – Reading and rereading, reflecting in order to pass judgment. Read to answer how and why questions. Comparisons are made, details noted and decisions made.
4. Surveying – Reading to get an overview of the selection. This rate is especially important for content material and for every individualized reading program. Read title, subtitles and preface; check about the author; look at pictures, etc.

### III. Read Silently to Satisfy Purposes

- A. As the students read, the teacher observes abilities to adjust rate, general attitudes toward the task and habits such as lip reading and finger pointing to the purposes and material. He also acknowledges requests for help with word recognition needs by providing *clues* for context, sound and sight.
- B. Before a student asks for help, the student should have gone through certain steps in attempting to recognize a word he did not know instantly: First, the reader reads to the end of the sentence in which the unrecognized word appears. He knows from experience that getting the idea proves to be effective. His attention is focused on comprehension. He looks for picture clues too. Second, he tries to sound the word and pronounce it. If he can pronounce it correctly, he may recognize the word as one in his speaking-meaning vocabulary. He then turns to the teacher for help. Here is the mark of a scholar since he has tried all the skills at hand, and he knows he doesn't know and must turn to someone more skilled.

### IV. Developing Comprehension

- A. Defending or Refuting Purposes
    1. Key questions: "Did *you* find the answer to your question? Were *you* right about what you thought would happen?"
    2. Oral reading to prove a point. "Read the line that proves it. Read the lines that gave you this idea." Students must be continually required to produce evidence from their material read to prove they were right or wrong or to give reasons why they should alter conjectures. (There is a difference between producing evidence and simply reproducing the sequential facts of a story.)
  - B. Redefining Purposes – Key Questions: "What do you think now? What do you think will happen next?" Reading is a continuous process. The reader must continuously adjust his thinking, redefine his purposes and adjust his rate. These four steps of a directed reading-thinking activity may be repeated several times during one directed reading-thinking activity.
- D. **INTEREST AND MOTIVATION.** Teachers must put forth a concentrated effort on building motivation to read. Frequently students are forced to read books that they have no initial interest in, and teachers neglect to stimulate interest with predicussions and fail to make the topic relevant to the student at his current phase of development. Furthermore many students have been turned off to reading because too many book

reports or writing assignments were required; they were forced into a close study situation; they were forced to plod through a dull book because it was considered a classic, or they had to read the whole book. It is recognized that there is often a conflict between what students want to read and what school systems think they should read. Thus it is the teacher's responsibility to guide, stimulate and broaden students' interests into acceptable channels. Following is a list of suggestions that might be found useful in creating student interest in various books.

1. Have a large selection of books that includes paperbacks, current releases and magazines. Allow students to make suggestions.
2. Though students should be allowed to choose freely, be available to offer assistance.
3. Motivate students through the use of:
  - (1) Displays (by a revolving book rack)
  - (2) Other media (radio, T.V., movies, newspaper)
  - (3) Book clubs
  - (4) Comfortable places to read
  - (5) Records of individual progress

# Manipulation

- A. **THINKING STRATEGIES.** Playing with words, ideas, feelings or facts gives the English student a sense of creative endeavor. It reinforces the words which are used to convey personal understandings or ideas. Manipulating the printed word, a privilege few other media provide, allows the reader to reflect, anticipate and read the last page or paragraph first or the first paragraph eight times. The reader structures what is read into broader, abstract concepts. Words and ideas are restructured into meaningful units depending on developed thought processes, past experiences, prejudices and other strongly held attitudes.

The teacher has the dual responsibility to develop the skills needed to efficiently read, understand and evaluate what is read in the light of the reader's own past experiences. Often called critical reading, the process is also critical thinking. The techniques of manipulation aid the reader to develop thinking strategies, vocabulary, spelling skills and personal confidence in defending choices of thinking or skill strategies.

Guiding students in knowing the difference between a literal level, an interpretive level or an applied level is necessary if one wants the student to judge the difference between fact, inference and projection. Moving a student's thinking from simply recalling what happened in a plot to identification of theme(s) and universal truth(s) is a desired outcome of reading and understanding what is read.

One method to call attention to these three levels of reading is the use of a 3-Level Study Guide developed by Thomas H. Estes at the University of Virginia in 1973. In order for the student to understand what is read, some response to the understandings should take place. The 3-Level Study Guide provides for a response at: Level 1, which is what the author said; Level 2, which is what the author meant, and Level 3, which is how the meanings can be used. The three steps in constructing a 3-Level Study Guide are as follows:

Step I. Analyze the Content of the Reading Selection. Ask yourself:

- A. What are the concepts and understandings which I want the students to derive?
- B. Why am I requiring this activity of the students?

List as many of these understandings as you can think of. You now have raw material from which you may draw Level 2 statements.

Step II. Re-examine the content under consideration. Identify and list the statements of fact which are basic to understanding the content identified in Step I. You now have raw material from which you may draw Level I statements.

As you complete Steps I and II, you will undoubtedly find that some of the understandings identified in Step I are not adequately supported by the details you were able to identify in Step II. On the other hand, understandings other than the ones you foresaw may appear possible once you examine the facts of the matter

more closely.

Rearrange and rework material from Levels 1 and 2 until you get a reasonable fit. It is these content analysis steps which will determine the success of the guide in helping you and your pupils reach your objectives.

Step III. As the last step, consider and list possible extensions of the material. Ask yourself:

- A. What are the most generalized conclusions which can be drawn from this content?
- B. What "universal" truths find support or example in this content?

List these possible applications of the material. These ideas will go into your Level 3 section of the guide.

It is a good idea to leave adequate space and to encourage pupils to make original, personal comments at this level.

1. **Cautions to Be Observed in the Use of Study Guides.** The following is compiled from notes of a lecture by Thomas H. Estes of the Reading Center at the University of Virginia.

- (1) Study guides should be used for those sections of the textbook with which students need extra help. Don't prepare guides for every day and every chapter.
- (2) Variety in guide format is encouraged. Don't let boredom with the procedure interfere with quality of the product.
- (3) Study guides should not be graded. They are *not* designed as tests and should not be used as such. They are study guides only. Elimination of grading removes the need for cheating or copying another's answers.
- (4) Study guides do not "run themselves." They are effective only when students know how to work in groups and how to apply techniques which have clearly been taught.
- (5) Study guides can be mere paper-shuffling and busy work if they do not meet specific skill and understanding needs of individual students.
- (6) Study guides are not a panacea. They are but *one* method of providing for individual needs and helping students grow toward independent learning. Furthermore they are but one part of a general lesson strategy calling for pre- and postreading activity as well as activity concurrent to reading.

2. **Examples of the 3-Level Study Guide.** The following 3-Level Study Guides are based on prose writing – a fairy tale and a short-story by Saki. The technique is transferable to other genre and other disciplines of study. Given sufficient practice students might use the device for note taking, class-group activities or just as an aid to their understanding of what they read. Teachers should help students identify major understandings of the reading prior to a student attempt at creating the study guide.

*Little Red Riding Hood*

Level 1 – What did the author say? Check two.

- a. Red Riding Hood met a wolf in the woods.
- b. Red Riding Hood visited her aunt.
- c. Red Riding Hood recognized the wolf immediately upon entering Grandma's house.
- d. The woodsman killed the wolf.

Level 2 – What did the author mean? Check two.

- a. The wolf only wanted the goodies meant for Grandma.
- b. The wolf appeared a lot like Red Riding Hood's grandmother.
- c. Red Riding Hood was a naive little girl.
- d. Red Riding Hood was a trusting little girl.

Level 3 – How can we use the meaning? Check two.

- a. Don't walk in the woods alone.
- b. Don't speak to strangers.
- c. Look more carefully at sick grandmothers.
- d. All's well that ends well.
- e. Don't send a little girl to do a nurse's job.

*The Open Window* by Saki (H. H. Munro)

Level 1 – What are the facts in the story? Check six.

- a. Vera is 12 years old.
- b. Framton Nuttel is a horse doctor.
- c. Mrs. Sappleton is Vera's aunt.
- d. Framton did not know any people in the town.
- e. One of the hunters wore a red coat.
- f. Ronnie was singing, "Bertie, Why Do You Bound?"
- g. The hunters always come in through the window after they hunt.
- h. Framton needs plenty of rest and relaxation.
- i. Vera spoke to Framton about the window.

Add any other facts that you wish.

Level 2 – What did the story mean? Check six.

- a. Framton Nuttel was a very smart man.
- b. Framton was trying to be polite.
- c. Vera liked to make up stories.
- d. Mrs. Sappleton was crazy.
- e. Framton did not like talking to strangers.
- f. Mrs. Sappleton did not know why Framton was nervous.
- g. Framton hated hunting.
- h. Mrs. Sappleton was heartbroken over the death of the hunters.

- i. Vera was a good story-teller and actress.
- j. Framton was a victim of his own credulity.

Add any other things you can think of that the story meant but did not specifically say.

Level 3 – How can we use these meanings? Check one.

- a. A person sees what she/he wants to see.
- b. People who live in the country are strange.
- c. Never believe anything a girl says.

Add at least one more interpretation.

**B. CONCEPT GUIDES: VARIATION ON THE 3-LEVEL GUIDE.** By the secondary years of schooling certain assumptions are made about students and reading. It is usually assumed that students can read. All too often the efficiency of the reading is questionable and the students don't seem to understand what they have read. This inability to understand may stem from an inability to put into relationships the ideas and concepts with which they are bombarded. For the middle or junior high years, it is a big jump for many students from reading instruction in a basal series to reading serious literature. It becomes necessary to help students rearrange ideas, actions, events, characters and words in a reading assignment into groups of relationships which serve as more efficient means for remembering the basic themes of what is read. The reader is made aware of the details (names, places, behaviors, incidents, settings, descriptions and dialogue) of the story from which he can then group these details and inferences into more encompassing, more abstract, yet understandable, units of thought through the process of categorization and association.

1. The construction of a concept guide follows a two-step process similar to the steps involved in learning. To construct a concept guide:

- (1) Analyze the reading passage to determine the major concepts which the student should understand after reading. These words and phrases will be used in Part II of the guide.
- (2) Reread the work and choose statements which exemplify or illustrate the major concepts chosen for emphasis.

2. The use of the concept guide follows a pattern of response, then categorization.

- (1) Students respond to the statements in Part I. These may have only correct answers or responses where a student must defend his choice of answer.
- (2) Students categorize responses into appropriate groups represented by the major understandings of the reading. Again, the student should be able to defend choices made.

The following example of a concept guide represents a possible method of helping students think, reason and read. Students are capable of constructing guides once they have had experience with them.



*Auto Wreck* by Karl Shapiro

Part I. In the space provided below check the words or phrases used in the poem (do not check those not used). In a phrase or two tell what the checked words describe or refer to (e.g., ambulance, policeman, observer, auto wreck, victims).

- 1. quick soft silver bell \_\_\_\_\_
- 2. pulsing out red light like an artery \_\_\_\_\_
- 3. the zodiac \_\_\_\_\_
- 4. wings in a heavy curve \_\_\_\_\_
- 5. the mangled \_\_\_\_\_
- 6. we are deranged \_\_\_\_\_
- 7. making notes under the light \_\_\_\_\_
- 8. the hand that held my wrist \_\_\_\_\_
- 9. husks of locusts \_\_\_\_\_
- 10. our throats were tight as tourniquets \_\_\_\_\_
- 11. common sense \_\_\_\_\_
- 12. our richest horror \_\_\_\_\_
- 13. by hands \_\_\_\_\_
- 14. flower \_\_\_\_\_
- 15. wicked stones \_\_\_\_\_

Part II. Below are several words which reflect some feelings or ideas which seem to be in the poem. Write the words or phrases from Part I under the word(s) to which they apply. You may use other words from the poem also. Compare and defend your choices if they differ from someone else's.

Innocence      Life      Sanity      Insanity      Death      Guilt

There is no set form for a concept guide. The process of construction identifies the major ideas that the teacher believes to be important. If other concepts emerge from the reading, the student is enriched.

Concept guides are not tests. They are opportunities for students to think through ideas, to commit their ideas to the scrutiny of the teacher and their fellow students. There may be better answers, but the only wrong answers are those which are undefended. The process of thinking, rethinking, defending, changing or standing pat should be the emphasis of the guide and not the answer.

### 3. Teaching Reading in a Heterogeneous Class Using One Book

- (1) Technique: The Profundity Scale.\* For *The Adventures of Huckleberry Finn*, all students will read at least chapters 5-7, 8-10, 14-15, 17, 19-23 and 31.\*\*

\*Eileen E., Sargen, Helen Huus, and Oliver Andresen, *How to Read a Book* (International Reading Association, 1970).

\*\*Keith Larson and Sharyn Stump, LaFollette High School, Madison, Wisconsin.

All study activities will engage students in thinking about the novel at the several levels of the scale. In developing the activities with students, the teacher will keep foremost in the planning (1) the individual student's awareness and needs and (2) the possibilities for interaction among members of the group.

Each day students will work on individual readings, viewings or writings. At appropriate times students will work in small groups or with the entire class.

The teacher will facilitate an open classroom environment: setting deadlines, evaluating individual and small group performance, promoting reading, participating in small group discussions, providing resources.

(2) Example Activities. Depending on each student's needs, the teacher will assign projects or activities appropriate to the various levels of the Profundity Scale.

- Physical Plane: Reader is aware of the actions of the characters.  
*Discussion Project* – With three other students, write a summary of the events which occurred in Pap's cabin just before Huck set out on his Mississippi journey.
- Mental Plane: Reader is aware of physical and intellectual actions.  
*Discussion Project* – With three other students, write an answer to this question: Why did Huck want Pap and others to think he had been murdered?
- Moral Plane: Reader is aware of actions in light of an ethical code.  
*Reading Activity.* Read M.L. King's *Letter From a Birmingham Jail*. Discuss with three other students: How does M.L. King justify his breaking of a law?  
*Panel Activity.* Prepare a panel in which you evaluate Huck's ethics based on three actions in the novel: (1) Huck's lie to Jim after the fog separation. (2) Huck's refusal to turn Jim in to the slave hunters. (3) Huck's decision "to go to hell" rather than fail Jim.
- Psychological Plane: Reader is aware of psychological forces which influence actions.  
*Panel Activity.* How does Huck feel about his moral commitment to Jim? Trace the roots of this feeling from the first evidence of it at the Widow Douglas'.
- Philosophical Plane: Reader is aware of the universal truths exhibited.  
*Reading Activity.* Read James M. Cox, "Remarks on the Sad Initiation of Huckleberry Finn;" J.D. Salinger, *A Catcher in the Rye*, and John Steinbeck, "Flight."  
*Writing Activity.* Write a term paper dealing with this topic: *Rites des Passages* in American Fiction.

(3) Patterning and Pattern Guides. Bringing the student to an awareness of how the events of a story are related can be challenging. Students are interested in the action, the development of characters and how the story will end more than how the events are related. In order for students to discern relationships among characters, events and time, the patterns which an author uses are important for such an understanding. The following "signal words" are useful in identifying the techniques of an author or understanding a particular relationship in the story.

*Signal Words.* The following is compiled from notes of a lecture by Thomas H. Estes of the Reading Center at the University of Virginia.

**LISTING PATTERN**

the following	also
then	in addition
another	furthermore
finally	likewise
more over	as well as
besides	and
next	many
first	much
second	some
third	several
	lastly

**SEQUENCE PATTERN**

first	subsequently
second	until
third	while
last	meanwhile
soon	already
at last	next
then	after
now	during
immediately	in the meantime
ago	afterwards
at that time	

**CAUSE/EFFECT PATTERN**

for this reason	hence
in order to	thus
since	consequently
because	accordingly
so that	as a result
therefore	so
on account of	so that
	it follows that

**COMPARISON/CONTRAST**

even though	on the contrary
but	nevertheless
however	notwithstanding
yet	rather
otherwise	not
although	in spite of
on the other hand	in comparison
despite	conversely
still	

Note: Some of the words fit into more than one category, and the list is not intended to be comprehensive. Also, nothing will be gained by attempting to teach students this list. Kids already know these words and use them. However, we can and should sharpen their understanding of what these words DO in context.

- (4) Model of a Pattern Guide. From Paul A. Zahl, "The Magic Lute of Sea Shells," *National Geographic*, March, 1969, pp. 386-429.

You should read this article to find out what the various characteristics of mollusks are. The author is a sea shell collector, and the photographs will show you what a mollusk looks like. In addition, there are diagrams of the typical mollusk.

After you have read the article you will wish to remember some of the characteristics of some of the mollusks that you have read about. Notice the way the author has listed many of the characteristics in the article. You can aid your reading by looking at this structure of writing and listing the important facts.

From the group of mollusks in Group A, choose the appropriate name to match with the set of characteristics in Group B. You are looking at the listing of characteristics to find a name. So you are matching the name of the mollusk with the characteristics that it has. As an example, the snail on page 387 would be matched:

*Caribbean Snail*

has a spotted veil

has a pale orange shell

has a fleshy mantle which secretes limy substance to enlarge the shell

*You Might Add:*

has sensory tentacles and eyes located near feeding snout

scientific name: *Cyphoma gibbosa*

Names of the mollusks in the article are chiton, coquina clams, quahog, oyster, scallops, mussels, giant clams, pearl oysters, lithophaga, razor clams, murex brandaris, octopus, squids, conch and cowie.

Characteristics of some mollusks. Write the name in the blank, and add characteristics from your reading.

1. \_\_\_\_\_  
not a bivalve  
no shell  
has mantle and radula  
uses mantle for jet propulsion
2. \_\_\_\_\_  
provided purple dye for Phoenician traders
3. \_\_\_\_\_  
fan shaped shells called "butterflies" or "wedges"  
scientific name: *Donax*
4. \_\_\_\_\_  
are edible  
scientific name: *Crassostrea virginica*  
usually stays in one place the entire adult life
5. \_\_\_\_\_  
squirts a jet of water to wash out mud from hole  
larger hole allows this mollusk to pull himself in  
his danger comes from shipworms
6. \_\_\_\_\_  
scientific name: *Tridacna gigas*  
three feet long  
weighs several hundred pounds  
has a powerful clamp when shells come together
7. \_\_\_\_\_  
mantle produces a "coat of mail"  
uses ventral muscle, the foot, to cling to rocks  
uses radula, a tongue with teeth, to aid in eating algae

8. \_\_\_\_\_  
 classes of mollusk: Gastropoda – meaning “stomach foot”  
 relative of snail, slug  
 has had trumpets made from its shell
9. \_\_\_\_\_  
 secretes substance around an irritant to cause an object of value
10. \_\_\_\_\_  
 used for ornamentation, money, good luck charms  
 much variety in colors  
 found in many places around the world  
 described as shy; they shun sunlight
11. \_\_\_\_\_  
 burrows by secreting acid  
 can burrow into a rock  
 a relative can burrow a six-inch hole into concrete
12. \_\_\_\_\_  
 the shape of its shell has been used in history as a special symbol  
 it can leap and swim  
 while swimming it resembles a kite  
 uses jet propulsion  
 danger is usually from starfish

Awareness of patterns in reading should aid students in their writing. When they read a story which uses listing as a device, have them also write using listing. The reinforcing of the patterns aids their reading and adds to their versatility in composition, since they are using the reading as a model for expressing their ideas.

### C. ACTIVITIES FOR STUDENTS HAVING DIFFICULTY READING LITERATURE

1. Help the child to develop a story sense by telling short anecdotes and encourage the student to follow events and predict what could happen next. Encourage him to relate stories which he improvises as he tells them.
2. Assist the child in establishing purposes for reading a story such as determination of plot, description of setting and portrayal of characters.
3. Develop desire to read for humor and sparkling jokes. Encourage the child to tell those jokes which he has found interesting and help the child to emphasize the punch line.
4. Ask the child to find stories which can be dramatized. Have the child select one whose dramatization the child would like to direct. Permit the child to select characters and work out the play on the child's own.
5. Aid the child in finding books at the child's interest and reading level.

6. Encourage the student to read widely and in accordance with the child's personal tastes. The disabled and reluctant reader should not be restricted to prescribed reading lists.
7. Read a literary selection of interest aloud to a small group of students. Encourage discussion at the end of each reading but do not seek detailed analysis.
8. Develop background and readiness for reading. Many excellent readers lack the experience to interpret and react to a poem, a novel and even some short stories. Some teachers have encouraged several mature readers to participate in a panel discussion of the books they have read. The student lacking background can not only profit from this discussion but may be encouraged to read with zest the same book if it has been appraised highly by someone the student admires.
9. Demonstrate the use of imagery. The student can learn to make use of imagery, the visual, the auditory, the kinesthetic, the tactual and all sensory experiences. Sensory reactions, however, come only as a result of mental content and previous experiences.
10. Illustrate the underlying meaning of several selections. The student should look beneath the surface of mere words to discover deeper meaning.
11. Emphasize the value of reference materials. The dictionary and encyclopedia are helpful in aiding the student with his interpretation of metaphors and allusions. Textbooks in mythology and history are essential in approaching the latter. Books devoted to the language arts and literature can furnish background for the understanding of the various figures of speech. Literary reviews can provide the older student critical evaluations of contemporary plays and newly published novels.
12. Suggest that the student read leisurely. Literature should be taken slowly.
13. Stimulate an interest in short poems and show the student how to read them. Poetry reading can be interesting to people of all degrees of maturity since the poem is a word picture of many sensory experiences. Recordings of poems read by children not only add interest but can serve as a means of appraising growth. Some suggestions which can be helpful to the reluctant reader are listed.
  - Silently read the poem as a whole to obtain the central thought.
  - If some sentences are difficult, determine the subject and the verb and rearrange them in conventional order. Determine what the sentence actually says. What did the author accomplish by the unconventional arrangement?
  - Read the poem aloud in order to "catch" the rhythm and be able to adequately express the thought and emotional qualities of the poem.
  - Make the poem come to life and avoid an overemphasis on historical background, kinds of meter and figures of speech. All this can come later.
  - Identify phrases and lines of special interest and determine how the writer has made them effective.
  - Read the poem aloud to a friend and make sure that he, too, appreciates the excellent qualities of the selection. The student should understand that if the reader appreciates the emotional qualities of the poem, the student can express these to others.
14. Avoid frustrating the student.

D. **ROLE PLAYING.** An effective means of teaching appreciations, understandings and/or values is through dramatizations and role playing. The following are some guidelines to assure the success of role playing in the classroom.

1. It is helpful to begin by doing an easy warm up (such as "Red Rover, let Pete come over as a monkey," creating and passing around imaginary objects, etc.) to get students gently into playing roles.
2. Set the scene for both the actors and the audience and make sure everyone knows what is going on.
3. Make sure the actors know their roles very clearly (conducting an interview of the actors is a good way to do this and help them get into their roles).
4. Give the audience something to look for as they watch the role playing.
5. If side coaching is necessary, break in and do it obviously, so everyone knows what is going on.
6. If scene isn't coming to its own resolution, make it. Say something like: "Take two minutes now for a resolution."
7. Possibilities for involving more students and/or getting more into and out of the role play:
  - (1) Have characters switch roles during the role play, or have members of the audience take over a role during the role play (when this is done, break in, freeze the action, switch the characters and have the role play continue by repeating the last line that was said before you. This interruption will keep the flow of the role play going smoothly. It is often helpful to do this right after a challenging statement or really hard question has been asked).
  - (2) Have a student from the audience play the alter ego of one of the characters by getting behind the role player and adding comments that say what the person is thinking but not saying.
  - (3) Have members of the audience pick up on what they see and mimic it.
8. After role playing is finished, ask a sharp, focusing question to get discussion going and students focusing on the significance of what they saw.
9. It is often very helpful to have the students who were doing the role play to share their feelings, the feelings they experienced while they were playing their roles.
10. Magic circles are often a good follow-up for role playing, particularly when working out a problem.
11. Role playing can be used for:
  - (1) Making situations in books come alive.
  - (2) Identifying student concerns.

- (3) Role modeling which lets students try out new behavior.
- (4) Problem-solving.
- (5) Rehearsing which allows students to rehearse ways of handling situations they will meet.
- (6) Resolving conflicts.

E. **AN EXAMPLE OF A POETRY UNIT.\*** Although the following unit on poetry may be used for any grade level, the materials listed here are for an 8th grade class. It is assumed that discussion and anticipatory activities will be conducted prior to the manipulative activities that are listed.

UNIT: Poetry. The following concepts are suggested for emphasis in the poetry unit:

1. There are specific poetic devices:
  - a. alliteration
  - b. hyperbole
  - c. metaphor
  - d. onomatopoeia
  - e. personification
  - f. rhythm
  - g. simile
2. Poetry is a valid mode of expression.
3. Poetry frequently contains implied, extended meanings.
4. Every poem centers around a specific theme.
5. Poetry exists in many forms:
  - a. limerick
  - b. lyric
  - c. ballad
  - d. descriptive
  - e. narrative
  - f. humorous

Books and materials charted according to the concepts suggested above are listed in the next few pages. For example, if "1a" is indicated, alliteration is emphasized for that particular book or material.

*\*This poetry unit was developed by Candace Fix Bell, Montgomery County, Md.*



CONCEPTS	1a	1b	1c	1d	1e	1f	1g	2	3	4	5a	5b	5c	5d	5e	5f
<b>BOOKS AND MATERIALS</b>																
Introduction to Literature The Crafty Farmer								X	X	X			X			
Robin Hood and Alan a Dale								X		X			X			
On the Loss of the Royal George								X		X				X		
Ye Mariners of England								X		X					X	
<b>The Study of Literature</b>																
Silver – Walter de la Mare								X		X			X			
Fog – Carl Sandburg								X		X			X			
The Eagle – Alfred Lord Tennyson								X		X			X			
A Vagabond Song – Bliss Carman								X		X			X			
Robin Hood and Little John								X		X					X	
<b>Adventures for You</b>																
Horses								X		X						X
Not a Cloud in the Sky										X						X
Money										X						X
The Hippopotamus										X						X
Habits of the Hippopotamus										X						X
The Germ										X						X

CONCEPTS	1a	1b	1c	1d	1e	1f	1g	2	3	4	5a	5b	5c	5d	5e	5f
Three Limericks										X	X					X
The Illustrated Treasury of Children's Literature																
The Goops							X			X						X
Mud								X		X						X
Creatures in Verse	X	X	X	X	X	X	X	X	X	X	X	X	X	X	X	X
A World of Poetry	X	X	X	X	X	X	X	X	X	X	X	X	X	X	X	X
Poems by Eve Merriam "I" Says the Poem								X		X						
Thumbprint				X						X						X
Color				X						X						X
Kittens						X		X		X						
Onomatopoeia and Onomatopoeia II				X				X		X						
Authors Unknown Bugs										X						
There Was a Young Man										X	X					
A Fellow Named Hall										X	X					

CONCEPTS	1a	1b	1c	1d	1e	1f	1g	2	3	4	5a	5b	5c	5d	5e	5f
Bats -- Mary Effie Lee Newsome								X		X						X
I Wish -- G. Burgess						X				X						
The Raven -- E. A. Poe	X					X		X		X						
A Tutor -- Carolyn Wells	X															
There Was an Old Man From Japan -- William Jay Smith										X						
Poetry Written by Previous Students																
Peace Is -- Debbie Winson										X						
I Know Something -- Cheryl Aident										X						
Ocean -- Marcia Conklin										X	X					
Life -- Barbara Carter										X	X					
Roses -- Cynthia Woolum										X	X					
Mr. Fletcher -- Kathy Walker										X	X					
FILMSTRIPS																
Words That Rhyme						X										
Rhythm in Poetry						X										
Stanza Forms and Forms of Verse													X			
Figures of Speech		X	X	X	X		X									

FILMSTRIPS	1a	1b	1c	1d	1e	1f	1g	2	3	4	5a	5b	5c	5d	5e	5f
Getting Meaning From Poetry								X	X	X						
How to Write a Poem						X			X	X	X		X			
Sound Effects in Poetry	X			X			X									
<b>NEWSPAPERS</b>	X	X	X	X	X											
<b>MAGAZINES</b>	X	X	X	X	X											
<b>COMIC BOOKS</b>	X	X	X	X	X											
<b>RECORDS</b>																
Big Bad John -- Jimmy Dean							X		X	X			X			
Ode to Billy Joe -- Bobby Gentry							X		X	X			X			
Barbara Allen -- Joan Baez																
Reach Out and Touch -- Diana Ross							X			X			X			
<b>ACTIVITIES</b>																
Total Group. Select a person, a place and a thing, as three separate topics, and write three lyric poems according to the form discussed in class.										X			X			
Research the life of the poet of your choice. Review some of his poems. Note his style and favorite themes. Report your findings to the class in any manner you choose.										X			X			X

ACTIVITIES	1a	1b	1c	1d	1e	1f	1g	2	3	4	5a	5b	5c	5d	5e	5f
<p>Read "The Hunters" (<i>Creatures in Verse</i>). Complete the following questions:</p> <ol style="list-style-type: none"> <li>1. What stopped the hunter from shooting?</li> <li>2. How are the hunter and the fox alike?</li> <li>3. Is this a noisy poem? Why or why not?</li> <li>4. What feelings are you left with?</li> <li>5. Notice that the first four stanzas are of two lines, whereas the fifth is composed of three lines. Why do you think the last stanza has three lines?</li> <li>6. How many creatures are mentioned in each of the two-line stanzas? How many in the last stanza?</li> </ol>					X			X	X	X						
<p>Read "Tattoo" by Wallace Stevens and "The Mind Is an Enchanting Thing" by Marianne Moore (<i>Creatures in Verse</i>). Look at the photographs that illustrate each poem. Select the one that you like best. Discuss in writing or orally to the teacher whether or not you think that the illustration fits the poem.</p>														X		
<p>Small Group. Read "First Deer," "Navaho Hunting Song," or "The Buck in the Snow" (<i>Creatures in</i></p>																

**ACTIVITIES**

	1a	1b	1c	1d	1e	1f	1g	2	3	4	5a	5b	5c	5d	5e	5f
<p><i>Verse</i>). Answer the following questions for one of the poems and discuss them with your group. Try to come to a consensus on the answers.</p> <ol style="list-style-type: none"> <li>1. What story does the poem tell, or what picture does it present?</li> <li>2. Explain how you know how the hunter felt.</li> <li>3. How do you know how the prey felt?</li> <li>4. How does the poet feel about this theme?</li> </ol>								X	X	X				X		
<p>As a group project, find and copy one poem for each of the following themes:</p> <ol style="list-style-type: none"> <li>1. love</li> <li>2. peace</li> <li>3. war</li> <li>4. happiness</li> <li>5. death</li> </ol> <p>Tell the source of your poems.</p>						X		X	X	X			X	X		X
<p>As a group select three one-word themes. Jointly write three poems. One may be in any form, one must have end rhyme and one must have internal rhyme.</p>						X		X								
<p>Find one poem using alliteration and one using onomatopoeia. Share the poems with your group, telling the theme and form of each.</p>	X				X			X		X	X	X	X	X	X	X

ACTIVITIES	1a	1b	1c	1d	1e	1f	1g	2	3	4	5a	5b	5c	5d	5e	5f
<p>Individual. Look up one of the following animals in the dictionary:</p> <p>phoenix            sphinx centaur            mermaid dragon             minotaur griffin             unicorn</p> <p>If a picture is given, copy it. Write a descriptive poem from the information you receive from the dictionary.</p>								X						X		
<p>Choose ten animals from the Steig animal cartoons. Find a partner and discuss what type of human personality each represents.</p>						X		X	X	X						
<p>Find five examples of onomatopoeia in newspapers, magazines or comic books. Cut them out and form a scrap book with your clippings.</p>				X												
<p>Write a poem in which you describe one of the following:</p> <ol style="list-style-type: none"> <li>1. A cat coming out from underneath a car.</li> <li>2. A pigeon pecking street gravel.</li> <li>3. A dog running after a thrown stick and returning with it in his mouth.</li> <li>4. Any other animal in motion that you may think of.</li> </ol>								X						X		

ACTIVITIES	1a	1b	1c	1d	1e	1f	1g	2	3	4	5a	5b	5c	5d	5e	5f
Find examples of each of the following: 1. simile 2. hyperbole 3. metaphor 4. personification 5. alliteration Make some type of booklet with your examples. Label each group and tell where each example came from.	X	X	X		X		X									
Draw several cartoons that are part human and part animal. Write a short poem about each.								X		X				X		X
Read "Bats." Copy the lines that describe the feelings that most people have toward bats.								X		X			X			
Create an imaginary thing. Draw a sketch of it. Think about the noises it makes, how it moves and where it lives. Give your thing a name. Write a narrative poem about 24 hours in your thing's life.															X	X
Choose any creature that you can think of and write a stanza for Sandburg's "Wilderness." Try not to make your stanza the last one.								X		X						



ACTIVITIES	1a	1b	1c	1d	1e	1f	1g	2	3	4	5a	5b	5c	5d	5e	5f
Make a crossword puzzle or a game using the poetic devices discussed in class.	X	X	X	X	X	X	X									
Write a series of poems, one in each of the seven forms discussed, on a theme of your choice. Be sure to use some of the poetic devices.	X	X	X	X	X	X	X			X	X	X	X	X	X	X
Select a picture that you really like. Mount it on a piece of construction paper and write a poem about it.								X		X						

The following is to aid both the student and the teacher in evaluating progress made while completing the poetry unit.

### UNIT EVALUATION

Name \_\_\_\_\_

Class \_\_\_\_\_

Week of \_\_\_\_\_

Grade of week \_\_\_\_\_

*Comment Key*

- 1 - Enjoyed work
- 2 - Found work useful
- 3 - Needed help
- 4 - Assignment not interesting

*Evaluation Key*

- 1 - Very good
- 2 - Satisfactory
- 3 - Unsatisfactory

Group \_\_\_\_\_

MONDAY	No.	Student Comments	Student Evaluation	Teacher Evaluation
A. Group work B. Individual work C. Learning station D. Discussion group				
TUESDAY A. Group work B. Individual work C. Learning station D. Discussion group				
WEDNESDAY A. Group work B. Individual work C. Learning station D. Discussion group				
THURSDAY A. Group work B. Individual work C. Learning station D. Discussion group				
FRIDAY A. Group work B. Individual work C. Learning station D. Discussion group				

# 12 Skill Strategies

## A. CONTENT READING

1. **The Ames Classification Scheme for Context Clues.** The following is compiled from W.S. Ames, "Use of Classification Schemes in Teaching — the Use of Contextual Aids," *Reading Research Quarterly*, XIV (October, 1970), pp. 5-8.

(1) Clues derived from language experience of familiar expression:

I wonder how much the security of the country is being safeguarded by the paunchy reservist who spends one evening a week at the Reserve Center \_\_\_\_\_ the fat with the boys, thereby escaping from the dishes at home.

(2) Clues utilizing modifying phrases or clauses:

The Great Atlantic and Pacific Tea Company, operating on the \_\_\_\_\_ that all the housewife really wants is high quality at the lowest price, became the Goliath of the industry.

(3) Clues utilizing definition or description:

One towering worry is the problem of the professional \_\_\_\_\_. A few who sell blood — nurses, medical students, professors of rare types — have been carefully screened.

(4) Clues provided by words connected or in series:

Under questioning, Kendricks broke down and \_\_\_\_\_ the policeman's murder.

(5) Comparison or contrast clues:

The draft was dropped after World War II, but \_\_\_\_\_ in 1948, following a bitter nationwide debate.

(6) Synonym clues:

Their achievement was so breath-taking that it \_\_\_\_\_ — and still provokes — a kind of idolatry and the great controversy.

(7) Clues provided by the tone, setting and mood of a selection:

The most withering insult that can be hurled at a man today is "leftist" — a term almost synonymous with "Communist." We \_\_\_\_\_ as the sensitive ears developed by all minority members pick up such expressions as "left-handed compliment" and "left-handed thinking."

(8) Referral clues:

Look at the figures for deaths that occur at birth or during the first year of life for every 100 infants in these countries.

Sweden, 15.3  
United States, 25.3

These \_\_\_\_\_ carry an unpleasant message.

(9) Association clues:

The *American Medical Association Journal* states that brutal physical punishment by parents is likely to be "a more frequent cause of death than such well-recognized diseases as leukemia, cystic fibrosis and \_\_\_\_\_ distrophy."

(10) Clues derived from main idea and supporting details paragraph organization:

Sales shot up. From 19 small stores, in which he grossed about \$3 million dollars, Jenkins has \_\_\_\_\_ to 98 Publix stores, which last year grossed \$215 million.

(11) Clues provided through the question-and-answer paragraph organization:

And what about \_\_\_\_\_ itself? The English language has been designed with sinister malice by sinister right handers to be written with the right hand, i.e., from left to right.

(12) Preposition clues:

Respectable folk in the middle and upper classes would have been horrified at the idea of a pipe or a cigar between feminine \_\_\_\_\_.

(13) Clues utilizing non-restrictive clauses or appositive phrases:

In the emergency room, they would then claim they had been injured when a heavily insured car (owned by another member of the gang) plowed into them, \_\_\_\_\_ at a bus stop.

(14) Clues derived from cause and effect pattern of paragraph and sentence organization:

He reads not for fun but to improve his mind and render his conversation less \_\_\_\_\_.

2. **The Strang/McCullough/Traxler Classification Scheme for Context Clues.** The following is compiled from R.M. Strang, Constance McCullough and Arthur Traxler, *The Improvement of Reading*, 4th ed. (New York: McGraw-Hill Book Co., 1967), pp. 230-231.

(1) Direct explanation: The unknown word is explained in the sentence.

To talk aimlessly in a rambling way about the weather, the war, your new dress, the class play, is to carry on a *desultory* conversation.

In Roman times a member of the nobility was called a *patrician*.

(2) Experience: The meaning of the unknown word can be supplied by something in the student's life-experience.

At Thanksgiving and Christmas *indigent* families are fed by the Salvation Army.

- (3) Comparison and contrast: The unknown word has a meaning that is opposite to that of a known word.

Ed was talkative while Bill remained *taciturn*.

- (4) Synonym or restatement:

The *sorcerer*, a wizard of great reputation for villainy, gazed scornfully at his victim.

- (5) Familiar expression or language experience: The student can decipher the word by drawing on his acquaintance with everyday expressions and common language patterns.

The drowning man was carried to the beach, where he was given artificial *respiration*.

- (6) Summary: The unknown word summarizes the ideas that precede or follow it.

At the age of 85 the king was still playing a skillful game of tennis. He seldom missed his daily swim. For a man of his age he was very *robust*.

- (7) Reflection of a mood or situation: The unknown word fits a situation or a mood that has already been established.

As she said goodnight after the prom, the boy she cared for most asked her to wear his fraternity pin. Her joy was *ineffable*.

3. Context Clues: Review/Reinforcement. In each of the following sentences or groups of sentences a word has been deleted. Write the missing word in the blank space.

- (1) So, too, much stress has been placed on \_\_\_\_\_ effects – the influence of psychic states (i.e., the mind) on the body and its processes.

- (2) Foremost, of course, drivers need to realize that by cheating the insurance companies, they are only pushing their own premiums \_\_\_\_\_

- (3) It was night that the young teacher dreaded, after they grew too tired to play. How could she keep them warm against the wind that rattled the windows and made the \_\_\_\_\_ little building tremble? White frost filled every crack. The children shivered if they left the circle around the fire.

- (4) Surely it will take 100 Louvres and Metropolitan Museums to house the paintings of the future and thousands of orchestras to \_\_\_\_\_ the new symphonies.

- (5) My sons are nine and seven, and the high point of their week is Saturday morning, when, having done their jobs and received their allowances, they return from the store with a sheaf of new comics, mystic expectation written all over their \_\_\_\_\_.

- (6) All of you have \_\_\_\_\_ that carry messages to and from the various parts of your bodies and direct their work.

- (7) Knowing that women usually don't want anything they have to peel, suck, scrape, chop or wash through three waters, Jenkins started doing these \_\_\_\_\_ at the store.
- (8) To give the submarine the continual attention it needs, the officers and crew are divided into watches. A \_\_\_\_\_ is a four-hour period of duty.
- (9) Not a single chair was to be seen, and my whole body was trembling from the \_\_\_\_\_ chill that had entered my veins.
- (10) What will we do with all this spare time? Will it be a blessing or a \_\_\_\_\_?
- (11) "Give me \_\_\_\_\_ of it, that surfeiting, the appetite may sicken and so die."
- (12) Although professional cheaters are the most spectacular, insurance firms suffer a great collective financial loss from ordinary citizens who seem to feel that bilking an insurance company is one of life's permissible moral transgressions. Like the \_\_\_\_\_, they often have the connivance of shady repairmen, doctors, attorneys, even insurance adjustors.

## B. WORD ANALYSIS AND VOCABULARY DEVELOPMENT

### I. Phonic Principles

- (1) The vowel in a syllable which ends with one or more consonants (a closed syllable) has a short sound. (ash, cell, fifth, ton)
- (2) A vowel which is the final letter of a syllable (an open syllable) is usually long. (villi, zero, ratio)
- (3) A syllable having two vowels, one of which is a final *e*, usually has the long sound of the first vowel with the final *e* silent. (nitrate, secede, lime, node, cube, dye)
- (4) The sound of a vowel followed by the letter *r*. Specifically, *a* or *o* followed by *r* is neither long nor short. The vowels *i*, *e* and *u* followed by *r* sound the same. (arbitrate, vermin, internal, force)
- (5) In words that contain two vowels together (digraph) such as *ai*, *ay*, *oa*, *ee*, and *ea*, usually the first is long and the second is silent. (impeach, brain, steam, ray, steel)
- (6) In words that contain two consonants together such as *au*, *aw*, *eu* and *oo*, the vowel letters (digraphs) have a special sound unlike either of the vowels. (caustic, pasteurize, food, sewage)
- (7) In words that contain two consonants together such as *sh*, *wh*, *th* and *ch*, the consonant letters (digraphs) produce a single and new sound. (ship, wheat, this, third, change, chorus)

- (8) Some words have a blend of two or more consonants, each of which retains its own sound. (blood, stomach, gland, trade)
- (9) Some words have a blend of two vowels (diphthongs) which produces a blended sound. (coil, boycott, mouth)
- (10) When *c* or *g* is followed by *e*, *i* or *y*, each is usually soft. (city, century, cyst, geometric, gyroscope)
- (11) The unaccented syllable of a word may cause the vowel to have the *schwa* sound (the *schwa* sound designated by the inverted *e* (ə) is indistinct and does not give the vowel a distinctive sound). (respiration, corolla, ventral, quadrupled)

2. **Word Analysis Skills.** Some of the ways in which a good reader can identify an unknown word are the following:

- (1) He guesses from context, the rest of the sentence showing what the missing word must be.
- (2) In addition to the context, he makes use of the first letter or two and the general shape or configuration of the word. Example: After getting out of the car, Mr. Smith went into the g\_\_\_\_\_.
- (3) Consonant substitution. He notes that the word is similar to a word he knows except for one or two letters, the sounds of which he knows. Example: "mast" – knowing "fast" and *m*, he mentally substitutes the sound of *m* for the *f* to get "mast."
- (4) He divides the word into large parts which he already knows as units, such as "super - im - position" and "post - master."
- (5) He notes that the word consists of a familiar root and ending, "playing" – *play* and *ing*.
- (6) He looks for familiar little words within longer words, "candidate" – can - did - ate.
- (7) He analyzes words structurally into known prefixes, roots and endings, such as "reporter" – re - port - er.
- (8) He applies phonic rules, such as the effect of final *e* on preceding vowels. Examples: "cane" – knowing *can* and the rule, he gives the *a* its long sound. "Decent" – knowing that *c* is soft before *e*, *i* or *y*, he uses the sound of *s* instead of the sound of "k."
- (9) He uses syllabication, dividing into syllables structurally and sounding the syllables phonically, "unfortunate" – un - for - tu - nate.
- (10) He thinks of a "word family" to which the word belongs. Example: "fright" – he recognizes it as belonging to the *ight* family along with night, right and fight.

- (11) He sounds the word out by groups of letters and blends the sounds together, "treaty" – *tr - eat - y* or *tre - a - ty* or *trea - ty*.
- (12) He sounds the word letter by letter and then blends the sounds together, "pant" – *p - a - n - t*.
- (13) He looks the word up in the dictionary and uses the dictionary's syllable divisions, accent marks and diacritical marks or phonetic respelling to get the correct pronunciation. (He chooses the appropriate definition for the context.)

Some of the techniques described above (2, 3, 8, 10, 11, 12) are phonic techniques; still others (9, 13) involve both phonic and structural analysis principles. With all of them, the good reader is constantly aware of the meaning of the sentence in which the word is found. Teachers must lead students to expect exceptions and to use intelligent trial and error when the first attempt to solve the word does not make sense. For further information consult sources cited in the bibliography at the end of this chapter.

### C. VOCABULARY REINFORCEMENT ACTIVITIES

1. **Things to Do.** Choose your activities from the following list:

- (1) Choose five words that have more than one meaning.
- Write the word in the sentence the book uses.
  - Look the word up in the dictionary.
  - Write down the dictionary meaning which you think fits the sentences.
- (2) Find as many words as you can that can be made plural. Write the word, then write it as a plural. (dog, dogs)
- (3) Write five words that gave you trouble or that you think might be hard for someone else in the class. Make a "dictionary" of the words.

2. **Word Maze.** The words in the following maze are words pertaining to linguistics; you may find a word in a horizontal word, in a vertical word, in a diagonal word or in a reverse diagonal.

Find as many as you can; there may be hidden words or secret messages. Here are the words you are looking for:

Intonation  
Patterns  
Grammatical  
Terminals  
Language  
Transformations

Phoneme Grapheme  
Linguistics  
Morpheme  
Imperative  
Words  
Meanings

Junctures  
Phonology  
Study Human Language  
Structure  
Declarative



L A T I N O V E J I C A K E U J A B C Y O U S E N T E N C E Y  
 I N T O W E A R S T R A I G H T O N C E W A R W E B D K L E X  
 N P H O N E M E O G R A P H E M E R E L A T I O N S H I P S I  
 G O T V T E R M I N A L S E A T S R J U S T I R Y E T V R A D  
 U Y P R P H O N O L O G Y D O U G L A S Y E S D S P E R I F F  
 I P A T T E R N S I N T O N A T I O N M Y P S E L K Q I F A M  
 S T A R P E R S G N U K L D V E R T I C A L G I F T U J U G I  
 T A R D H V G R A M M A T I C A L O T B U S M E A N I N G S P  
 I R A T E X U B A L A N C E D U E N O W Z P D O C J L D C O T  
 C O H W M D E C L A R A T I V E Y E A R N S E T O T B U C U O  
 S T U D Y Y E T I G E R R A T S B A R N Y U R P E U Q U N E P  
 P O M M M T U U S E T H E L A S T T I O M A B C R I T I O S E  
 L E A D I N T E R O G A T I V E S K I O E O T D O E T O O P Y  
 L A N G U A G E E D I S C J U S T I C E W A Y I I O S E W A Q  
 J J O R T I O R W P P R Y T W X Z M N O P R D V M E Y O U W E  
 L E A V E M E A L O N E T O D A Y A S I M V E R Y T I R E D I

Word mazes can be used effectively as games, interest stimulators, vocabulary review, end-of-the-period reviews or word recognition exercises for "hard to motivate" students. Mazes could be worksheets, interest or learning centers; they shouldn't be used every day or for every exercise, but they do promote discovery in a treasure hunt mood.

3. **An Alphabet Challenge.** Can you write an alphabet story? A full alphabet story starts A and runs to Z. It sounds simple, but it isn't! Here's a sample. Remember A through Z:

Archie Bunker cuts down Edith: finds great happiness in just kidding Lionel: makes nasty, outrageous, petty quips regarding son-in-law: teases us viewers with x-traordinary yelling zest.

Easy? Now write a full paragraph that starts Z and goes backward to A!

"Zelda, your xylophone was very untuneful today. Sloppy, rather quick practice? Or not many lessons? Kitchen jobs interfered. Homework got fairly exhausting! Don't complain. Better act!"

4. **Dialect.** Match the words in the two columns:

- |                  |                    |
|------------------|--------------------|
| 1. skunk         | a. spider          |
| 2. roasting ears | b. bedspread       |
| 3. cantaloupe    | c. lightwood       |
| 4. seed          | d. tap             |
| 5. kindling      | e. polecat         |
| 6. green beans   | f. milk shake      |
| 7. johnnycake    | g. pancakes        |
| 8. pot cheese    | h. shucks          |
| 9. griddle cakes | i. blind           |
| 10. window shade | j. cottage cheese  |
| 11. frappe       | k. snap beans      |
| 12. faucet       | l. corn bread      |
| 13. husks        | m. pit             |
| 14. counterpane  | n. corn on the cob |
| 15. skillet      | o. muskmelon       |

5. **Anagrams.** Make one anagram from each of the words listed below. Rearrange all the letters of the word to make a new one:

1. live
2. nail
3. leap
4. share
5. anger
6. poem
7. Dwight D. Eisenhower

In addition, use all letters and make at least one new word from these:

mug	soil
nit	thorn
petal	smug
vales	shrub
pokes	moral
care	peaks
hate	angle
swore	score
ports	part
rote	near
awl	lion
grape	poles
grown	later
fowl	trace
verse	tested
sole	male
lure	date
brag	diary
porter	rage
drapes	tend
form	detail
petals	salt
peels	clean
tapes	tier
lime	lair
retell	resist
strap	mean
past	tarp
peas	rare
asleep	acre
danger	plum
veto	lore
dilate	pier
enlarge	prod
risen	spread
ant	break
pit	pore
tills	laid
silt	ward

leap  
lap  
apt  
groan  
arid  
rate  
hoes  
step  
battle  
cork  
dire  
file  
shale

emit  
lips  
pried  
ream  
peach  
chum  
there  
aunt  
scorn  
broth  
mar  
silent

6. **Exercises — Wild Mustard.** The wild mustard in Southern California is like that spoken of in the New Testament, in the branches of which birds of the air may rest. Coming out of the earth, so slender a stem that dozens can find starting points in an inch, it darts up, a slender straight *shoot*, five, ten, twenty feet, with hundreds of fine *feathery* branches locking and interlocking with all the other hundreds around it, until it is an *inextricable* network like lace. Then it bursts into yellow bloom still finer, more feathery and *lacelike*. The stems are so *infinitesimally* small, and of so dark a green, that at a short distance they do not show, and the cloud of blossom seems floating in the air; at times it looks like golden dust. With a clear blue sky behind it, as it is often seen, it looks like a golden snow storm. The plan is a *tyrant* and a *nuisance* — the terror of the farmer; it takes *riotous* possession of a whole field in a season; once in, never out; for one plant this year, a million the next; but it is impossible to wish that the land were *freed* from it. Its gold is as distinct a value to the eye as the *nugget* gold is in the pocket.

#### Vocabulary Exercises

- (1) Choose the best synonym you can think of for the following words from the paragraph above.

feathery: \_\_\_\_\_  
nuisance: \_\_\_\_\_  
nugget: \_\_\_\_\_

- (2) Using your dictionary, check the origin of the word "tyrant" and trace its changes in becoming its present form.
- (3) Separate the following words into prefix, root word and suffix and give a definition for each.

inextricable: \_\_\_\_\_  
infinitesimally: \_\_\_\_\_

- (4) Using the context of the passage above, give a suitable definition for the following words as they are used in the paragraph.

shoot: \_\_\_\_\_  
riotous: \_\_\_\_\_  
freed: \_\_\_\_\_

(5) Write five original sentences using any five of the 10 underlined words above.

---



---



---



---



---

7. **The Words and Titles of Dylan Thomas.** The following activity asks that YOU be familiar with some titles of Dylan Thomas' poetry. As you try to match the clues at the bottom of the page in order to fill in the blanks above, you may wish to read a number of the poems or review the table of contents of *Dylan Thomas: Collected Poems*. Be ready to defend your choices.

1.                    - - - - - D - - - - -
2.                                         - - - - - Y - - - - -
3.     - - - - - L - - - - -
4.     A - - - - -
5.     - - - - - N - - - - -
6.     - - - - - T - - - - -
7.     - - - - - H - - - - -
8.     - - - - - O - - - - -
9.     - - - - - M - - - - -
10.     - - - - - A - - - - -
11.     - - - - - S - - - - -

1. " - - - - - D - - - - -, by Fire, of a Child in London"
2. "A girl mad as birds"
3. one must rage and live life, or youth on the farm
4. images of a church at night
5. the poet writes for a muse, not for critics
6. How does one elegize or lament a death?
7. "poem in October" concerns Thomas' - - - - -.
8. Refuse passivity in the face of death.
9. The "Hunchback in the Park" was a - - - - -.
10. Thomas' wife: first name
11. "I see the - - - - - in their ruin"

# 3 Study Techniques

Psychologists at top universities have been experimenting for years to find out how students learn and how they learn most easily. Learning has become a science based on well-established principles. Methods that have proved effective with thousands of college students are called "higher-level study skills." Through these, many students learn more easily, remember longer and conserve their study time.

Having students totally independent to gain information for themselves is the goal of study skills. The acquisition of content increases with the teaching of these skills. The following is a checklist of study skills to be used by the teacher to determine the level of study skills each student possesses.

**A. CHECKLIST OF STUDY SKILLS.** The following is compiled from R. Karlin, *Teaching Reading in High School* (New York: Bobbs Merrill, 1964), pp. 187-188.

*Study Skills*

1. Selection and Evaluation	Level of Student's Performance		
Can the student do the following?	Good	Poor	Fair
a. recognize the significance of the content	<input type="checkbox"/>	<input type="checkbox"/>	<input type="checkbox"/>
b. recognize important details	<input type="checkbox"/>	<input type="checkbox"/>	<input type="checkbox"/>
c. identify unrelated details	<input type="checkbox"/>	<input type="checkbox"/>	<input type="checkbox"/>
d. find the main idea of a paragraph	<input type="checkbox"/>	<input type="checkbox"/>	<input type="checkbox"/>
e. find the main idea of larger selections	<input type="checkbox"/>	<input type="checkbox"/>	<input type="checkbox"/>
f. locate topic sentences	<input type="checkbox"/>	<input type="checkbox"/>	<input type="checkbox"/>
g. locate answers to specific questions	<input type="checkbox"/>	<input type="checkbox"/>	<input type="checkbox"/>
h. develop independent purposes for reading	<input type="checkbox"/>	<input type="checkbox"/>	<input type="checkbox"/>
i. realize the author's purpose	<input type="checkbox"/>	<input type="checkbox"/>	<input type="checkbox"/>
j. determine the accuracy and relevancy of information	<input type="checkbox"/>	<input type="checkbox"/>	<input type="checkbox"/>
2. Organization			
Can the student do the following?			
a. take notes	<input type="checkbox"/>	<input type="checkbox"/>	<input type="checkbox"/>
b. determine relationship between paragraphs	<input type="checkbox"/>	<input type="checkbox"/>	<input type="checkbox"/>
c. follow time sequences	<input type="checkbox"/>	<input type="checkbox"/>	<input type="checkbox"/>
d. outline single paragraphs	<input type="checkbox"/>	<input type="checkbox"/>	<input type="checkbox"/>
e. outline sections of a chapter	<input type="checkbox"/>	<input type="checkbox"/>	<input type="checkbox"/>
f. outline an entire chapter	<input type="checkbox"/>	<input type="checkbox"/>	<input type="checkbox"/>
g. summarize single paragraphs	<input type="checkbox"/>	<input type="checkbox"/>	<input type="checkbox"/>
h. summarize larger units of material	<input type="checkbox"/>	<input type="checkbox"/>	<input type="checkbox"/>
3. Location of Information			
Can the student do the following?			
a. find information through a table of contents	<input type="checkbox"/>	<input type="checkbox"/>	<input type="checkbox"/>

	Good	Poor	Fair
b. locate information through the index	<input type="checkbox"/>	<input type="checkbox"/>	<input type="checkbox"/>
c. use a library card catalog to locate materials	<input type="checkbox"/>	<input type="checkbox"/>	<input type="checkbox"/>
d. use of the <i>Readers' Guide to Periodical Literature</i> to locate sources of information	<input type="checkbox"/>	<input type="checkbox"/>	<input type="checkbox"/>
e. use an almanac to obtain data	<input type="checkbox"/>	<input type="checkbox"/>	<input type="checkbox"/>
f. understand and use various appendixes	<input type="checkbox"/>	<input type="checkbox"/>	<input type="checkbox"/>
g. use glossaries	<input type="checkbox"/>	<input type="checkbox"/>	<input type="checkbox"/>
h. use encyclopedias to locate information	<input type="checkbox"/>	<input type="checkbox"/>	<input type="checkbox"/>
4. Following Directions			
Can the student do the following?			
a. see the relation between the purposes and the directions	<input type="checkbox"/>	<input type="checkbox"/>	<input type="checkbox"/>
b. follow one-step directions	<input type="checkbox"/>	<input type="checkbox"/>	<input type="checkbox"/>
c. follow steps in sequence	<input type="checkbox"/>	<input type="checkbox"/>	<input type="checkbox"/>
5. Specialized Skills			
Can the student do the following?			
a. understand the significance of pictorial aids	<input type="checkbox"/>	<input type="checkbox"/>	<input type="checkbox"/>
b. read and interpret graphs	<input type="checkbox"/>	<input type="checkbox"/>	<input type="checkbox"/>
c. read and interpret tables	<input type="checkbox"/>	<input type="checkbox"/>	<input type="checkbox"/>
d. read and interpret charts	<input type="checkbox"/>	<input type="checkbox"/>	<input type="checkbox"/>
e. read and interpret maps	<input type="checkbox"/>	<input type="checkbox"/>	<input type="checkbox"/>
f. read and interpret cartoons	<input type="checkbox"/>	<input type="checkbox"/>	<input type="checkbox"/>
g. read and interpret diagrams	<input type="checkbox"/>	<input type="checkbox"/>	<input type="checkbox"/>
h. read and interpret pictures	<input type="checkbox"/>	<input type="checkbox"/>	<input type="checkbox"/>

Francis Robinson's Survey, Question, Read, Recite and Review procedure for study is one of the most common yet seldom used. Students feel that too much time is involved with this procedure, but they fail to recognize that employment of the technique brings greater retention of information found in the material read, making it more useful for fulfilling a given assignment.

- B. **NOTE TAKING.** Note taking or outlining is an essential part of study type reading. It compels the student to think about what he is reading, and it is excellent for review. Note taking may be done in a variety of ways other than the traditional outline form. The following are some more interesting models that students may want to follow.

I. Pyramid – good for nonfiction; shows the relation of each part to the whole.

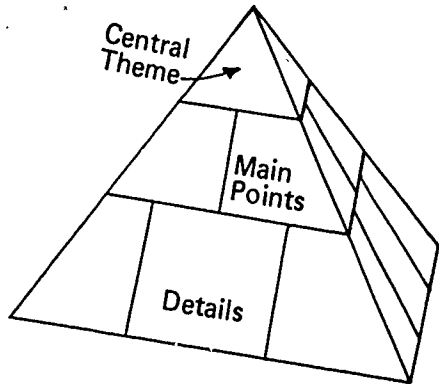

II. Cellular Structure – illustrates dependent relationship of the central theme to its part.

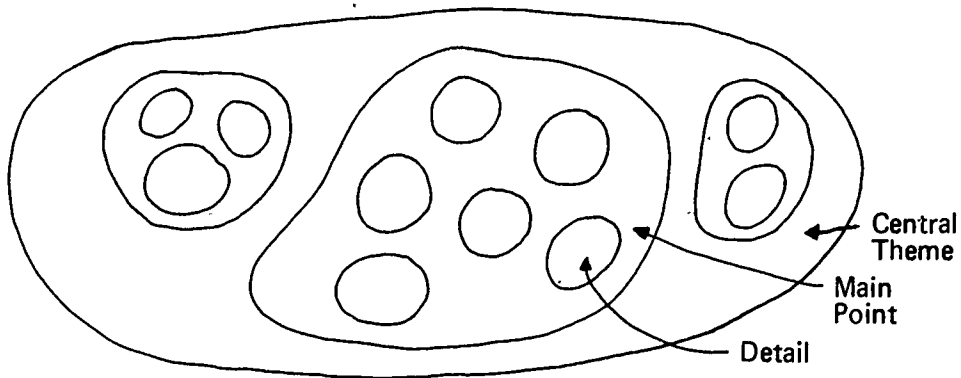

III. Overlapping Structure – good for writing where ideas are all interrelated.

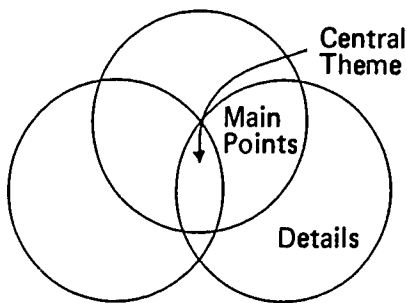

IV. Radial

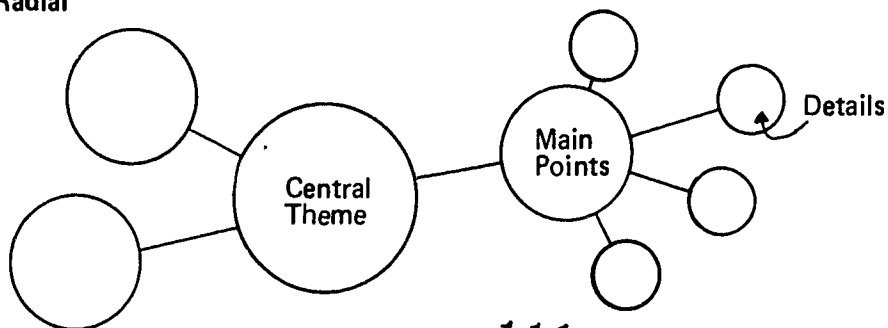

111

Mapping, a simple technique of structuring information in graphic form, is as old as the flow chart and the sentence diagram, and as new as the theoretical model design and the tree diagram of transformational grammar. Used as a study technique with the Survey, Question, Read, Recite and Review procedure as an aid to recall, with an approach to rapid reading like Evelyn Wood's, and as a substitute for note taking and outlining, mapping is worthy of careful consideration for increasing reading comprehension and retention.

If you have ever designed a flow chart, you know the basic procedure for map making. In a flow chart of any graph, the information is arranged in hierarchical order of intellectual importance. Words are kept at a minimum. The effect is that of perceptual comprehension rather than verbal. Instead of reading the information, one sees it. The Gestalt, seeing the whole and all its related parts, yields a powerful impact, immediate comprehension and easy retention. The student can easily design a map in three basic steps, identifying (1) main ideas, (2) secondary categories and (3) supporting details. The following is an example of a monster map.

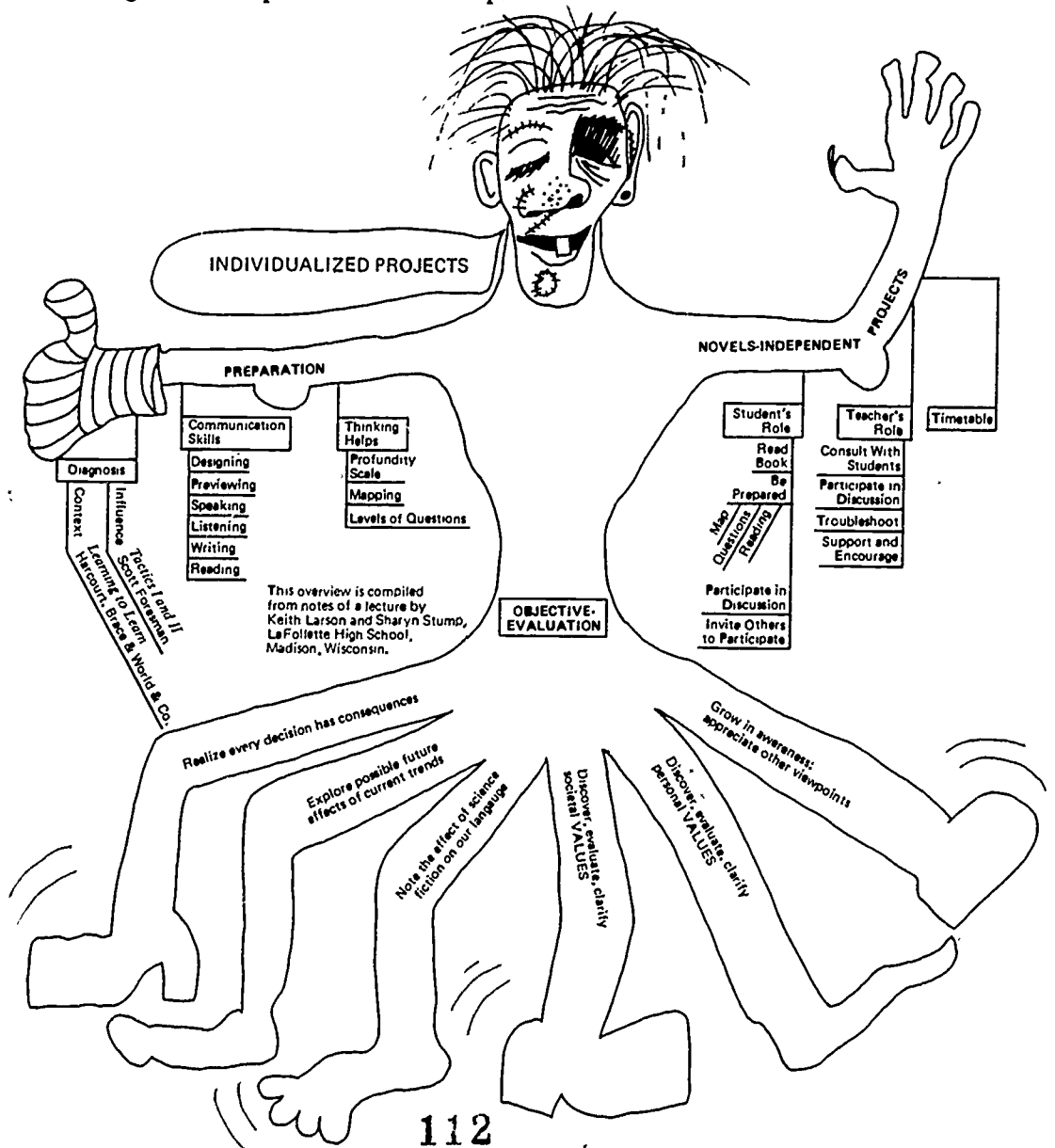

112

126



The dictionary is a useful study tool. All secondary students should know how to use and interpret the information found in a dictionary. The following is a brief list of activities that may be used as a review and/or as an informal diagnostic instrument.

### C. DICTIONARY USAGE

1. **Alphabetizing.** In each series below, number the words in the order in which you would find them in the dictionary.

*Sample*

___ gouge	___ placate	___ mansion	___ realist
___ fabulous	___ piston	___ needle	___ scribe
___ gossip	___ pitiful	___ pedestal	___ tension

2. **Using Guide Words.** The top of each dictionary page contains two "guide words" (these are the first and last entries on that page). Guide words are to help you to rapidly determine if the word you are looking up is found on a particular page. You must decide if alphabetically your word falls between the two guide words. Underline the word(s) in Column B which would be on the page indicated by the guide words in Column A.

*Column A*

come – command  
frank – free  
spread – sputnik

*Column B*

comedy	companion	comfort
fret	freckle	fraud
sprout	squat	sport

3. **Determining Derivation.** Determine the derivation of each of the following words by reading the information between the brackets in the dictionary entry for that word.

radius	indent	erg
perimeter	parenthesis	laser
quadratic	prefix	colloid

4. **Locating Accents.** Use the dictionary to note the syllable(s) accented in the following words. Note that some may have two accented syllables – a heavier or primary accent and the lighter or secondary accent.

investment	interrogatory	streptococcus	reclamation
binomial	correspondence	insoluble	unconsitutional
factorable	homily	protoplasm	indemnity

Use the dictionary to divide the words into syllables, note vowel sound of each accented syllable as shown by the dictionary, and note which, if any, of the syllables contain the *schwa* sound (ə).

5. **Finding Forms.** Write the form of each of the following words which would be the form used to find it in the dictionary.

rectangles	arguing	fumigating	savageness
retailed	modifier	sterilizing	wharves
companies	synopses	exhalation	oases

6. **Determining Meanings.** Determine the appropriate meaning from the dictionary that fits the context in which the word is used in a textbook. Direct the student to use his textbook to see how the word is used or give him sentences which include the word.

7. **Discovering Usage.** Have the students use the dictionary to see if the word has a usage other than in the subject you are teaching. Alert them to such labels as slang, colloquialisms, observations, law and mathematics.

8. **Abbreviating.** Discuss with the students the meanings of the abbreviations *n.*, *v.*, *adj.*, *adv.*, *pron.*, *prep.*, *conj.*, *interj.* Note the usage of a new word from the context in order to select the appropriate meaning. Also have your students study words in your subject, noting the form and meaning when more than one of the abbreviations are used.

D. **RATE.** Rate is an important consideration in reading efficiency. There is much controversy concerning efficient and maximum reading speeds, but it can generally be stated that a high school student under 150 words per minute is an inefficient, word-by-word reader and that a rate over 800 words per minute is skimming.

A student must be taught to adjust his rate of reading to the content of the material being read and to the purpose for reading the material. Teachers should clearly state the purpose for the reading so the students can adjust accordingly.

Silent reading is very different from oral reading. It is not reading without saying the words out loud. The efficient silent reader reads thoughts and ideas, rather than individual words. Looking at and pronouncing individual words is unnecessary and slows down what could otherwise be a more rapid, efficient rate.

Several reasons for students being slow readers are:

1. **Vocalization.** This problem can usually be eliminated with a simple explanation, frequent reminders and a change of habit. Having the student hold something between his lips while reading will make him aware of his problem and help him correct it. Removal of strain and tension will also help.

2. **Eye Movements.** Drill to reduce the number of fixations per line and material to develop steady reading usually helps this problem. As speed and ability increase, faulty eye habits due to too difficult material may disappear.

3. **Word Reading.** Drills with phrase cards and the tachistoscope usually remedy this hindrance.

# 4 Evaluation

The following examples of evaluation techniques may provide ideas for your own management of evaluation.

## A. CHARACTERISTICS OF A GOOD READING LESSON

1. Teacher has a definite goal or purpose for lesson and that purpose is evident to students.
2. Lesson is planned and systematic, yet flexible according to dynamics of classroom situation.
3. Classroom atmosphere is a pleasant, attractive and optimistic one.
4. Attention is paid to individual differences.
5. Rapport between teachers and students is evident.
6. Teacher is diagnosing as she is teaching.
7. There is readiness for the lesson.
8. Pupils are motivated.
9. Materials are varied (basals, library books, workbooks, kits, mimeographed materials, etc.).
10. Full use is made of audiovisual aids.
11. Questions are varied to check different levels of comprehension.
12. Material is at appropriate level for students.
13. Teacher is obviously aware of such levels as "instructional," "independent" and "frustration."
14. Meaningful oral reading activities are used to check comprehension.
15. Pupils have been reained in self-direction (i.e., go from one activity to another without disturbing teacher).
16. All children are productively involved with some aspect of reading.
17. Use is made of classroom and school libraries.
18. There is application of basic reading skills to content areas.
19. Efficient record keeping is done by teacher and students.
20. Teacher has sense of perspective and humor.
21. There is evidence of review and relationship to previously learned material.

22. There are follow-up or enrichment activities.

**B. TEACHING READING IN A HETEROGENEOUS CLASS USING ONE BOOK.** The following was developed by Keith Larson and Sharon Stump, LaFollette High School, Madison, Wisconsin, for *The Adventures of Huckleberry Finn*.

Evaluation of a student's reading achievement will consist of analyzing a student's reading achievement and of analyzing student commentary in all interactions. Three feedback sources will be used: (1) student self-evaluation, (2) instructor's evaluations and (3) students' evaluation of classmates.

1. **Student Self-Evaluation.** Each week the student will provide written commentary in reaction to each of these items:

- (1) To read regularly *The Adventures of Huckleberry Finn* and related essays and stories. This week I have read:

\_\_\_\_\_ **HUCK FINN** \_\_\_\_\_ page \_\_\_\_\_ to page \_\_\_\_\_  
\_\_\_\_\_ page \_\_\_\_\_ to page \_\_\_\_\_  
\_\_\_\_\_ page \_\_\_\_\_ to page \_\_\_\_\_

- (2) To take notes on filmstrips, films and story questions in a manner which will help me learn about life and literature. This week the most significant thing(s) I learned from these sources was \_\_\_\_\_ .
- (3) To raise questions on what I hear in lectures, discussions, filmstrips and on what I read. This week the most significant questions I raised were \_\_\_\_\_ .
- (4) To discuss verbally or in writing my feelings or my understandings of what I see, hear and read. This week my most significant class discussion or writing dealt with \_\_\_\_\_ .
- (5) If I were to grade my overall learning this week, I would give myself a (an) A, B, C, D; Incomplete.

2. **Instructor's Evaluation.** The instructor will evaluate continuously, by mental notation or anecdotal recording, the reading achievement of students. During the week he will observe each student's work at least three times. He will make either oral or written comments to each student at least three times per week.

3. **Peer Evaluation.** Each student will evaluate another student's writing and speaking at least twice every week, using the appropriate evaluation forms.

**C. POETRY.** Basic objectives for this unit are to enable each student:

1. To read poetry with greater understanding.

2. To read poetry with greater enjoyment.
3. To have some knowledge of the structure of poetry.
4. To appreciate the complex role words and form play in expression.
5. To appreciate the difficulty of composing poetry.

The unit is conducted for the whole class and covers all of the topics and skills listed below with the exception of the Japanese forms, haiku and cinquain, and some work on sensory imagery. After the fundamentals are covered, each student has the choice of continuing with poetry in more depth, including the topics mentioned above, or moving to some other area of work.

---

*C – Commendable*                      *S – Satisfactory*                      *N – Needs Improvement*

---

POETRY	Can Recognize			Can Interpret Other			Can Compose Own		
	<i>C</i>	<i>S</i>	<i>N</i>	<i>C</i>	<i>S</i>	<i>N</i>	<i>C</i>	<i>S</i>	<i>N</i>
I. Elements of Poetry									
A. Rhythm	<input type="checkbox"/>	<input type="checkbox"/>	<input type="checkbox"/>	<input type="checkbox"/>	<input type="checkbox"/>	<input type="checkbox"/>	<input type="checkbox"/>	<input type="checkbox"/>	<input type="checkbox"/>
B. Rhyme	<input type="checkbox"/>	<input type="checkbox"/>	<input type="checkbox"/>	<input type="checkbox"/>	<input type="checkbox"/>	<input type="checkbox"/>	<input type="checkbox"/>	<input type="checkbox"/>	<input type="checkbox"/>
C. Figures of Speech									
1. Metaphor	<input type="checkbox"/>	<input type="checkbox"/>	<input type="checkbox"/>	<input type="checkbox"/>	<input type="checkbox"/>	<input type="checkbox"/>	<input type="checkbox"/>	<input type="checkbox"/>	<input type="checkbox"/>
2. Simile	<input type="checkbox"/>	<input type="checkbox"/>	<input type="checkbox"/>	<input type="checkbox"/>	<input type="checkbox"/>	<input type="checkbox"/>	<input type="checkbox"/>	<input type="checkbox"/>	<input type="checkbox"/>
D. Sensory imagery	<input type="checkbox"/>	<input type="checkbox"/>	<input type="checkbox"/>	<input type="checkbox"/>	<input type="checkbox"/>	<input type="checkbox"/>	<input type="checkbox"/>	<input type="checkbox"/>	<input type="checkbox"/>
E. Forms	<input type="checkbox"/>	<input type="checkbox"/>	<input type="checkbox"/>	<input type="checkbox"/>	<input type="checkbox"/>	<input type="checkbox"/>	<input type="checkbox"/>	<input type="checkbox"/>	<input type="checkbox"/>
II. Types of Poetry									
A. Narrative	<input type="checkbox"/>	<input type="checkbox"/>	<input type="checkbox"/>	<input type="checkbox"/>	<input type="checkbox"/>	<input type="checkbox"/>	<input type="checkbox"/>	<input type="checkbox"/>	<input type="checkbox"/>
B. Descriptive	<input type="checkbox"/>	<input type="checkbox"/>	<input type="checkbox"/>	<input type="checkbox"/>	<input type="checkbox"/>	<input type="checkbox"/>	<input type="checkbox"/>	<input type="checkbox"/>	<input type="checkbox"/>
C. Personal	<input type="checkbox"/>	<input type="checkbox"/>	<input type="checkbox"/>	<input type="checkbox"/>	<input type="checkbox"/>	<input type="checkbox"/>	<input type="checkbox"/>	<input type="checkbox"/>	<input type="checkbox"/>
D. Other (haiku and cinquain)	<input type="checkbox"/>	<input type="checkbox"/>	<input type="checkbox"/>	<input type="checkbox"/>	<input type="checkbox"/>	<input type="checkbox"/>	<input type="checkbox"/>	<input type="checkbox"/>	<input type="checkbox"/>
III. Reading				<i>C</i>	<i>S</i>	<i>N</i>			
A. Can read poetry orally with expression according to meaning				<input type="checkbox"/>	<input type="checkbox"/>	<input type="checkbox"/>			

- |  | <i>C</i>                 | <i>S</i>                 | <i>N</i>                 |
|--|--------------------------|--------------------------|--------------------------|
| B. Can interpret meaning in poetry                                 | <input type="checkbox"/> | <input type="checkbox"/> | <input type="checkbox"/> |
| <b>IV. Speaking</b>  |                          |                          |                          |
| A. Contributes verbally to class discussions                       | <input type="checkbox"/> | <input type="checkbox"/> | <input type="checkbox"/> |
| B. Expresses ideas clearly   | <input type="checkbox"/> | <input type="checkbox"/> | <input type="checkbox"/> |
| V. Creativity (if applicable)                                      | <input type="checkbox"/> | <input type="checkbox"/> | <input type="checkbox"/> |
| <b>VI. Behavioral Emphases (for this unit and class structure)</b> |                          |                          |                          |
| A. Participates in exchange of ideas                               | <input type="checkbox"/> | <input type="checkbox"/> | <input type="checkbox"/> |
| B. Listens to others (including teacher)                           | <input type="checkbox"/> | <input type="checkbox"/> | <input type="checkbox"/> |
| C. Completes daily assignments                                     | <input type="checkbox"/> | <input type="checkbox"/> | <input type="checkbox"/> |

Spelling and Writing Patterns – Work in this area was continued for all students along with the unit work in poetry.

- |                                  |                          |                          |                          |
|----------------------------------|--------------------------|--------------------------|--------------------------|
| I. Recognizes Word Patterns      | <input type="checkbox"/> | <input type="checkbox"/> | <input type="checkbox"/> |
| II. Recognizes Sentence Patterns | <input type="checkbox"/> | <input type="checkbox"/> | <input type="checkbox"/> |
| III. Spelling Tests              | <input type="checkbox"/> | <input type="checkbox"/> | <input type="checkbox"/> |

Teacher's Comments:

Parent's Comments:

**D. LESSON ANALYSIS**

**WORKSHEET**

Date: \_\_\_\_\_ Class: \_\_\_\_\_

worst

possible \_\_\_\_\_ perfect lesson  
0 1 2 3 4 5 6 7 8 9 10  
lesson

What factors contributed to your rating this lesson as high as you did?

What would you have to do to make it a perfect lesson?

Contract with yourself about something you'll do next time.

**E. READING CONTRACT**

Student's Name \_\_\_\_\_

Name of Book \_\_\_\_\_

Author of Book \_\_\_\_\_

When I have finished reading this book, I plan the following project to help me understand and remember the story:

\_\_\_\_\_  
\_\_\_\_\_

I will try to do my best work on this contract.

Signed \_\_\_\_\_

-----

Date contract completed: \_\_\_\_\_

Teacher's comment: \_\_\_\_\_

\_\_\_\_\_  
\_\_\_\_\_

Name \_\_\_\_\_

DAY	DATE	ACTIVITY	STUDENT COMMENTS	TEACHER COMMENTS
MONDAY				
TUESDAY				
WEDNESDAY				
THURSDAY				
FRIDAY				



## SELECTED REFERENCES

- Aukerman, Robert C. *Reading in the Secondary School Classroom*. New York: McGraw Hill, 1972, pp. 137-162.
- Burron, Arnold, and Claybaugh, Amos L. *Using Reading to Teach Subject Matter*. Columbus, Ohio: Charles E. Merrill Co., 1974.
- Deighton, L. C. *Vocabulary Development in the Classroom*. New York: Teachers' College Press, 1959.
- Hafner, Lawrence E. *Improving Reading in the Middle and Secondary Schools*. New York: MacMillan Publishing Co., Inc., 1974, pp. 346-373.
- Herber, Harold L. *Teaching Reading in Content Areas*. Englewood Cliffs, N.J.: Prentice Hall, Inc., 1970, pp. 219-230.
- Karlin, Robert. *Teaching Reading in High School*. 2nd Ed. Indianapolis: Bobbs-Merrill Co., 1972, pp. 219-235, 332, 336, 345-346.
- Laffey, James L. *Reading in the Content Areas*. Newark, Dela.: International Reading Association, 1972.
- Meade, Richard A., and Small, Robert C., Jr. *Literature for Adolescents: Selection and Use*. Columbus, Ohio: Charles E. Merrill Publishing Co., 1973, pp. 50-79, 291-304.
- Shepherd, David L. *Comprehensive High School Reading Methods*. Columbus, Ohio: Charles E. Merrill Publishing Co., 1973, pp. 169-186.
- Smith, Richard J., and Barrett, Thomas C. *Teaching Reading in the Middle Grades*. Reading, Mass.: Addison-Wesley Publishing Co., 1974.
- Strang, Ruth; McCullough, Constance M.; and Traxler, Arthur. *The Improvement of Reading*. 4th Ed. New York: McGraw Hill, 1967, pp. 73-74, 300-320.
- Thomas, Ellen Lamar, and Robinson, H. Alan. *Improving Reading in Every Class*. Boston: Allyn and Bacon, Inc., 1972, pp. 5, 9-44, 45-46, 69-104, 118-123, 124-133, 135-165, 167-204.
- Vaughan, Joseph L. Jr.; Estes, Thomas H.; and Curtis, Sherry L. "Developing Conceptual Awareness in the English Classroom," (in press), 1974 (Available by writing J. L. Vaughan, Department of Education, University of Arizona, Tucson.).

# 15 Teaching Techniques

- A. **GLOSSING.** Students reading passages from the social studies textbooks often react passively or understand the meaning partially or not at all. Instinctively, many content area teachers will read short passages from the text and then stop to describe an experience, a hidden meaning or a subtle interrelationship. They might then give an explanation for a concept or interject a humorous situation to instill clarity and meaning. According to Edward Fry in *Reading Instruction for Classroom and Clinic*, this type of reading with its emphasis on meaning has been used since the Middle Ages and is called "glossing."

This method can be utilized by the social studies teacher with a great variety of reading materials. When the teacher is reading aloud from the textbook, the students should follow in their textbooks. This helps students to understand stress, voice intonation and the use of phrasing in reading. It also might help the student in pronunciation and in interpretation and determination of meaning. This technique can be part of the motivation necessary to the involvement of students in a lesson or assignment.

This method, "glossing," depends upon the skill of the social studies teacher to make the printed word come alive. The ability of a teacher to draw upon personal background and educational experience, and ability to present oral reading will separate the stimulating teacher from the boring one.

- B. **SPECIALIZED SKILLS IN THE SOCIAL STUDIES.** Students become more independent in the study of social studies through the acquisition of specific reading/study skills. Although the common study skills outlined in the study skill section are important, there are certain additional specific skills that are peculiar to social studies that should be further examined: These specific skills adapt to social studies because of the author's organization and presentation of material and because of the types of narrative accounts that one featured in social studies. Specific skill patterns for the social studies content area include: propaganda; sequential events with dates; illustrations, maps and graphs; detailed statements of fact; cause and effect; comparison and contrast; facts versus opinions and assumptions, and appreciation of time and space concepts.
- C. **CLOZE TECHNIQUE.** The cloze technique is a type of completion test that may ask for a recall answer but uses the context to the maximum in obtaining a specific or general response usually within the sentence instead of at the end. This technique, used chiefly for testing and assessing the readability of a textbook, can be used by social studies teachers for meaning drill.

The cloze technique is easy for the social studies teacher to construct and score, and it measures the students' knowledge of grammatical patterns, spelling and recall with context clues. A teacher can design materials for use with the cloze technique by selecting passages from the textbook and duplicating them, leaving blank every 10th word or *n*th word. The teacher can devise the pattern to suit his purpose, leaving out only the nouns, verbs or specific vocabulary. Other variations of this technique might include timed

exercises, additional credit for the student or student constructed passages. The following cloze exercise is a brief program to measure specific vocabulary-contextual meanings of the selection.

The \_\_\_\_\_ government should encourage the development of home \_\_\_\_\_. In December, 1791, Hamilton sent to the House of \_\_\_\_\_ a "Report on Manufactures." In it he \_\_\_\_\_ that the federal \_\_\_\_\_ should encourage home industries. He maintained that \_\_\_\_\_ in industry would make the country more \_\_\_\_\_, since capital applied to manufactures often yielded a higher \_\_\_\_\_ than capital in agriculture. The increases of industry would also encourage the immigration of skilled \_\_\_\_\_. Factories could put idle women and \_\_\_\_\_ to production work. \_\_\_\_\_ further argued that the \_\_\_\_\_ would neither be truly independent or safe in \_\_\_\_\_ until it ceased to depend on \_\_\_\_\_ for many essential goods.

- D. **MODELS OF SOCIAL STUDIES LESSONS.** The following is a model of a lesson plan that can be used by social studies teachers concerned about specific reading lessons. Ideas or suggestions gained from it could be incorporated into their own lesson pattern of reading assignments. Additional patterns concerning lessons or assignments will follow in outline or annotated form.

1. **Lesson Pattern**

Preparation	Reading	Response
pretest	silent reading	discussion
preview		rereading
purpose		reading skills transfer

- (1) **Pretest.** A pretest of the unit may take different forms, but the major purpose is to determine the achievement level of the class on a particular unit. The form of the pretest may be objective or essay type questions, vocabulary test, cloze test for contextual vocabulary meaning or a test of concept understanding. A pretest would enable the teacher to assess both the reading difficulty of the material and the individual student achievement within the unit. Pretests can help the teacher and student plan the unit according to what reading skills need the most emphasis. Pretests have other uses for the social studies teacher. For example, the amount of vocabulary and comprehension gained by the students can be assessed by comparing it with a post-test over the same material. The types of audiovisual aids or graphic aids needed can also be ascertained by pretest along with how much time needs to be allotted to the unit; whether study guides need to be provided for the class, and how much motivation or a background readiness must be presented.

- (2) **Preview.** Previewing a unit includes developing motivation, background and vocabulary. Previewing determines the organizational qualities of the unit such as depth and scope of the material, the author's sequences of main ideas, various illustrations, new vocabulary and terms, number of pages to be covered, the number of new concepts, interrelationship of personal experience to the topics in the unit and any other mechanical aids needed to build interest in the unit. Of course, the teacher is the catalyst in developing motivation and generating enthusiasm in students.

Discussions could be centered around the results of the pretest, mechanical organization and students' experience or knowledge related to the unit. The teacher's professional experience and knowledge of the unit, including personal experience, supplemental materials and the development of background through carefully selected graphic aids, could be employed.

Vocabulary development is an important part of the pretest and preview skills. The pronunciation and meaning of words, as indicated on the pretest, should be introduced in contextual settings by the teacher. This is usually done orally first, and then visually through the use of phrases, sentences and graphic aids.

Graphic aids will help the social studies teacher to present background and vocabulary skills in a stimulating and easily understood manner. The graphic aids include maps, tables, concrete objects, charts, diagrams, pictures, time tables, filmstrips, bulletin boards and chalkboards.

- (3) **Purposes.** Social studies is a problem-solving science, and setting purposes for reading is the key in creating a problem-solving situation. The purpose of the assignment determines the quality of the reading desired, and the length of the assignment determines the quantity of what is to be read. The amount of time needed for this step depends upon the background of the class, length and difficulty of the material and the purposes to be emphasized. This aspect is crucial to the development of meaning or comprehension skills. Purposes could center around such social studies patterns as cause and effect, propaganda, comparison and contrast, sequential events with dates, statements of fact or the use of graphic material.

Students at the secondary level should receive training in setting purposes for reading. This does not mean that the content teacher would not include student selected purposes, but it would also involve students in the dynamics of purpose-setting skills. Students who are involved in setting purposes will be more motivated, more apt to complete the assignment and have a greater desire to read beyond the assignment. The ultimate goal of independent reading is to get students to automatically set purpose and become mature readers.

- (4) **Silent Reading.** Most of the silent reading may be done outside the classroom, but certain reading assignments are best completed within the classroom. Within the classroom the teacher can assist students with vocabulary development, study skills and any individual help that the student might need. Students who cannot read independently need the social studies teacher to guide and help them through the reading assignment. This aids the student in applying other learning techniques to the subject.

- (5) **Discussion.** This is not just a testing period to see whether students can answer the purposes set in the beginning of the lesson, but also includes a recitation period for the clarification of concepts, the locations and explanation of new vocabulary terms, the analyzation of meaning-getting skills and the discussion of study skills for further problem-solving ability. The different types of questions asked by the teacher can either make this part a testing session or a discussion period. It is imperative that the purposes be discussed. Otherwise, in the next lesson, students might have a tendency to ignore purposes. The discussion may raise new questions about the clarification of purposes or concepts, causing rereading of parts of the assignment.
- (6) **Rereading.** Rereading may be done either orally or silently, but only on selected parts. When the policy is to reread the entire selection, the student will not concentrate enough on the first reading. Reasons for rereading may evolve from the discussion for clarifying concepts, setting new purposes, developing skills, extending purposes or transferring activities.
- (7) **Skills and Drills.** This is the part of the lesson where the teacher determines what skills need additional teaching and practice. This could be any reading skill, but usually consists of vocabulary, meaning type questions and study skills needed to handle the material in future lessons. Duplicated sheets are often used to reinforce and build skills presented in the lesson. Portions of a study guide might be utilized for individual students, or commercially prepared material may provide the skill review necessary for the student. The teacher must diagnose the skills of the class, and present teaching techniques to eliminate the difficulty of reading skills.
- (8) **Transfer.** This is the application part of the lesson to perform one or more of a variety of follow-up activities. This practice will extend the students' knowledge and opportunity to work independently or in small groups.

Creative activities include art activities, creative writing and dramatization. Study activities include commercially prepared material, teacher-made material, such as study guides or duplicated work sheets, and student projects of organizing information from the lesson into charts, tables, time lines, facts and opinions. Research activities include extended reading on related topics, locating additional information about previous topics, doing committee work toward a new topic and applying the skills learned in the lesson.

The social studies teacher cannot assume that the transfer of reading skills will automatically be made from one topic to another. New problem-solving situations should be devised by the teacher to guarantee that the reading skills are employed. All follow-up activities should be evaluated upon completion by both the teacher and student.

- E. **A READING ASSIGNMENT OUTLINE.** The following reading assignment outline is presented by Robert L. Aukerman in his book *Reading in the Secondary Classroom*, (New York: McGraw Hill Book Co., 1972) pp. 105-106. It is presented in this section with the permission of McGraw Hill Book Co. as one of the most complete outlines that

could be used effectively by the social studies teacher.

1. Preparation for reading the assignment.
    - a. Review what has gone before.
    - b. Relate this to what is coming.
    - c. Preview what is coming.
    - d. Discuss what the students know.
    - e. Relate this to what is coming.
    - f. Elicit questions related to content.
    - g. If their questions are not adequate, then provide a question to answer.
  2. Vocabulary and development of concepts.
    - a. Discuss concepts that need clarification.
    - b. Present vocabulary in context (not in isolation).
    - c. Relate general and specific word meanings to context.
  3. The purpose of reading.
    - a. Read to answer a question.
    - b. Tailor the question to the group.
    - c. When necessary, fit the question to an individual.
    - d. Pose problems when appropriate.
    - e. Read for more than one solution.
  4. Discussion after reading.
    - a. Use the purposes of the reading as a point of departure.
    - b. Challenge the students to probe below the surface facts.
    - c. Seek influence.
    - d. Draw tentative conclusions.
    - e. Elicit alternative solutions.
  5. Aftermath.
    - a. When facts or interpretations are contested, follow through with more reading.
    - b. Skim for the gist.
    - c. Scan for specific information.
    - d. On occasion, read aloud from the text.
    - e. Follow-up with readings from other sources.
- F. **SQ3R or SQ4R STUDY TECHNIQUES.** One technique used to study an assignment is the SQ3R method by Robinson. An outline of this method is found in the study skill section. There are many modifications of the SQ3R method, and one is the SQ4R by Lyle L. Miller. The following is a description of the SQ4R method as stated in Miller's workbook *Increasing Reading Efficiency*, (New York: Holt, Rinehart and Winston, Inc., 1964) p. 19.

The SQ4R Method of Study:

1. **Survey.** Glance over the headings in the chapter to see the few big points which will be developed. This survey should take only a few seconds and will show the several core ideas around which the discussion will be developed.
2. **Question.** Turn the first heading into a question. This will arouse your curiosity and

thus aid comprehension. It will help to bring to mind information that you already know. In this way your understanding of that section will be increased. The question will make the important points stand out.

3. **Read.** Read to answer the question. Make this an active search for the answer. You will find that your eyes tend to move more rapidly over the material, slighting the unimportant or explanatory details while noting the important points.

4. **Recite.** Try to recite the answer to your question without looking at the book. Use your own words and think of an example. If you can do this you know what is in the book; if you can't, glance over the section again. If you jot down cue phrases in outline form as you do this, you will have an excellent basis for later review and study.

5. **Repeat.** Repeat Steps 2, 3 and 4 on each succeeding section. Turn the next heading into a question, read to answer that question and recite the answer by jotting down cue phrases in an outline. Read in this way until the lesson is completed.

6. **Review.** Look over your notes to get a bird's eye view of the points and their relationships. Check your memory as to the content by reciting the major subpoints under each heading. This checking of your memory can be done by covering up the notes and trying to recall the main points, then exposing each major point and trying to recall the subpoints listed under it.

## G. STUDY GUIDES

1. **Purpose.** There are four major purposes of the study guide. First, it provides practice and guidance in reading skills needed by students to understand the unit. Second, it provides a range of reading-meaning skills to be adopted for individual differences, and third, it is an outline of information for use in follow-up discussion. Finally, it is a source for students to become independent readers.

2. **Preparation.** A study guide is only necessary if the students are unable to read independently. This means the teacher must know the reading potential of the class. This could be through the informal reading inventory discussed in the section on prescriptive techniques (Section II) or through a fast compilation of a scattergram could be helpful when the IQ and reading achievement scores of the student are available. The following is an example of such a scattergram based on median class achievement and median class IQ level.

# SCATTERGRAM:

Class Median IQ

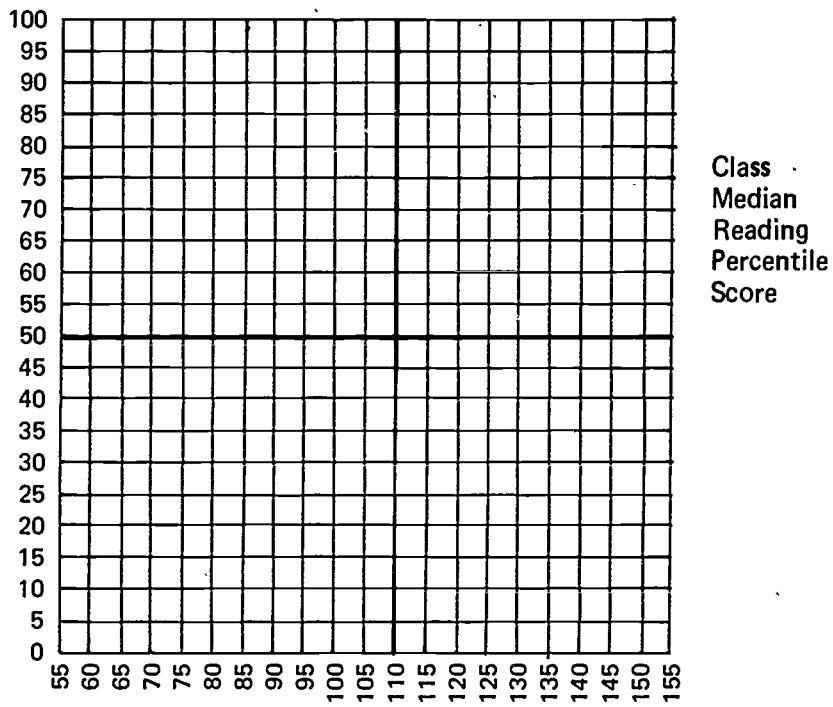



The teacher must then determine what concepts are to be derived from the material, what specific skills need to be understood, and what level of understanding is desired to decide if a study guide is the instrument best suited for assisting the student.

The guide should start at the most accurate level of understanding so the student can work independently. This guide should be so programmed that the student could move from the simple to the complex. The guide would be like the inductive thinking process. The teacher would guide the class as in a discussion from a low level concept to a higher level concept.

### 3. Utilization Suggestions

- (1) Study guides should be used with students to strengthen their understanding of the material.
- (2) Study guides should be presented to students after the teacher has taught the essential reading skills. They are not initial teaching devices, but reinforcing skills and drills.
- (3) Study guides can be used in or out of the classroom structure.
- (4) Study guides can be used in grouping procedures. Guides of different levels aid in recognizing and providing for individual differences.
- (5) Study guides help students in the organization of their notebook.
- (6) Study guides are designed to stimulate exploration and discussion. There may be a few exact answers, but students are encouraged to participate in the thinking process.
- (7) Study guide objectives should be understood by the student. Objectives should be specific, reasonable and important to the student.

# 6 Understanding Social Studies Materials

- A. **VOCABULARY.** Specific and general vocabulary are the core in obtaining meaning-getting information. If the vocabulary is strange to the student at a ratio of 10 familiar to 100 unfamiliar words, the material can be frustrating. An adaptive vocabulary program may be necessary or greater amounts of time may be required to build background and concept development. The teacher might have to use more audiovisual aids. If the reading material is difficult, the teacher will have to provide more guidance enabling students to select purposes. A starter list of social studies terms follows.

abbreviations	details	opinions
actions	diagrams	organization
allusions	directions	paragraph
assumptions	effects	photograph
attitudes	events	pictures
author's attitude	examples	point of view
author's purpose	facts	problems
cartoons	graphs	propaganda
causes	ideas	results
charts	illustrations	scales
conclusions	imagery	sentences
connotations	implications	setting
consequences	main idea	symbols
denotations	maps	tables
descriptions	mood	time and space
		trends

This list is not all inclusive.

- B. **LEVELS OF COMPREHENSION.** Reading authors have divided meaning-getting skills into many levels of understanding. The categories or levels may not be as important as the successful attempts by content teachers to provide a range or variety of questions that would cover levels of meaning. Meaning levels are sometimes grouped as literal, interpretive and critical.

The literal level is the skill of getting the direct meaning of a word, concept or group of words. The content teacher uses the literal meaning level for many purposes to direct details, to locate topic sentences, to scan for specific words or phrases and to determine sequences of events. Many teachers never get beyond this level of meaning because it is easier to teach than higher levels of meaning. Interpretive levels are built not only upon the literal level, but also upon a higher degree of thinking and reading skills.

Various purposes of meaning used at the interpretive level are cause and effect questions, inferences and generalizations, comparisons, implied details and conclusions. Students need direct instruction on this meaning level. This level is often more difficult to measure than the literal level, and it is definitely more time consuming. Class discussion using the various meaning purposes at this level can be very helpful to the student.

The critical level is based upon the successful understanding of the first two levels, allowing the student to evaluate and judge the information. The various meaning purposes at this level are: fact versus assumption or opinion, bias or fairness of the author in presenting the material, agreement with other authors and propagandist techniques employed.

Content teachers can also group meaning levels as recall, interpretation and application. The various purposes set by the teacher determine the level of understanding the students need for the content. Recall is probably the easiest to learn by students, but also the easiest to forget. This recall level extends from the concrete to the abstract. Definitely, there are occasions when recall of facts and details is essential to the content materials.

Interpretive level of meaning requires the students to go beyond the recall level, analyzing the purposes of the author and asking questions concerning cause and effect, etc.

C. **OUTLINE OF COMPREHENSION SKILLS.** Application of meaning skills is very important in the content areas. Students may be able to recall and interpret ideas and yet not be able to apply the information in a problem-solving situation. The following list of meaning-getting skills should be examined so that the instruction or reading for various purposes will cover a wide range of meaning levels:

1. Learning to follow directions.
2. Perceiving main ideas.
3. Learning to select supportive details.
4. Interpreting verbal connotations and denotations.
5. Interpreting the organization.
6. Anticipating outcomes.
7. Reorganizing and understanding the writer's purpose.
8. Identifying the antecedents of such words as *who, some, they* or *it*.
9. Interpreting figurative expressions.
10. Making inferences and drawing conclusions.
11. Retaining ideas.
12. Identifying elements of style.
13. Identifying and evaluating character traits.
14. Generalizing.
15. Making judgments.

16. Comparing and contrasting.
17. Perceiving relationships: cause-effect, general, specific, sequence, size, place and time.
18. Recognizing story problem or plot structure.
19. Learning to handle indirect details.
20. Identifying and evaluating character traits.
21. Summarizing and organizing ideas for the purpose of retention.
22. Identifying the tone, mood and intent of purpose of the author.
23. Giving meaning to phrases, sentences and paragraphs.
24. Reacting to sensory images.
25. Recognizing emotive language.

## SELECTED REFERENCES

- Adams, W. Royce. *How to Read the Social Science*. Glenview, Ill.: Scott, Foresman and Co., 1970.
- Aukerman, Robert C. *Reading in the Secondary School Classroom*. New York: McGraw-Hill Book Co., 1972.
- Miller, Lyle L. *Increasing Reading Efficiency*. New York: Holt, Rinehart and Winston, Inc., 1964.
- Shepherd, David L. *Comprehensive High School Reading Methods*. Columbus, Ohio: Charles E. Merrill Publishing Co., 1973.

# 17 Location Skills in Science Reading

The section on science reading consists of three parts: reading skills, teaching ideas and resource materials. How does the successful student handle the reading requirements of the science class? The answer to this first question is based on skills or competencies necessary for scientific reading. What can the teacher do to increase students' success and independence in scientific reading? The answer to the second question suggests a number of teaching ideas and techniques which the teacher may find helpful. Where can we locate some relatively easy scientific material that students *can* read and *will* read? The last question is addressed by listing a number of printed resources for poor readers in science.

A. **LOCATING INFORMATION.** If your goal is to help students locate information, you may wish to:

1. Find out how well your students locate information in content texts and pamphlets, libraries and other information sources. You can use this knowledge to implement suggestions on an individualized diagnostic/prescriptive basis.

2. Make it an ironclad rule to discuss with your students the title, authors, publisher, copyright, table of contents, glossary, index and other significant features of content texts the first time the students receive the texts or on any other occasion when it seems appropriate.

3. Several times each week ask your students to locate some point of information in their text material. Then discuss which feature(s) of the text they have utilized and how they might improve their efficiency.

4. Conduct "treasure hunts" for information using content texts, libraries and other information sources.

5. Make regular assignments, e.g., research papers and reports, that require the students to use information sources. However, before they begin their search be sure they know *where* the sources can be found and *what* information they contain. A small amount of time expended in explanation and direction can result in significantly greater science mastery. For example, the instructional unit on the *Readers' Guide to Periodical Literature* can be useful in your classroom. It may also serve as a model for constructing other units on other topics, e.g. using the glossary, using the card catalog, using drug companies' catalogs and reading science magazines.

B. **USING THE "READERS' GUIDE TO PERIODICAL LITERATURE."** The following is reproduced by permission of Dr. Estella Reed.

TO THE TEACHER:

*Behavioral Objectives:*

1. The user will be able to identify titles of magazine articles on topics of interest in the

*Readers' Guide.* He will be able to further identify the author, name of the magazine carrying the article, the issue date of the magazine and the pages where the article is printed.

2. The user will be able to gather the existing magazine material, read it, evaluate it and make notes of the contents.

3. The user will be able to draw conclusions about the arrangement of complex entries, i.e., "United States."

*Equipment for Test:*

The learner will need a test sheet, a pencil and four bibliography cards or 3" x 5" slips of white paper.

*Time:*

Untimed. The *speed* of locating material is unimportant while the process is being studied. The test can be extended to several sessions.

*Teacher Options:*

Supply the directions for using the *Readers' Guide to Periodical Literature* if the learner does not complete the proficiency test satisfactorily, or, since the goal is skill development, provide the student with directions at the same time he is taking the test.

The proficiency test can be readministered by striking out several of the given topics and by inserting new topics that are in accord with the teaching units of current lessons in the classroom.

The directions for using the *Readers' Guide to Periodical Literature* may best be used by paired learners. The proficiency test is individual work.

PROFICIENCY TEST:

Test No.

Name \_\_\_\_\_ Grade \_\_\_\_\_ Date \_\_\_\_\_

1  
2  
3  
4  
5

1. Check two topics you are interested in learning more about:

*Topics*

*Questions*

- Washington, D.C.
- ice skating
- the brain
- heart transplant
- the metric system
- space travel

2. Write one question for each of the two topics you have checked above. Write in the space under Questions.

3. Go to the *Readers' Guide* and do the following steps:
  - a. Skim the articles under the topic you have chosen.
  - b. Be selective in choosing an article that will probably help in answering the question you have written above.
  - c. Copy the name of the magazine and all the information that follows it. Use a separate card for each magazine reference.
  - d. Find the article in the specific magazine.
  - e. Read the article to determine whether or not it helps answer your question. If it is not helpful, write "no" on your card and choose another article.
  - f. Write notes about the article on your card. Copy any sentence (and put it in quotation marks) that answers your original question.
  - g. On any card that you expect to use in a bibliography, copy the author's last name, his first name and then the exact title of the article. Put this information *above* the name of the magazine. (See Step C above)
  - h. Write the name of the topic (See Item 1 above) you are researching on the top line of the card before showing it to a "checker."
  
4. Look up the topic "United States." Make two generalized statements in the space below about the arrangement of the subtopics under that heading.
  - a.
  - b.

#### DIRECTIONS FOR USING THE READERS' GUIDE:

The *Readers' Guide* is an index to magazine articles. Periodical literature or magazines is writing that is published at regular intervals. The *Readers' Guide* covers magazine material by arranging it under topics which suggest the content of the articles. The *Readers' Guide* should be used when you want to find recent writings or material that is additional to that found in your textbook, filmstrips or tapes. Newspapers also have special indexes, such as the *New York Times Index* or *Facts on File*.

Note that the three key words above are *index*, *magazines* and *recent*. The first letter of those three words could create an acronym which could stand for *I'M* Researching.

#### *The Process:*

1. Look up a topic in *Readers' Guide* alphabetically the same way you find a word in the dictionary.
2. Skim over all the articles that are listed below the topic. Notice that the titles of articles follow the author's name.
3. Choose those articles that seem to be the best leads to the information you actually want.
4. The name of the magazine that contains the article will be listed following the title of the article. You will need to write this information down so that you won't be confused when you go to the magazine room. It is a good practice to use 3" x 5" cards or pieces of paper. Names of magazines are abbreviated. Turn to the first few pages of *Readers' Guide* for full names of magazines.
5. Leaving at least one inch at the top of the card, copy the name of the magazine and all the information that follows it. This is called an entry in the *Readers' Guide*. Put each entry on a separate note card so you can add notes when you read the article.



Note: If the information is confusing to you, look at the sample entry on the first few pages of *Readers' Guide* where a full explanation is given.

6. Check the name of the magazine for each entry you have copied on your note cards against the list of magazines available in the library.
7. See if the library has the specific issue date you need. This will be the last part of the entry you copied from *Readers' Guide* in Step 5.
8. Look at the entry you copied in Step 5. Find the numbers *following* the mark of punctuation called the colon (:). These are the pages you will find the article on. Turn to these pages.

Note: If you are in a library which has the magazines bound into a hard-cover volume, the number *preceding* the colon (:) is the bound volume number. Large libraries bind their magazines for easier handling. The magazine may be on microfilm, and you will read it through a projector.

9. Skim read the article to see whether or not the material is helpful in your information quest. Reject articles that are not helpful.
10. Take notes on any ideas of importance. Write a summary statement.
11. Put quotation marks around any sentences you copy exactly as the article printed them. When you steal exact words from an author and do not give him credit by showing quotation marks, you are guilty of literary theft or *plagiarism*.
12. At the top of the card, just above the name of the magazine, write (1) the author's last name, (2) a comma, (3) his first name and initial and (4) the exact title of the article. Put the title of the article in quotation marks.

Note: Occasionally no author's name is given. In that case, start with the name of the article and put it in quotation marks.

13. For advanced students, if you are writing a research paper, the top left corner of the card should have room to write a symbol that would tell you what section of your outline the card will fit into.

IIIB corresponds to outline for research paper

III B TURTLES – CARE AND FEEDING  
Simpson, James A. "Regularly without fail."  
Ranger Rick 7: 11-12, Ag, 74

14. Advanced students should also know that research papers require a bibliography. A bibliography is a list of references you have used to gather the information. It is usually alphabetized by author. By using a separate card for every source of information, the cards can be arranged in alphabetical order, by author, for the bibliography.

# 18 Skills in Science Vocabulary

A. **PRONOUNCING WORDS.** If your goal is to help students pronounce words, you may wish to:

1. Print polysyllabic science words on the chalkboard, e.g. *deoxyribonucleic acid*, and ask students to help you divide them into syllables. Don't be concerned about doing it "wrong;" your goal is to *approximate* the number of sounds in the word, not to syllabicate the word exactly the way the dictionary does it.
2. With particularly difficult words, ask the entire class to say the word along with you several times. This will reduce the possibility of individual embarrassment while each student acquires an "ear" for the word.
3. Most reading experts agree that even silent reading requires at least "inner" pronunciation. Therefore take every opportunity to focus the students' attention on key words. For example, print an unfamiliar (but important) term on the chalkboard. Ask students to raise their hands when they find the term on a given page in the text material, or print the word and ask students to jot down the *number* of times it appears on a given page. Walk around the classroom to check their answers.
4. Print the most essential terms from a chapter or unit on 3" x 5" cards or similar materials. Print one term per card using flow pen (or have a student do it). Pair students who seem to have difficulty pronouncing words, and have them time and check each other as they pronounce the words as rapidly and accurately as they can.
5. Select words most essential to a chapter or unit. Construct an exercise similar to the following, which was used by a chemistry teacher.

## RAPID RECOGNITION – CHEMISTRY VOCABULARY:

Directions: Look closely at the first word on each line. Find the same word among the four words that follow. Underline this word. On some lines there may not be two words alike. If so, skip the line and continue. See how many seconds it takes you to do this page. The first one is done for you.

cracking	tracking	cracked	<u>cracking</u>	lacking
saturated	saturation	saturn	satiated	saturated
alkane	alkane	alkaline	alike	become
organic	organic	organism	orgiastic	organically
esterification	estuary	ossification	satisfaction	esterification
substitution	constitution	substitution	substituted	absention

hydrocarbon	hydrocarbon	hydroformed	hydropower	hydrocarbon
alkene	alkane	alkene	alkyne	alkaline
aliphatic	elipsed	emphatic	aliphatic	alkylation
isomer	isobar	isomer	isosceles	misnomer
addition	additine	added	addled	adulation
alkyne	alkene	canine	already	alkyne
polymerization	polyunsaturated	polyglot	polynomial	polymerization
fermentation	fertilization	civilization	fermentation	fertilized
alkylation	alkylation	alkyne	allunial	allegory
hydroformed	hydroforming	hydrocarbons	malformed	hydrophobia
saponification	satisfied	saponification	satisfaction	salvation

Time \_\_\_\_\_ seconds

## B. UNDERSTAND THE MEANINGS OF TECHNICAL VOCABULARY

1. Make it an ironclad rule to emphasize new terms by writing them on the chalkboard, explaining and discussing them. There is no magic or best way to help students increase their science vocabulary, except by *constant emphasis*.
2. Discuss the etymology of important scientific vocabulary.
3. Compile a class dictionary of new technical terms important to your curriculum.
4. Encourage students to keep an individual word file of newly mastered technical terms.
5. Give students frequent directed practice in using context clues to apprehend the meaning of technical terms. For example, write on the chalkboard a sentence such as, "Much stress has been placed on *turmidial* effects, that is, on the influence of psychic states on the body and its processes." Ask your students to help you make a list of all possible words that would make sense in place of the nonsense word *turmidial*. Let them support their choices or try to refute others. At some point refer them to a given page in the text material where they can find the appropriate meaning.
6. Remind students frequently that many important scientific words have structure clues which appear over and over again. For example, even though *protoplasm* may be an unfamiliar term, the student may get on the right "track" by recognizing the root meaning of *proto*. A single reading assignment or short unit of study may contain dozens

of examples of structure clues, as in the following exercise constructed by a biology teacher.

### VOCABULARY TOOLS – PREFIXES AND WORD ROOTS:

Directions: For each pair of prefixes or roots below, decide whether the meaning is the same (A), different (D), or neither (N). Then use the first one to form a term used in our study of biology.

<u>  D  </u>	1.	bi	<u>  Bisect  </u>	uni
<u>      </u>	2.	bio	<u>                  </u>	vivo
<u>      </u>	3.	homo	<u>                  </u>	hetero
<u>      </u>	4.	a	<u>                  </u>	in
<u>      </u>	5.	cyto	<u>                  </u>	proto
<u>      </u>	6.	ology	<u>                  </u>	ics
<u>      </u>	7.	bio	<u>                  </u>	most
<u>      </u>	8.	micro	<u>                  </u>	macro
<u>      </u>	9.	genesis	<u>                  </u>	vitro
<u>      </u>	10.	in	<u>                  </u>	ex
<u>      </u>	11.	super	<u>                  </u>	sub
<u>      </u>	12.	physio	<u>                  </u>	psycho

7. Ask students to refer to a glossary or dictionary in order to confirm a meaning suggested by the use of context clues or structure clues. Used on one or two words at a time, the dictionary becomes less scary and more attractive as a tool for scientific reading.

8. Provide for frequent reinforcement and extension of word meanings by utilizing any common type of test lesson or study exercise, e.g. matching, crossword, completion, analogy or grouping. The following are examples of crossword and grouping exercises for vocabulary extension.

### WORD PUZZLE FOR BIOCHEMISTRY:

Directions: To solve the following puzzle, look at the definitions below. Think of a word which fits a definition and has the same number of letters as the number of spaces provided in the corresponding line. Write the word on the line. Do this for each definition.

1.                    \_\_\_ N \_\_\_
2.                    \_\_\_\_ E
3.                    \_\_ U \_\_\_\_\_
4.                    \_\_\_\_\_ T \_\_\_\_\_
5.                    R \_\_\_\_\_
6.                    \_\_ A \_\_\_
7.                    \_\_ L \_\_\_\_\_
8.                    \_\_\_ I \_\_\_
9.                    \_\_\_\_\_ Z \_\_\_\_\_
10.                    \_\_\_\_ A \_\_\_\_\_
11.                    \_\_\_\_ T \_\_\_\_\_
12.                    \_\_ I \_\_\_\_\_
13.                    \_\_\_\_\_ O \_\_\_\_\_
14.                    \_\_\_\_\_ N \_\_\_\_\_

*Definitions:*

1. Chemical bond – electrons transferred between atoms
2. Contains a hydroxide ( $\text{OH}^-$ ) group
3. Contributes to atomic weight, no charge
4. Orbit around atom's nucleus
5. When two or more molecules go together chemically it is called a(n)
6. Formed by neutralization, pH of 7
7. Smallest particle of a substance that retains its properties
8. Have a pH range of 1 – 6
9. Acid and base – salt and water
10. Bond involving shared electrons
11. Determines the atomic number of an atom
12. Atomic \_\_\_\_\_, sum of protons and neutrons in a nucleus
13. Two or more elements bound together in a definite proportion
14. The number of electrons an atom is willing to share, give or accept is called \_\_\_\_\_ number

**VOCABULARY REINFORCEMENT FOR MODERN BIOLOGY:**

Directions: There are five words in each section below. You are to circle two words (in each section) which have something in common with each other, so that when you have done so, the remaining three also have something in common. Notice that there may be

more than one pair of words which you may select to satisfy the requirements. The first one is done for you.

epinephrine

thyroxine

Addison's disease

hyperthyroidism

simple goiter

hormone

endocrine gland

insulin

epinephrine

gonadotropic

acromegaly

somatotropic

giant

midget

pituitary

thymus

pineal body

estrogen

progesterone

puberty

Addison's disease

islets of Langerhans

adrenal

cortin

hypoglycemia

parathyroids

estrogen

ovaries

pituitary

progesterone

cretinism

pancreas

testes

diabetes mellitus

myxedema

testosterone

testes

pituitary

oxytocin

vasopressin

diabetes insipidus

thyroid

hypothyroidism

ACTH

parathormone

anterior lobe

posterior lobe

pituitary

somatotropic hormone

oxytocin

9. Some teachers have found the structured overview useful in identifying their own instructional objectives and in providing their students with an understanding of conceptual relationships that exist among the key terms of science. The following examples include steps necessary for constructing and using a structured overview, sample structured overviews and one teacher's introductory remarks.

*Steps in Constructing and Using Structured Overviews:*

Analyze the vocabulary of the learning task and list all words that you feel are representative of the major concepts that you want the students to understand.

Arrange the list of words until you have a diagram which shows the interrelationships among the concepts particular to the learning task.

Add to the diagram vocabulary concepts, general and/or specific, which you believe are already understood by the students in order to depict relationships between the learning task and the discipline as a whole.

Immediately prior to initiation of the learning task, display the diagram to the students

and explain briefly why you arranged the words as you did. Encourage them to supply as much information as possible.

During the course of the learning task, relate the new information to the structured overview as it seems appropriate. (Or provide the students with key terms printed on 3" x 5" cards and have them arrange the terms in some reasonable fashion.)

### SAMPLE STRUCTURED OVERVIEW FOR THE CHEMISTRY OF LIFE:

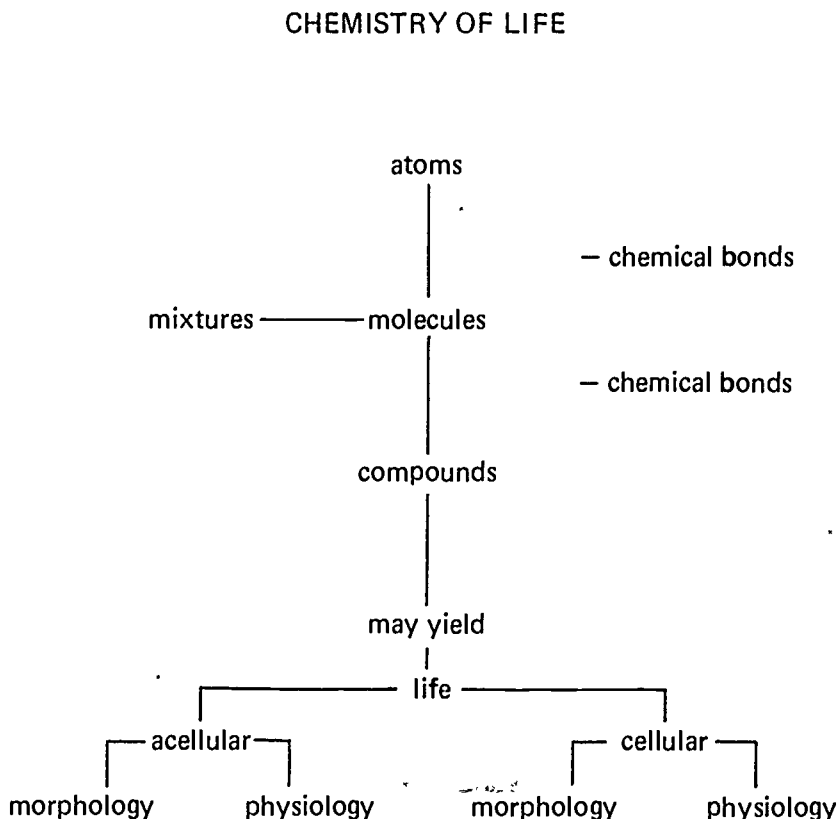

### SAMPLE INTRODUCTORY REMARKS TO STRUCTURED OVERVIEWS:

“This coming unit on biochemistry is a particularly difficult one in that there is a great deal of information covered. I’ll be using diagrams similar to this one to help you see which ideas are most important and how these ideas fit together. Don’t feel that you must memorize these diagrams. Rather, try to relate new and more specific information from large group lectures, and from labs, to the diagrams.”

“This unit of study, as you can see, deals with the chemistry of life. What can you tell

from this diagram? (Elicit student contributions throughout.) Notice first of all that atoms comprise molecules, and molecules make up compounds. Both of these marriages are made possible because of what we call chemical bonds. Molecules which are joined without chemical bonds are called what? Right, mixtures. We will see that in the chemistry of life mixtures are important, but compounds are critical, since they may yield forms of life known as acellular or cellular, etc.”

### SAMPLE STRUCTURED OVERVIEWS

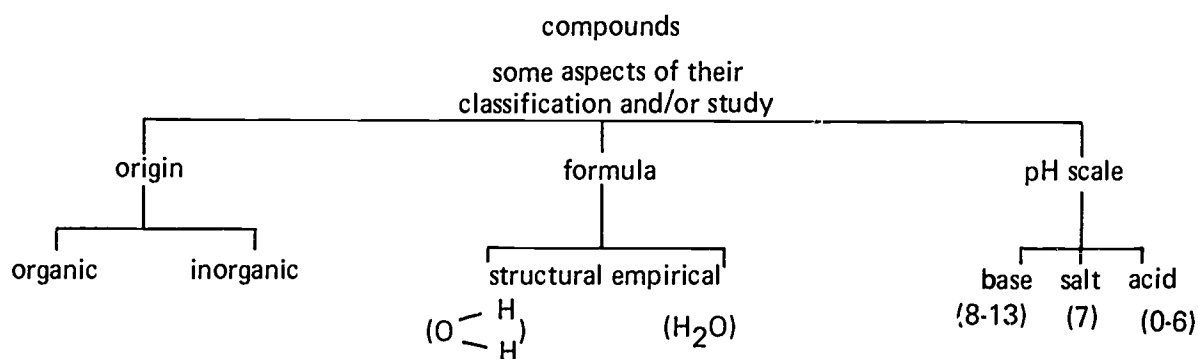
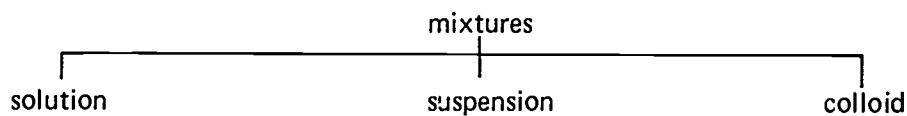
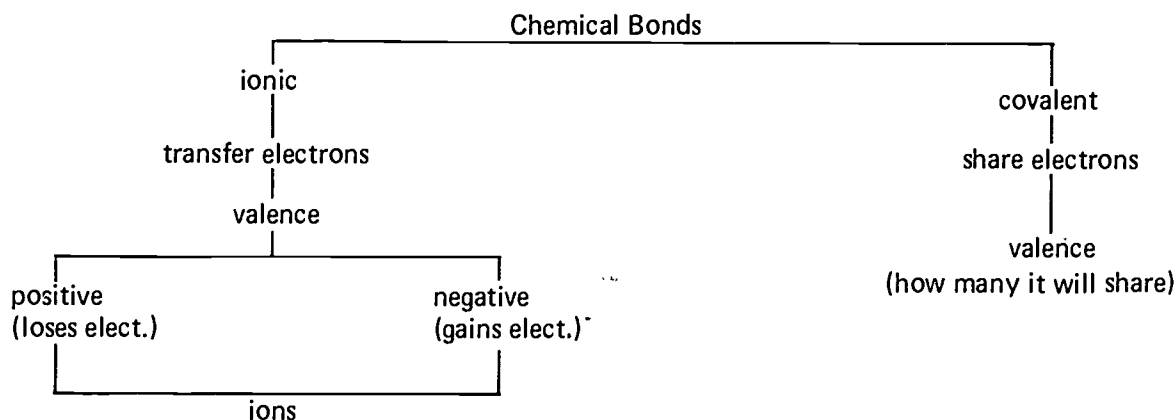
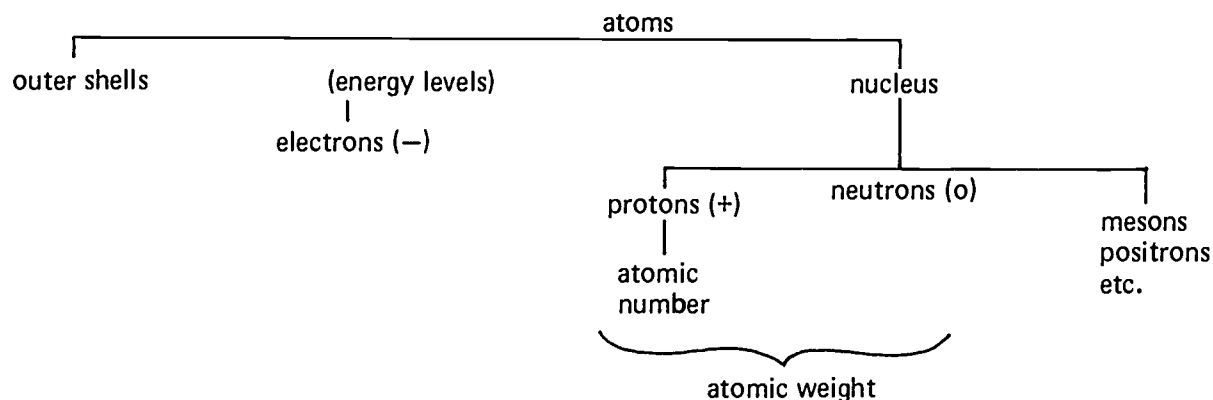



# 19 Comprehension of Science Materials

A. **FOLLOWING DIRECTIONS.** If your goal is to help students *follow directions* accurately, you may wish to:

1. Emphasize the sequential nature of directions with particular attention to the meaning of signal words such as:

first	at last	at that time	already
second	then	subsequently	next
third	now	until	after
last	immediately	while	during
soon	ago	meanwhile	in the meantime
			afterwards

Encourage students to justify (or question) the necessity for rigid adherence to sequence.

2. Suggest to students that they first read an entire set of directions quickly in order to gain an idea of the purpose of the experiment as well as the method. This is followed by a second careful reading coupled with the actual execution of the directions.

3. An effective approach to the reading of directions can be formulated by the science faculty, perhaps in cooperation with a reading specialist. Guidelines which have proven useful to secondary students in performing laboratory experiments have been developed by E.L. Thomas and H.A. Robinson, *Improving Reading in Every Class* (Boston, Mass.: Allyn and Bacon, 1972).

B. **USING GRAPHIC AIDS.** If your goal is to help students use graphic aids such as maps, charts, graphs and pictures, you may wish to:

1. Make it an ironclad rule to focus the students' attention on any visual aids included in a reading assignment. Your discussion should include the purpose for the aid, the meaning(s) of the scale, key or caption, and the relationship of the visual aid to the textual material.

2. Give practical illustrations of visual aids, such as cartoons, graphs, designs, charts and models.

3. Include the preparation of simple visual aids as part of your required science assignments or as one of several options for students. For example, students could be required (or permitted) to make scale drawings of plants or animals as part of their assignments.

4. Be alert for all kinds of meaningful visual aids in mass media. Clippings from newspapers and magazines can be displayed on bulletin boards or other exhibits on current topics of interest in science.

C. **APPREHENDING LITERALLY STATED MAIN POINTS.** If your goal is to help students apprehend literally stated main points expressed by the author, you may wish to:

1. Make it an ironclad rule never to assign required reading without supplying a purpose for your students or helping them to formulate their own purposes for reading.

2. More often than not, require your students to prove that they have satisfied their purpose by reading aloud portions from the text material.

3. While your students are reading silently, walk among them and quietly ask them what their purpose is for reading. If a given student has no purpose, don't let him continue with the assignment until you have reminded him or helped him formulate one.

4. Help students formulate purpose questions using boldface headings found throughout many textbook chapters.

5. Individualize reading assignments by providing more specific purposes for some students, more guidance within each question for other students and locational aids for still other students. For example, the following five questions ask essentially the same thing, each in a different manner. They seem to reveal the teacher's sensitivity to individual differences in successful literal comprehension.

(1) According to the author, what are the major factors that give insects an advantage over many other animals?

(2) Directions: Check the one idea below that seems to best summarize this article. Discuss your answer with members of your group.

- Insects are the most remarkable animals on the earth.
- Insects have six major advantages.
- Insects can nourish themselves on practically anything.
- Insects can always find food because they can fly.
- Insects have been successful because they have six major advantages.

(3) Complete the following statements and discuss your answers with members of your group.

The \_\_\_\_\_ of the insects as a group is due to their having at least \_\_\_\_\_ advantages.

The most outstanding advantage that sets insects apart from all other living things except birds and bats is \_\_\_\_\_.

If conditions become \_\_\_\_\_ at one place, insects find another.

The insect wears its \_\_\_\_\_ on the outside of its body.

The small \_\_\_\_\_ of insects is of great advantage in survival.

Most insects receive survival benefits from the life pattern known as complete \_\_\_\_\_.

Winged adult insects are able to delay \_\_\_\_\_ of eggs.

- (4) Directions: Write the name of the advantage that is described below. The descriptions are listed in Column A. Place your answers in Column B. Discuss your answers.

COLUMN A	COLUMN B
1. This advantage has allowed insects to look widely for food and make good their escape from enemies.	
2. This advantage allows the immature insect to exploit one food supply while the adult insect nourishes itself on something different.	
3. This advantage allows the insect to wait until the proper food plants and living conditions have been found.	
4. This advantage is a remarkable protective armor.	
5. This advantage allows the insect to occupy tiny places in the environment where they can find both food and protection from enemies.	
6. This advantage allows the insect to live in extreme living conditions.	
External skeleton	Complete metamorphosis
Ability to adapt	Delay in fertilization of eggs
Flight	Food supply
Mouth parts	Small size

- (5) Check each word below that indicates an advantage of insects. Discuss your answers with members of your group.

- |                                  |   |
|----------------------------------|---|
| <input type="checkbox"/> flight  | <input type="checkbox"/> complete metamorphosis |
| <input type="checkbox"/> mummies | <input type="checkbox"/> landbound              |

- |  |  |
|--|--|
| <input type="checkbox"/> small size        | <input type="checkbox"/> delayed fertilization |
| <input type="checkbox"/> cocoon            | <input type="checkbox"/> waxes                 |
| <input type="checkbox"/> external skeleton | <input type="checkbox"/> adapt                 |

D. **EVALUATING CRITICALLY.** If your goal is to help your students *evaluate critically*, you may wish to:

1. Make it an ironclad rule to never ignore an additional source on a given topic, print or nonprint, when you become aware of it. Take class time to examine each presentation, compare them, contrast them and elicit from students a value judgment as to which is better and, always, why. Students should be congratulated for simply pointing out different sources and never penalized, e.g., required to write a report on their newly found source.
2. Extend your vocabulary study and reinforcement from word meanings and definitions to a critical examination of concept relationships. Some examples that have been used successfully in classrooms are the following.

**TWO EXAMPLES OF VOCABULARY STUDY:**

Directions: In your study of science it is important to be able to classify ideas. Since ideas are represented by words, this exercise is designed to help you put the words that belong together in the same group. As you read this section in your textbook, take each word that is listed below and classify it under one (or more) of the three headings. The first one is done for you.

matter  
spreads evenly  
weight  
Coca-Cola

definite size  
"burp"  
atoms  
vacuum

changes shape  
properties  
Coca-Cola bottle  
definite shape

Solid

Liquid

Gas

---

---

---

---

---

---

---

---

---

---



---

---

---

---

---

---

---

---

---

---



---

---

---

---

---

---

---

---

---

---

When you are finished, get together with two or three of your classmates and get an agreement on all your answers.

Directions: Each set of words below begin with two words that have a definite relationship, like *editor / newspaper*. Following these words is a single word, like *producer*, then four more words on the next line. You are to pick the word that completes the relationship of the two pairs of words. Underline the correct word.

Example: editor/newspaper : producer/ \_\_\_\_\_  
program, play, building, group

1. water/dehydration : vitamins/ \_\_\_\_\_  
mumps, deficiency, diseases, jaundice, appendicitis
2. protein/organic nutrients : magnesium/ \_\_\_\_\_  
peptides, feces, vitamins, mineral salts
3. pancreas/pancreatic fluid: stomach/ \_\_\_\_\_  
water, saliva, gastric juices, intestinal fluid
4. taste buds/tongue : villi/ \_\_\_\_\_  
mouth, stomach, small intestine, colon
5. pepsin/protein : ptyalin/ \_\_\_\_\_  
oils, fats, starch, sucrose
6. liver/small intestine : salivary glands/ \_\_\_\_\_  
mouth, stomach, small intestine, colon
7. mouth/large intestine : duodenum: \_\_\_\_\_  
esophagus, jejunum, ileum, caecum
8. pancreas/trypsin : intestinal glands/ \_\_\_\_\_  
erepsin, maltase, lactase, sucrase
9. stomach/bulk : pyloric valve/ \_\_\_\_\_  
protein, hydrochloric acid, bile, intestinal juices
10. worn-out hemoglobin/bile : pepsin/ \_\_\_\_\_  
saliva, gastric fluid, intestinal fluid, protein
11. saliva/ptyalin : pancreatic fluid/ \_\_\_\_\_  
trypsin, amylase, lipase, peptones
12. ptyalin/amylase : bile/ \_\_\_\_\_  
peptones, sucrase, maltase, lipase

3. Develop a list of "authorities" in various scientific areas. Then collect data concerning their relative training, experience, present position and other criteria for competence. Collect examples of authoritative judgment, both competent and otherwise, for class discussion.

4. Contrast actual specimens with pictures, diagrams or verbal descriptions. Note the increasing loss of accuracy.
  5. Include guidance in critical evaluation as part of required reading assignments. This can and should be done with even the less able students and at all grade levels.
- E. **APPLICATION OF LEARNING.** If your goal is to help students *apply products of reading* to practical situations and problems, you may wish to:
1. Make it an ironclad rule to precede and/or follow up required reading with experiments and problems which demonstrate the principles under study. Show students that you place a high value on their attempts to contribute and discuss such examples. Encourage special projects, supplementary reading and exploration, exhibits, bulletin board displays and other efforts.
  2. Always point out the relationship of reading assignments, laboratory experiments and real life applications of the principles under study.
  3. Devise or locate projects which require the students to use principles under study in order to care for animals, predict the weather, investigate compliance with pollution standards, etc.
  4. Include simulated applications as part of required reading wherever possible.

F. **RESOURCE LIST FOR POOR READERS IN SCIENCE**

1. **Textbooks**

*Ideas and Investigations in Science: Biology.* Harry Wong and Malvin Dolmatz. Englewood Cliffs, N.J.: Prentice-Hall, 1971.

*Ideas and Investigations in Science: Physical Science.* Harry Wong and Malvin Dolmatz. Englewood Cliffs, N.J.: Prentice-Hall, 1971.

*Pathways in Science: Biology.* Joseph Oxenhorn and Michael Idelson. New York: Globe, 1968.

*Pathways in Science: Chemistry.* Joseph Oxenhorn and Michael Idelson. New York: Globe, 1968.

*Pathways in Science: Earth Science.* Joseph Oxenhorn and Michael Idelson. New York: Globe, 1968.

*Pathways in Science: Physics.* Joseph Oxenhorn and Michael Idelson. New York: Globe, 1968.

*Patterns and Processes.* Biological Sciences Curriculum Study. Holt, Rinehart and Winston, 1968.

*Web of Life: Ecology.* George McCue. Beverly Hills, Calif.: Benziger, Inc., 1971.

## 2. Booklists

*The AAAS Science Book List.* H. J. Deason. 3rd Ed. 1515 Massachusetts Av., NW, Washington, D.C. 20005: American Association for the Advancement of Science, 1970.

*A Place to Start.* Robert Leibert. 52nd and Holmes, Kansas City, Missouri 64110: Reading Center, University of Missouri.

*Culturally Disadvantaged.* R. E. Booth, T. Manheim, D. A. Satterthwaite and G. L. Dardarian. Detroit: Wayne State University Press, 1967.

*Good Reading for Poor Readers.* G. S. Spache. Champaign, Ill.: Garrard Publishing Co., 1974.

*High Interest/Easy Reading for Junior and Senior High School Students,* Marian White. National Council of Teachers of English, 1972.

*High Interest - Low Vocabulary Science Books.* M. E. Gott and J. R. Wiles. Boulder, Colorado: Bureau of Educational Research, School of Education, University of Colorado.

*Large Type Books in Print.* R. A. Laudau and J. S. Nyren. New York: R. R. Bowker Publishing Co., 1970.

*Scholastic Book Services Catalogue.* Science Collection (29 books) Science and Fiction (13 books). New York: R. R. Bowker Publishing Co., 1970.

*Science Books: A Quarterly Review.* Detailed reviews of science books for use with elementary, secondary and junior college students. 1515 Massachusetts Av., NW, Washington, D.C. 20005: American Association for the Advancement of Science.

*Science for Youth, An Annotated Bibliography for Children and Young Adults,* H. Logasa and N. J. Brooklawn. Ocean City, N.J.: McKinley Publishing Co., 1963.

## 3. Book Clubs

Falcon Book Club. 1 W. 39th St., New York, N.Y. 10018: Young Reader's Press.

Popular Science Book Club. 44 Hillside Av. Manhasset, N.Y. 11030.

## 4. Magazines

*American Forests.* 919 17th St. NW, Washington, D.C. 20016: American Forestry Association.

*Animal Kingdom.* 185th St. and Southern Blvd., New York, N.Y. 10033: New York Zoological Society.

*Audubon Magazine.* 1130 Fifth Av., New York, N.Y. 10028: National Audubon Society.

*Chemistry.* 1155 16th St. NW, Washington, D.C. 20036: American Chemical Society.

*Current Science and Aviation.* 1250 Fairwood Av., Columbus, Ohio 43216: American Education Publications, Education Center.

*Junior Natural History.* Central Park West at 79th St., New York, N.Y. 10024: American Museum of Natural History.

*Mechanix Illustrated.* 67 W. 44th St., New York, N.Y. 10036: Fawcett Publications, Inc.

*Natural History.* Central Park West at 79th St., New York, N.Y. 10024: American Museum of Natural History.

*Nature and Science.* Garden City, N.Y.: Natural History Press.

*Organic Gardening and Farming.* 33 E. Minor St., Emmaus, Penn. 18049: Rodak Press.

*Popular Mechanics.* 575 Lexington Av., New York, N.Y. 10022: Popular Mechanics Co.

*Popular Science Monthly.* 355 Lexington Av., New York, N.Y. 10017: Popular Science Publishing Co.

*Reader's Digest.* Pleasantville, N.Y. 10570: Reader's Digest Services. (Fine series including, "I Am Joe's Eye," "I am Jane's Breast," etc., a personalized description of the structure and function of human organs and systems.)

*Science Digest.* 959 Eighth Av., New York, N.Y.: The Hearst Corp.

*Science Reading Adventures.* Columbus, Ohio 43216: American Education Publications, Education Center.

*Science World.* 50 W. 44th St., New York, N.Y. 10036: Scholastic Magazines, Inc.

*Sea Frontiers.* 10 Rikenbacker Causeway, Virginia Key, Miami, Fla. 33149: International Oceanographic Foundation.

*Today's Health.* 535 N. Dearborn St., Chicago, Ill. 60610: American Medical Association.

*Young Americans.* 431 E. 47th St., New York, N.Y. 10022: Strong Publications, Inc.

##### 5. Free Materials

Abbott Laboratories, Vitamin Characters.

American Medical Association, 535 N. Dearborn St., Chicago, Ill. 60610. "The Miracle of Life" (1966) 40 cents, 8½ x 11" 24 pages, illustrated.

LaMotte Chemical Products Co., Chestertown, Md. 21620. Soil and Water Booklets, "A Study of Soil Science" and "A Study of Water Quality."

Eli Lilly Co., Public Relations Division, P. O. Box 618, Indianapolis 46206. Wall Charts "Combat with a Traitor," "The Synthesis of Protein" and "The Fact of Life."

Wards Natural Science Establishment, P. O. Box 1712, Rochester, N.Y. 14603.



The science teacher is advised to approach these recommendations with caution. Not all reading experts (or science specialists) will agree on the minimum skills or competencies. If, for example, you have a pet reading or thinking skill that you have emphasized in your science classes, continue to do so by all means. The list included here may simply alert you to additional areas of concern for you and your students. Similarly, this section contains only a small sample of teaching ideas designed to help students increase their facility with each skill mentioned. No single idea can solve the continuing problem of reading in the science areas; therefore none of these ideas is offered as a panacea. After reflecting on the examples shown and illustrated, most teachers will be able to generate a number of additional activities for increasing students' competence in a given skill area. Finally, the materials listed as resources for the poor reader in science have been included because of their relevance to scientific concerns, their relatively high interest and their ease and appeal for reading. Closer examination, however, may reveal them to be inappropriate for your particular curriculum or grade level. In addition, they may prove to be unappealing or even too difficult for your students to read.

# 20 Reading Development in Mathematics

Reading mathematics is a more complicated process than reading prose material is. There is little of the stereotypic reading teacher in the modern mathematician-educator. Teaching reading skills is not the purpose of emphasizing reading in the mathematics classroom; rather, teaching functional reading — reading to learn — is the objective. Students are expected to compute, reason and be able to do mathematical assignments. The idea of reading mathematics must involve both the discipline-content of mathematics and the learning process by which the content is learned.

The intent of this discussion is not to make the mathematics teacher a teacher of reading, but to suggest ways in which emphasizing particular techniques can aid reading and, thus, aid the learning of mathematics.

Topics which will be dealt with include (1) general concerns of mathematical reading, (2) coming to terms or knowing the language and vocabulary of mathematics, (3) comprehension skills and (4) unit plans.

## A. GENERAL CONCERNS IN READING MATHEMATICS

1. **Recognition.** In reading it is sometimes enough to be able to “sound out” a word through the letter-sound correspondence of our language. In mathematics it is not enough; most words and mathematics symbols, while having sounds attached to them, represent abstractions and are apparently meaningless until a relationship of ideas is established. In order for students with particular difficulties to learn to pronounce and recognize special math-words or math-symbols, a teacher might construct an instant recognition exercise similar to the model in the science section of the guide. Such an exercise might appear to be a simple matching exercise of words in isolation. The purpose is to have the child recognize the word and hear the word twice as it is pronounced initially either by the teacher or another student who has mastered the word.

### SAMPLE MODEL: MATH-WORD RECOGNITION EXERCISE

Directions: Underline the word in the right four columns which is the same as the word in the far left column.

add	addition	add	angle	area
addition	addition	arithmetic	average	area
area	add	angle	area	base
base-ten	add	angle	average	base-ten
chart	check	closed	chart	count

Find the sentence in which the word appears in your text material. What do you think the word means in that sentence? Write your hypothesis (guess) on the lines following the word.

Add \_\_\_\_\_

Addition \_\_\_\_\_

Area \_\_\_\_\_

Base-ten \_\_\_\_\_

Chart \_\_\_\_\_

In this exercise not only does the student need to recognize the word in isolation, but the additional portion of the exercise requires the student to locate the content of the word within the passage which must be read. The student then uses the best intuition in order to arrive at a reasonable meaning for that word or phrase using all the available evidence of word attack or contextual clues. (See the English section for a more complete idea of contextual clues; see the section on cloze procedures as well.) The same kind of exercise can be used to reinforce the conceptualization of a math-symbol.

#### SAMPLE MODEL: MATH-SYMBOL RECOGNITION EXERCISE

Circle the symbol which is the same as that found in the left column.

$>$	$<$	$=$	$\div$	$\dot{>}$
$=$	$-$	$+$	$<$	$\div$
$\phi$	$\phi$	$\eta$	$\varepsilon$	$\leq$

Circle the symbol which represents the word phrase in the left column.

Add	$=$	$+$	$\div$	$\times$
Divide	$+$	$\div$	$\times$	$\varepsilon$
Empty set	$=$	$\neq$	$\phi$	$+$

No matter the purpose in mathematics, the student is reinforcing recognition patterns and, depending on the sophistication of the exercise, is developing *rapid* recognition and comprehension of the meanings of the term *symbol*.

2. **Study Skills.** In several other sections of the guide, study habits are described in some detail. Good habits on the part of young math readers aid the rapidity of acquiring independence in learning. Learning the discipline of mathematics is rigorous enough when independence is mastered, but in order to master mathematics, the skill of studying needs to be developed. SQ3R and skimming are two key techniques because they enable the student to preview the problem for possible solutions.

3. **Readability.** Another general concern is the problem of readability. In a new book by Robert Kane, Mary Ann Byrne and Mary Ann Hater entitled *Helping Children Read Mathematics* (New York: American Book Co., 1974), two formulas for assessing mathematical language in text materials are suggested. Although somewhat cumbersome, the process is noteworthy in its undertaking. Otherwise an experienced teacher can estimate the approximate level based on experience.

B. **DEVELOPING VOCABULARY IN READING MATHEMATICS.** The difficulties with terms may be attributed to four main areas: (1) an operation may have several names, e.g., minus, take away and subtract, (2) meanings of technical mathematics terms may differ from common use, e.g., set, chart and double (3) terms may be highly abstract or unfamiliar and (4) there is a symbolic "language of mathematics" to be learned, e.g.,

$$\varepsilon \quad \mu = \emptyset \quad \div \quad \therefore \quad .$$

To aid students in dealing with vocabulary difficulties, the teacher can present terms in a structured overview similar to those suggested in the English section of this curriculum guide. The students can also be given periodic pretests of vocabulary in addition to vocabulary games and exercises.

**SAMPLE MODEL: CHARTING PRETEST FINDINGS**

Names	<i>Items on Test Missed</i>				
	1	2	3	4	5
John	✓	X	✓	X	✓
Sue	✓	✓	✓	X	✓
Betty	✓	X	X	X	✓
Joe	✓	X	X	X	X

By noting the items missed by each student, the instructor can determine which items need emphasis in whole class teaching. He can further structure small groups according to student needs based on the items missed on the pretest.

Important vocabulary and technical terms should be included in the pretest. The instructor should aid students in noting relationships within formulas and in understanding technical synonyms such as "times" "multiplied by" and "find the product."

To develop proficiency of understanding mathematics, students need many opportunities to hear, see and use mathematical terms.

**C. DIFFICULTIES WITH COMPREHENSION AND SPEED**

**1. How to Develop Comprehension**

- (1) Have students analyze the problem by noting the items given, the conditions and the solution requested.
- (2) A diagram of the problem will often be of help.
- (3) Determine what computations are needed to solve the problem.
- (4) Determine what information not provided within the problem is needed to arrive at a solution.
- (5) Estimate the answer.

- (6) Compute the answer.
- (7) Check the answer.
- (8) Through the construction and use of models, tables, graphs and charts, students can gain new and increased understandings of concepts.

2. **Aids in Reading Difficult Texts**

- (1) Use multiple texts with varying levels of difficulty.
- (2) Rewrite materials using less complex wording.
- (3) Help students develop the habit of previewing materials to gain an overall understanding of a unit.
- (4) Provide many opportunities for students to develop and strengthen their mathematical vocabulary.
- (5) A class discussion of difficult problems will be helpful.

D. **UNITS OF INSTRUCTION.** When teachers plan units in mathematics topics, frequently the only consideration is for the mathematics involved and the problem to be solved. In the following units of instruction, the teachers developing the unit used many reading-learning skill techniques which are somewhat more adequately described in the English section of this guide. A brief annotation of the technique is provided here using the divided page technique.

These units were constructed by teachers under the direction of Dr. Joseph L. Vaughan, University of Arizona, and are intended for use in the classroom. They are used with Dr. Vaughan's permission.

**SAMPLE MODEL: UNIT OF INSTRUCTION**

A suggested unit of instruction includes a structured overview, a list of concepts for inspection, a books and materials listing and several suggested activities.

*Structured Overview: Prove It!*

Developed by Danny Harris, mathematics teacher at Thorper Junior High School, Hampton, Virginia.

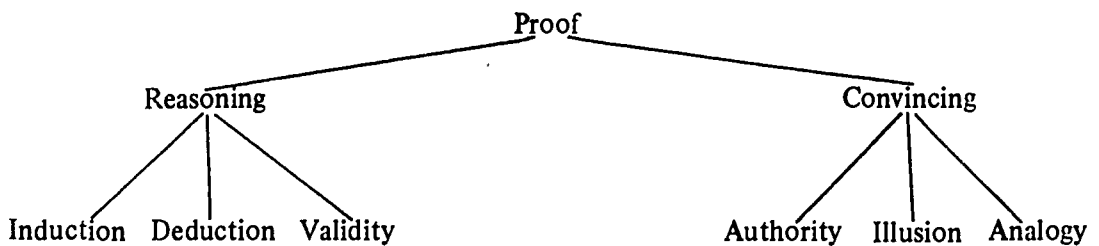

The structured overview is an attempt to introduce vocabulary in a systematic manner to indicate relationships which are important in developing an idea of what topics or new words will have to become familiar or known. It should also be based on vocabulary (or topics) of which the student has some knowledge already.

*Concepts for Inspection:*

These are the concepts which the teacher extracts for the basis of instruction. The activities should reinforce (teach) the concepts.

1. Is there anything common to proving and convincing? Yes, agreement.
2. Consulting authorities may be convincing, but not all authorities agree.
3. Seeing is not always believing.
4. Analogy can help discover patterns, but does not prove things true.
5. How to determine valid conclusions.
6. Inductive reasoning reaches a general conclusion from a specific case.
7. Deductive reasoning reaches a conclusion from a general statement.
8. Deduction may be valid, but not true.

*Books and Materials:*

This chart indicates how various materials or teaching techniques will aid learning during the course of the unit. The numbers of concepts refer to the numbered concepts listed previously.

<i>Books and Materials</i>	<i>Concepts</i>							
	<i>1</i>	<i>2</i>	<i>3</i>	<i>4</i>	<i>5</i>	<i>6</i>	<i>7</i>	<i>8</i>
<i>Mathematics: A Modern Approach</i> Second Course Wilcox, 1966	X	X	X	X	X	X	X	X
Illusion Worksheets			X					
Pencils, Glass and Water			X					
Can, Ruler and Paper				X		X		
Coins (pennies – 6)				X		X		
<i>Practice for Modern Mathematics</i> Vest, 1971			X					
Dictionary	X	X	X	X	X	X	X	
<i>Sport Magazine</i> , Feb., 1974			X					

*Books and Materials*

*National Geographic*, Sept., 1973

Overhead Projector

*Enquirer*, Feb. 10, 1974

Outline of Structured Overview –  
not filled in

*Mathematics: A Human Endeavor*  
Jacobs, 1970

*Concepts*

	1	2	3	4	5	6	7	8
<i>National Geographic</i> , Sept., 1973		X						
Overhead Projector	X	X	X	X	X	X	X	
<i>Enquirer</i> , Feb. 10, 1974		X						
Outline of Structured Overview – not filled in	X	X	X	X	X	X	X	
<i>Mathematics: A Human Endeavor</i> Jacobs, 1970			X			X	X	X

The activities are selected to provide for learning in each concept area as specified in this activities chart.

*Activities*

*Concepts*

1 2 3 4 5 6 7 8

1. Look up “prove” and “convince” in the dictionary. Write their definitions. Write one sentence using each word. Explain how you think proving and convincing are different. Explain how you feel they are alike.

X X

2. Small group (in pairs). Pick a statement from the can. Prove or convince your partner that it is true. Reverse role. Note: Use statements in selection.

a. A \$50 coat is an expensive coat.

X X X X X

b. 60 is a high score on a test.

c. Tall girls are good dancers.

d.  $\frac{3}{4}$  and  $\frac{6}{8}$  are names for the same number.

e. Good athletes are short boys.

f. Students with red hair are the brightest.

3. Teacher directed activity.  
Overhead – introduction to unit using structured overview. Fill in.

X X

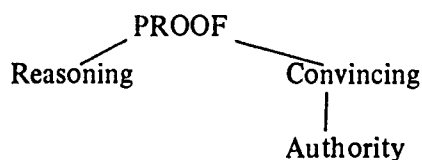

“To prove or convince means to agree on some definition or method.”

Activities

Concepts

1 2 3 4 5 6 7 8

- |   |   |   |   |  |  |  |  |  |
|---|---|---|---|--|--|--|--|--|
| 4. We often “prove” to another person that something is correct by using the method of consulting an authority. Consult an authority to “prove” or “disprove” the following statements. A reference study-skills worksheet will aid vocabulary development and locational skills. | X |   |   |  |  |  |  |  |
| 5. Make up 10 statements which a person would have to consult an authority to “prove.”  | X |   |   |  |  |  |  |  |
| 6. <i>Mathematics: A Modern Approach</i> , p. 315 (1-5), p. 316 (14-24)   | X |   |   |  |  |  |  |  |
| 7. Authorities disagree. Therefore, an authority really “proves” nothing. For example, look through <i>National Enquirer</i> and find all the different “diets” which some authority claims is best.  | X |   |   |  |  |  |  |  |
| 8. Authorities are not always right. Write a sentence or two about a case that you have seen or know about — where a doctor makes the wrong diagnosis of a sick person. Do you know of any other examples where an authority does not really prove or agree?                      | X |   |   |  |  |  |  |  |
| 9. “Frank weighs more than Henry,” said Steve. “I don’t believe it!” responded John. “Anyone can tell by looking.” Can you really tell by looking? Consider the figures on p. 20, <i>Mathematics: A Human Endeavor</i> .  | X |   |   |  |  |  |  |  |
| 10. Look “illusion” up in the dictionary. Write a definition for this word and then write three sentences using the word “illusion,” expressing the idea “seeing is not really believing.”  | X |   |   |  |  |  |  |  |
| 11. Measure the length of this line segment AB.<br>A _____ B  | X | X | X |  |  |  |  |  |



Activities

Concepts

1 2 3 4 5 6 7 8

Is your measure the same as that obtained by other members of your class?

12. Insert part of a pencil in a glass of water. Observe length of pencil from the side of the glass. Does it appear to be in one straight piece?

X X

13. Teacher directed discussion, *Mathematics: A Human Endeavor*, p. 17. Study cartoon, then read first paragraph, p. 17. Discussion of illusion.

X X

14. *Mathematics: A Human Endeavor*, p. 19. Study picture and find the illusion. Write a couple of sentences describing the illusion.

X

15. Small group, teacher-directed exercise. Examples of reasoning by analogy.

$$5 + 6 = 11 \quad 11 > 5 \text{ and } 11 > 6$$

$$-5 + -6 = -11 \text{ but } -11 > 5$$

$$-11 > 6 \text{ is not true.}$$

X

Jim is 6' 4" and is a good basketball player. Bill is also 6'4". Bill concludes that he should be a good basketball player.

Discussion of examples on pp. 318-319, *Math: A Modern Approach*.

16. Look up "analogy" in dictionary. Write out definition and two sentences using the term.

X X

17. Small group activity, p. 319, Exercise (1-1), *Math: A Modern Approach*.

X

18. Teacher directed activity of overhead project - structural overview. Fill in and review: "authority," "illusion," "analogy." Introduction of the two basic methods of reasoning - induction and deduction.

X X X X X X

*Activities*

*Concepts*

1 2 3 4 5 6 7 8

- |   |   |
|---|---|
| <p>19. Induction – introductory example. Virginia visited Hampton for two weeks last summer. Each day she heard it rained at about 4:00 in the afternoon. She concluded that it must rain every afternoon in Hampton. Do you think her conclusion follows from her experience? How could we prove that her conclusion was incorrect?</p> <p>20. Material – 6 coins (pennies) and paper, worksheet on induction – discover patterns (see worksheet).</p> <p>21. Material – can, ruler or straight edge, paper and worksheet on induction (see worksheets). This is a manipulation activity to develop the necessary concept. It also aids following directions.</p> <p>22. Small group, teacher-directed exercise. Discovering patterns, Bode's numbers and the planets, p. 15, <i>Math: A Human Endeavor</i>. This is a form of a three-level study guide. Notice how the teacher asks the child to move from concrete factual evidence to inferring (guessing) what will take place to applying the process in Question No. 5.</p> <p>23. Two million people were vaccinated against smallpox. None of them contracted the disease. It was concluded that if a person is vaccinated against smallpox, he will not contract the disease.</p> <p style="margin-left: 2em;">a. Was the above conclusion found by inductive reasoning?</p> <p style="margin-left: 2em;">b. Is the conclusion reasonable?</p> <p style="margin-left: 2em;">c. Why is the conclusion here more reasonable than the one about Hampton?</p> <p>24. <i>Math: A Modern Approach</i>, pp. 322-323, Exercise 1-11.</p> | <p>X</p> <p></p> <p></p> <p></p> <p>X</p> <p></p> <p></p> <p>X</p> <p></p> <p></p> <p>X</p> |
|---|---|

Activities

Concepts

1 2 3 4 5 6 7 8

- |   |  |
|---|--|
| <p>25. Small group activity. It has been found that the larger the number of cases, the more reasonable the conclusion. Go back to pp. 322-323 (1-11). In which exercises do the conclusions seem most reasonable? Why?</p> <p>26. Teacher-directed activity.</p> <p style="margin-left: 20px;">a. A conclusion may be a true statement, but not a valid conclusion. Example, bottom p. 323, <i>Math: A Modern Approach</i>.</p> <p style="margin-left: 20px;">b. A conclusion may be valid but not true. Example, top of p. 324, <i>Math: A Modern Approach</i>.</p> <p style="margin-left: 20px;">c. A conclusion may be valid and also true. Example, p. 324. Discuss and answer questions.</p> <p>27. Find and write definition for "valid" or "validity." Use valid in four sentences.</p> <p>28. Small group. <i>Mathematics: A Modern Approach</i>, pp. 324-325 (1-4) (6-8) (10-12). Is statement (c) a valid conclusion from (a) and (b)? If the answer is no, tell why.</p> <p>29. Write five exercises like those on pp. 324-325 (<i>Modern Approach</i>) which are valid conclusions from statements (a) and (b).</p> <p>30. Write five exercises like those on pp. 324-325 which are not valid conclusions for statements (a) and (b).</p> <p>31. Large group discussion, deduction. <i>Math: A Modern Approach</i>, p. 326, Exercise No. 1; p. 327, Exercise No. 3. Take notes: definition and structure of deductive reasoning.</p> | <p>—</p> <p>X X X</p> <p>X X</p> <p>X X</p> <p>X</p> <p>X</p> <p>X X X</p> |
|---|--|

Activities	Concepts							
	1	2	3	4	5	6	7	8
32. Small group discussion, p. 327, <i>Math: A Modern Approach</i> (1-6). a. Tell whether conclusions are by deductive reasoning. b. If not, tell why.					X		X	
33. A large group discussion, teacher-directed, in Activity No. 32.	X	X			X		X	X
34. Individual exercise, pp. 328 (1-11) – 329 (14-19), <i>Math: A Modern Approach</i> .							X	
35. Small group: a. Without discussing the answers for Activity No. 34, vote on each question. Keep a record of the results on each problem. By induction, what are the correct answers for activities? b. Discuss or “prove” your answer correct to your small group until everyone agrees.						X		
	X	X			X		X	X
36. Large group: a. Authority, the teacher, will go over answers with all groups. b. Write a statement which explains why those answers are not deductive reasoning.		X			X		X	
37. <i>Math: A Human Endeavor</i> , pp. 36 (1, 2, 3) – 37 (6,7). Check answer with teacher.							X	X
38. Unscramble term of unit (see worksheet). Vocabulary reinforcing activity makes a game (puzzle) with mathematics terms. No one ever said reading mathematics couldn't be fun.	X	X	X	X	X	X	X	X
39. Review of unit: overhead project. Fill in all structured overview, teacher-directed large groups.	X	X	X	X	X	X	X	X
40. Study illusion worksheets. Answer questions on each page.			X					

Activities

41. Extra credit, *Math: A Human Endeavor*, Number Trick — Induction and Deduction, pp. 30-31 — read pp. 32(11)-33(1-5).

Concepts

1	2	3	4	5	6	7	8
					X	X	

SAMPLE WORKSHEETS

Activity No. 4

- The correct spelling is "percent." The correct spelling is "indefinite." *Dictionary*
- One mile equals 5,280 feet. *Practice for Modern Mathematics*, p. 95
- The tallest player in the National Basketball Association history according to official rosters is Kareem-Abdul-Jabbar. *Sports Magazine*, p. 22, p. 102.  
The longest game in major league history was 26 innings.
- The moon has gravity  $\frac{1}{6}$  that of the earth's. *National Geographic* and any science teacher.
- $8 \times 9 = 72$   
Where would you ask? Why?
- The Senate of the U.S. is made up of 110 members.
- The total enrollment of Thorpe is 1,107 students.

Activity No. 21

Take the can and draw around it to make a circle. Mark two points on the circle and connect these points with a straight line.

- Into how many parts has the region inside the circle been divided?

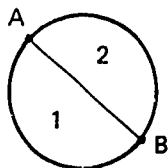

- Draw another circle and place 3 points on it. Connect each point to the others. How many parts are in the circle this time?

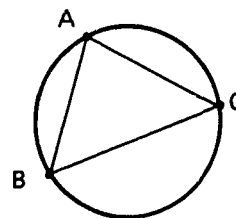

- Do the same for 4 and 5 points, connecting each point at with all others with a straight line.

Example

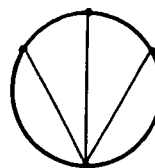

then

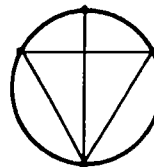

becomes

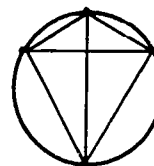

- Inductive reasoning would tell us that 6 points would be how many parts?
  - Draw a circle and place 6 points on it. Connect all lines to all other points, then count.
  - Did you get 32? Does inductive reasoning work in all situations?

<i>Number of points</i>	<i>Number of parts</i>
2	2
3	4
4	8
5	16

Activity No. 22

If you flip one coin, there are two possible outcomes — a *head* and a *tail*.

1. If you flip two coins, there are four outcomes. What are they?
2. When you flip three coins at the same time, there are eight possibilities. (“H” stands for heads, “T” stands for tails)

HHH HHT HTH THH

What are the last four outcomes?

Number of coins	Number of outcomes
1	2
2	4
3	8
4	16

3. Using inductive reasoning, what do you think are the number of outcomes with four coins? See table to check answer.
4. Write down all the possibilities with four coins.
5. How many should there be for five coins? Why? (Explain)

Activity No. 38

ROOFP \_\_\_\_\_  
 TAILDITYV \_\_\_\_\_  
 THOSEITRAUI \_\_\_\_\_  
 MAGALOY \_\_\_\_\_  
 TUCINDION \_\_\_\_\_  
 SEAGOINGNR \_\_\_\_\_  
 VICETEDDU \_\_\_\_\_  
 LIONLIUS \_\_\_\_\_

## SAMPLE UNIT MODEL: RATIONAL NUMBERS

### Anticipated Outcomes:

1. An ability to recognize rational numbers.
2. An understanding of the meaning of rational numbers and rational units.
3. An understanding of how to make a rational number.
4. An understanding of making rationals with a common denominator.
5. An understanding of the effect of changing the denominator or numerator.
6. The ability to change improper rationals to mixed rationals.
7. The ability to reduce rationals to lowest terms.
8. An understanding of and skills in using a common denominator in adding and subtracting.

### *Books and Materials*

Newspaper clippings  
Flannel board and fractional parts  
Graph paper  
Math applicator kit (SRA)  
Math activity worksheet masters  
Fractional wheel  
*Mathematics – Structure and Skills*  
Puzzles (basic math book)  
Compass and ruler  
Math tapes program  
*Teaching Elementary School Math*  
Decimal Equivalent Chart

### *Vocabulary*

Rational number  
Numerator  
Denominator  
Fraction  
Multiplication  
Addition  
Subtraction  
Equivalent  
Division  
Reciprocal  
Cancellation  
Improper fraction  
Proper fraction  
Mixed fraction  
Fractional unit

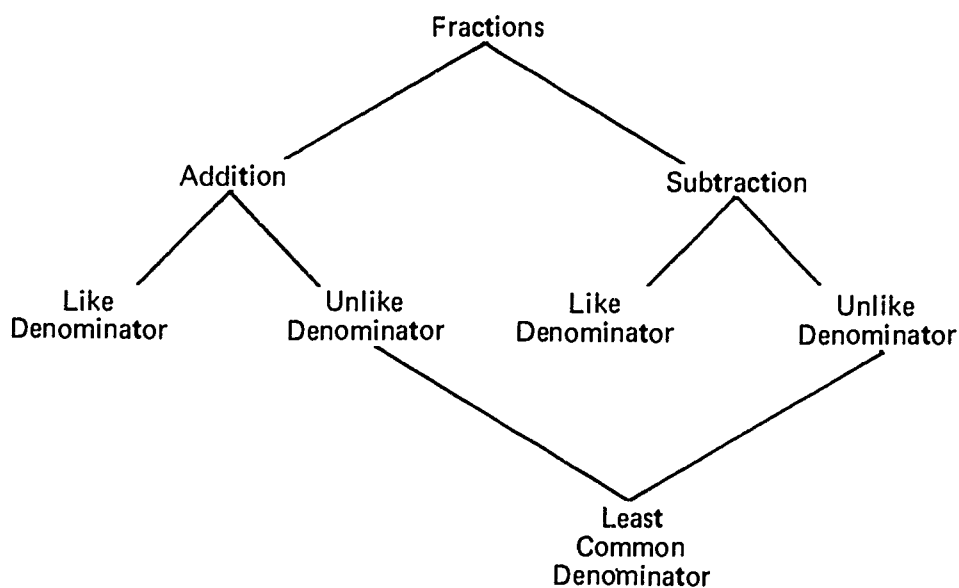

Activities:

All students – Bring in and display pictures and articles that use fractions in an important way.

All students – Speech by a parent or local personality on the importance in everyday life of ability to work with fractions.

Station A – Making Rationals. Choose a newspaper clipping of sports scores. Use the breakdown of scores in the construction of fraction problems.

Station B – Dividing a set of objects to show  $1/6$ ,  $1/8$ ,  $2/3$  and  $3/4$ . Use the flannel board to divide the sets of identical flannel-made objects into 6, 8, 2, 3 and 4 equal groups. Now use this procedure to name one of each part of each group.

Station C – Get a pass, go to the library and do some research on the use of fractions in industry. Make this a written report.

Station D – Get the filmstrip previewer and preview the filmstrip in the station. Try to work the problems at the end.

Station E – Get two sheets of plain paper, a compass and a box of crayons. Draw two circles on both sides of the two sheets of paper. Divide the circles into 2, 3, 4, 5, 6, 7, 8 and 10 sections. Start with the first circle by coloring one section, the next two sections, the next three sections and so on until a section of all the circles has been colored. Now make a list of all the fractions showing what part was shaded in each circle. Make a second list with fractions showing what part of the circle was not colored.

Example:

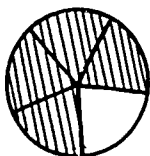

Colored – 4 out of 5, or  $4/5$ .

Not Colored – 1 out of 5, or  $1/5$ .

Station F – Look at the top 20 and let all even numbered records be the denominators and the odd numbered records be the numerator.

Example:

$$\frac{\text{TSOP}}{\text{Payback}} = \frac{1}{2}$$

$$\frac{\text{TSOP}}{\text{Keep It in the Family}} = \frac{1}{4}$$

Make as many different fractions as possible.

SOUL BROTHERS TOP 20

Title, Artist and Label

- |                          |       |                                   |
|--------------------------|-------|-----------------------------------|
| 1. TSOP                  | ..... | MFSB (Philadelphia International) |
| 2. PAYBACK               | ..... | James Brown (Polydor)             |
| 3. LOOKING FOR A LOVE    | ..... | Bobby Womack (United Artists)     |
| 4. KEEP IT IN THE FAMILY | ..... | Leon Haywood (20th Century)       |



5. DANCING MACHINE . . . . . Jackson Five (Motown)
6. BEST THING THAT EVERY HAPPENED TO ME . . . . . Gladys Knight & The Pips (Buddah)
7. OUTSIDE WOMAN . . . . . Bloodstone (London)
8. MIGHTY LOVE . . . . . The Spinners (Atlantic)
9. THANKS FOR SAVING MY LIFE . . . . . Billy Paul (Philadelphia International)
10. IT'S BEEN A LONG TIME . . . . . New Birth (RCA)
11. BOOGIE DOWN . . . . . Eddie Kendricks (Tamla)
12. MY MISTAKE . . . . . Diana Ross and Marvin Gaye (Motown)
13. JUST DON'T WANNA BE LONELY . . . . . Main Ingredient (RCA)
14. I LIKE TO LIVE THE LOVE . . . . . B. B. King (ABC)
15. TRYING TO HOLD ON . . . . . Lamont Dozier (ABC/Dunhill)
16. HEAVENLY . . . . . The Temptations (Gordy)
17. HONEY PLEASE . . . . . Barry White (20th Century)
18. YOU MAKE ME FEEL BRAND NEW . . . . . Stylistics (Avco)
19. I WISH IT WAS ME . . . . . Tyrone Davis (Dakar)
20. SEXY MAMA . . . . . The Moments (Stang)

Station G – The recipe for Strawberry Charlotte makes 10 servings. How much of each ingredient would you need to make only 5 servings? Also, 2 servings?

Example: If it takes 2 cups of cream to make 10 servings, it would take half as much (or 1 cup of cream) to make 5 servings.

Makes 10 servings. Each serving: 296 cal.; 3 gms. P.; 19 gms. F.; 30.7 gms. C. Source of vitamin C.

- 2 envelopes unflavored gelatin
- ½ cup water
- 1 quart firm, ripe strawberries, washed and hulled
- 1 cup sugar
- 2 teaspoons lemon juice
- 1 teaspoon vanilla
- 4 drops red food coloring
- 1 package (3 ounces) ladyfingers
- 2 cups (1 pint) heavy cream

Station H – Card Fun.

Activities: What part of the cards are red? What part of the cards are black? What part of the cards are spades, hearts, clubs or diamonds?

Make fractions with the numbers on the spades and clubs as the numerators and the numbers on the diamonds and hearts as the denominators.

Station I – Have swatches of cloth available. Students look completely through this packet of material and make fractions using the total number of pieces of material as the denominator and each of the following as the numerator: (1) solid colored pieces, (2) some white in it, (3) flowered pieces and (4) some green in it.

Teacher-directed activity: Show students how to make equivalent fractions. Problems that have been mimeographed will be provided for practice.

Teacher-directed activity: How to add fractions with a common denominator. Problems will be provided for practice.

Station J – Add Like Fractions. Materials used: centimeter rods. You are to find:

- Two rods of the same color that will be as long as the red rod. Each rod is to be called  $\frac{1}{2}$ .
- Three rods of the same color that will be as long as the light green rod. Each one will be called what?
- Now do:
  1. Light green is what part of blue ( $\frac{1}{3}$ ).
  2. Light green + light green =  $\frac{1}{3} + \frac{1}{3} = \frac{2}{3}$ .
  3. Light green + light green + light green =  $\frac{1}{3} + \frac{1}{3} + \frac{1}{3} = \frac{3}{3}$ .
  4. Orange is what part of red ( $\frac{1}{2}$ ).
  5. Orange + orange + orange =  $\frac{1}{2} + \frac{1}{2} + \frac{1}{2} = \frac{3}{2}$ .
- See if you can make up some exercises similar to the one above.

Station K – Adding Like Fractions Using Unifix Blocks

- Get some unifix blocks and hook together four blocks and call the train “1,” find “ $\frac{1}{2}$ ” of the train and hook blocks together that show “ $\frac{1}{2}$ ” and  $\frac{1}{2} + \frac{3}{2}$  by hooking two blocks together to represent each half and write (     +     ) =  $\frac{1}{2} + \frac{3}{2} = \frac{4}{2}$  and make other trains to represent “1” – then find the sums of thirds, fourths, sixths and eighths. Follow the examples above.

Station L – Comparing Fractions Using Clay

- Make a ball of clay.
- Make another ball of clay that is  $\frac{1}{2}$  size of the first ball.
- Make a third ball of clay that is  $\frac{1}{3}$  the size of the first.
- Make a fourth ball that is one fourth the size of the first ball.
- Weigh to find which is the heavier: 1 or  $\frac{1}{2}$ ,  $\frac{1}{2}$  or  $\frac{1}{3}$ ,  $\frac{1}{4}$  or  $\frac{1}{2}$  and  $\frac{1}{4}$  or  $\frac{1}{3}$ .

Teacher-directed activity: have a discussion of how to change an improper fraction to a mixed fraction. Exercises are provided to help with this skill.

Teacher-directed activity: have a discussion of how to change a mixed fraction to an improper fraction. Activities for practice are provided.

Station M – Use a Picture of a Cheeseburger Platter. Based on the picture answer these questions about the meal using fractions:

- What part of it is meat?
- What part of the meal are the onions?
- What part of the meal is made up of cheese?
- What part of the meal is made up of the bread?

Station N – Read the articles clipped from the newspaper and tell me where in the newspaper you would find them. Remember fractions are used.

Teacher-directed activity: Show students how to add fractions with different denominators. Masters will be provided for practice.

Teacher-directed activity. Discuss how to subtract fractions with different denominators. Masters will be provided for practice.

Station O – 9 3 6 2 5.

Choose the number above that you want to be the denominator and use the other four numbers as the numerator. Make the fractions, then add them two at a time.

Example: My denominator is 5 and here are my fractions:  $9/5$ ,  $3/5$ ,  $6/5$  and  $2/5$ .

Here are my problems:

$$9/5 + 3/5 = 12/5$$

$$3/5 + 6/5 = 9/5$$

$$9/5 + 6/5 = 15/5$$

$$3/5 + 2/5 = 5/5$$

$$9/5 + 2/5 = 11/5$$

$$6/5 + 2/5 = 8/5$$

Now you choose one!

Station P – 5 3 2 4 7 8.

Choose the number above that you want to be the denominator and use the other five numbers as the numerator. Make the fractions, then subtract them two at a time – use the fraction with the larger numerator first.

Example: My denominator is 7, and here are my fractions:  $5/7$ ,  $3/7$ ,  $2/7$ ,  $4/7$ ,  $8/7$ .

Here are my problems:

$$5/7 - 3/7 = 2/7$$

$$3/7 - 2/7 = 1/7$$

$$5/7 - 4/7 = 1/7$$

$$5/7 - 2/7 = 3/7$$

$$4/7 - 2/7 = 2/7$$

Now you choose one!

Go to Station Q and listen to the tapes on addition and subtraction of fractions with common and uncommon denominators.

Go to Station R and work out the scramblegram of words used pertaining to all the operations on fractions and all terminology relating to fractions.

Go to Station S and use the instructions and directions to make a raceway.

Each student is to make a poster pertaining to uses of fractions.

### SAMPLE UNIT MODEL : THREE-LEVEL STUDY GUIDE

The following is a three-level study guide to help students read and think through reading an Algebra I reading (word) problem. At the beginning of studying word problems, it may be advisable to help many students separate necessary from unnecessary information. Reading predicts anticipated outcomes, and mathematics affirms the prediction. Too often students do not grasp the formula for selecting corection information to process the appropriate problem-solving skill.

#### *Algebra I – Distance Problems:*

A ship must average 22 miles per hour to make its 10-hour run on schedule. During the first four hours, bad weather caused it to reduce its speed to 16 miles per hour. What should its speed be for the rest of the trip to keep the ship to its schedule?

- Complete the following statements.

The scheduled length of time the run is \_\_\_\_\_ .  
The ship's average speed for the run is to be \_\_\_\_\_ .  
The ship was forced to travel at a reduced speed for \_\_\_\_\_  
\_\_\_\_\_ hours.  
During the bad weather, the ship averaged \_\_\_\_\_ .

- Circle the correct answers.

The entire trip will cover  
a. 64 mi.      b. 160 mi.      c. 220 mi.

During the first four hours, the ship traveled  
a. 88 mi.      b. 64 mi.      c. 22 mi.

After the bad weather, the time remaining to complete the trip on schedule will be  
a. 10 hrs.      b. 6 hrs.      c. 4 hrs.

The distance still to be traveled after the bad weather is  
a. 60 mi.      b. 156 mi.      c. 160 mi.

- Use the answers to the questions above to solve the problem here.
- What can you say if the ship's maximum speed is 25 mph?
- If the ship went 25 mph for the first four hours, could you say anything about the answer to the problem before you begin to calculate?

# 21 Reading and Home Economics

Home economics is no longer baking or sewing class exclusively. Today's home economics classrooms are filled with students eager to learn home management techniques, child development, personal development and family-social relationships, foods and nutrition, consumerism, clothing and textiles, and interior design and selection. The role of the home economist is equally matched in both manipulative and verbal skills. Not the least of the verbal skills is reading. Reading to learn is the crucial test of the contemporary student pursuing any of the areas of home economics.

## A. LOCATION SKILLS

1. **Use of the Text.** At one time a textbook educated the student in home economics. In many schools texts are being replaced by newspapers, pamphlets, magazines, occasional writings, advertising booklets and many other print or visual materials. Textbooks need to be taught early. Here are some suggested topics to help students find information in the text.

- Title, author and publisher
- Copyright date
- Table of contents
- Chapter headings
- Chapter subheadings
- How to read graphs and charts
- Picture captions
- Index

For many students calling attention to the titles of the chapters serves as an initial skimming of the book.

2. **Periodic Literature.** Since many curriculums have elected to study consumable materials in the form of pamphlets, etc., the student needs to know why and how the pamphlet comes into being. The purpose may be to inform, persuade, sell or remind. Is there a product involved? What are the claims made for the product? Is there a service involved? Who are the persons being served? Is there a gimmick involved? How much will it really cost?

These questions and many like them overlap in consumer classes, textile or fabric classes and foods and nutrition classes.

3. **Critical Reading.** Critical reading is not the only technique students may use in approaching reading in home economics. Certain words need to be recognized in specialized areas. Vocabulary devices such as structured overviews might be used to establish unfamiliar vocabulary words and to place them in appropriate relationships with one another. It would be appropriate for teachers to preread selections and select key words which reflect the important concepts to be used. (See the English section for a more detailed account.)

## B. VOCABULARY

### 1. Key Words

Society  
People  
Unwanted pregnancy  
Food  
    Malnutrition  
    Hunger  
    Starvation

Problems  
Uncontrolled reproduction  
Increased Awareness  
Natural resources  
Space  
    Tensions  
    Crowding

The words one uses attract and hold attention. The student must be familiar with key concept words in their reading. The teacher has a responsibility to discuss the words and the concepts. Other words seem the same, but to the buying public they are set out to "Bring in the Money."

#### Sample Model: Bulletin Board – Sale. Sale! Sale?

As in critical reading, the emotional impact must be discussed. Does "sale" really mean "sale?" Has the store upped the prices originally in order for them to reduce prices? What are "second week inflation fighters?" Is one more likely to go to a store that has "Door Busters" than to a store without or with "Just What You Wanted . . . At Big Savings" in large letters? Students who can "read" into such shams are much further ahead in concept learnings than those attracted by a sale sign. The following are examples of words that must be read critically.

Blockbusters	Drastic Reduction	\$1,000,000 Clearance
Super Savers	Big Savings	Back-to-School Discounts
Goin' Back to School Sale!	Save Big	Back to School Bonanza
Door Busters	Second Week Inflation Fighters	Wise Buys
Educated Buys	Just What You Wanted	Special
	. . . At Big Savings	

2. **Vocabulary in Following Directions.** Another place where vocabulary is important is in following or giving directions. One should be precise in following a recipe or a pattern.

#### SAMPLE MODEL: FOLLOWING DIRECTIONS – A DIRECTIONS GAME

Follow the directions listed below:

1. Read all of the directions before doing anything.
2. Write your name in the upper right hand corner of this page.
3. Write your teacher's name on the lower left hand corner of this page.
4. Write your school name on the upper left corner of this page.
5. Find a recipe for strawberry pie.
6. Ask the principal if you may serve the pie in the teacher's lounge. You may quietly go to the door.
7. When you get to the door shout to the teacher, "My name is Harvey Strawberry!"
8. Cover your ears when you sneeze.
9. Clap your hands twice for service.
10. Now that you have read all the directions, aren't you proud you read before you did all those activities.

Part of the fun of homemaking is discovery. Here is a vocabulary reinforcement exercise that can be enjoyed and others made for different occasions:

**Precise Words**

We ate two hamburgers,  
a sack of french fries,  
and a large sundae.  
2 cups of milk  
walked four blocks  
 $\frac{1}{4}$  of a 9-inch pie  
13 boys went

**Vague Words**

We ate a lot.  
some milk  
ran a ways  
piece of pie  
several boys went

3. **Word Maze.** Guiding students in their reading is especially important as one has to sequence activities. (See the English section concerning pattern guides.) The order of clue words should be called to the attention of the students. First, they must identify the fabric; second, they must determine the durability, and third, they must estimate the cost.

Other activities which are good for vocabulary and concept reinforcement are crossword puzzles. Most can be tailor-made for a particular unit and some are available commercially every month in periodicals like *What's New in Home Economics* and the *Illinois Teacher for Contemporary Roles*.

Find and circle the names of vegetables among the letters below. Can you find all 12?

B O C A R R O T O B E C L E  
E R A O F N N O W O P C X D  
A S P I N A C H P P V U Y M  
L E R I B E O R E O X D C A  
A F A C O V R T A T C W U B  
B Y D B N T E O S A E E Y Z  
S U I R I I N C L T T Q I C  
B V S X O N W R T O M A T O  
E F H K N U T D S T B R Y R  
E P B R O C C O L I Y M O N  
T A L M O E P C A B B A G E  
H P U R L E T T U C E U E U

Y T S C I S S O R S Y I O U T P  
E F I E L D L D E W R I V P E N  
L L A U G H O I D O R Z E X T T  
L U L W I T I R D U E Y E Y E S  
O B C L I F T H P O O L C A R I  
W I N D O W I E F X M N E A T N  
H O A Y J O U A X Q J I S I T G  
A Y T E U T E D R E A M M W Y L  
T P I C M R W T Y D N V A A U E  
R U O T P W X E Z Q U I P R Y O  
V R N B A C K R E A D I N G R U  
G D F D R U P M F R E Q U E N T  
C U T E V P T O E M V V C E I M  
L E D U C A T E O Y S I L L V  
P E V S Z T V O R A N G E O R B

4. **Mini-Dramas.** Another language activity which stems from reading or observations are mini-dramas. Role playing and problem solving are integral aspects of family and society relationships. "How to act on a date" could be the topic for class discussion or lecture, but many classes find that teenagers "read" improvised incidents and react in natural, appropriate behavior. The desired behavior is not abstracted by talking about it until after the students had a chance to "try on" a behavior. Most girls sympathize with a boy as he fumbles for money only to find he has left his wallet at home, or refrain from talking too glowingly about the prom in front of Joan who will not be going. Mini-situations for improvised role playing abound in most curriculum guides for home economics. Scripts for playlet situations are usually available for the students to read, act out and react to.
- C. **LEARNING PACKETS.** Individualized learning packets can be tailor made for reading. Because the packets are self-pacing, the student must be able to follow directions and have key concepts clearly explained. A number of such packets are available from the Home Economics Education Association, National Education Association, 1201 16th St., NW, Washington, D.C. 20036, for \$1.25. In the *Home Economics Education Package: Selection of Furniture*, there is a teacher's section. The student's section includes the following:
1. Pretest
  2. Learning objectives
  3. Lesson 1. Various styles of furniture available. The student must read six articles and find pictures of different styles and label them. There is a self-test in the form of a crossword puzzle.
  4. Lesson 2. Factors to be considered in buying wood furniture. The student is asked to read 10 articles, make wood samples and have someone demonstrate one aspect of woodworking. There is a self-test which is a matching exercise.

The remainder of the package is filled with activities and selections for reading. In each case, activities are preceded by reading.

The result of learning to read home economics material is reading to learn. The modern homemaker-wage earner has more to know than ever before and more to recognize in the field of self awareness. The following are some additional activities which might bring the use of language to a conscious level on the part of the student.

**SAMPLE MODEL: WHAT IS YOUR SLOGAN READING QUOTIENT (R.Q.)? \***

1. "The great American chocolate bar."
2. "We try harder."
3. "It's fluffy, not stuffy."
4. "When it rains it pours."
5. "The un-cola."
6. "The taste people hate twice a day."

\*Developed by I.G. Butler, Texas Tech University, Lubbock, Tex.



7. "You get more with a \_\_\_\_\_."
8. "The dog kids love to bite."
9. "They're smaller, but they're stronger."
10. "One of life's simple pleasures."
11. "Good to the last drop."
12. "Tastes like somebody's mom just made um."

Answers to Slogan R.Q. Quiz:

	<i>Score</i>	<i>R.Q.</i>
1. Hershey	10-12	Excellent
2. Avis	8- 9	Good
3. Three Musketeers	6- 7	Fair
4. Morton's Salt	3- 5	"Tune in"
5. 7-Up	0- 2	"Wake up"
6. Listerine		
7. Kenmore		
8. Armour Hotdog		
9. Phillips Milk of Magnesia		
10. Van Camps Pork & Beans		
11. Maxwell House Coffee		
12. Hunt's Snak Pak Pudding		

**D. ACTIVITIES\***

**SAMPLE ACTIVITY: CONSIDER**

Number of Players: 2-4

Parts: Product cards (skis, dog, clothes, records, etc.) and consideration cards (protection, grooming, recreation)

Deal: 4 consideration cards and 1 product card

Playing Directions. After dealing, in turn, decide whether you have consideration cards (resources, values and intended uses) which relate to your product card. If not, you may draw and discard either a consideration card or a product card.

\*Developed by Phyllis Smith, Home Economics, Purdue University

When you think you have a product and *three* consideration cards that are related, you may lay them down in front of you. Your opponents may challenge, and if justified, you pick up your cards, take a 15-point fine and proceed. If their challenge is unjustified, then they receive a fine of 15 points, and you win the round.

Score: Winner receives point value of product minus any fines received. Losers deduct point value of product they are holding plus fines received.

#### SAMPLE ACTIVITY: THINK TANK

The game judge or teacher will hand out one game card for each group of five students. Each card has one problem. Your group should write as many solutions for the problem as possible within six minutes. At the end of six minutes, count the number of alternatives you have and give your team one point for each.

Trade cards with another group. Read this problem. Mark a heavy line on the tally sheet and then add as many alternatives to the sheet as you can within six minutes. You will have one minute to recheck your list with the alternatives which the first group had written. Be sure that you do not have any of the same ones which they had. Give your team two points for each alternative you added.

Each group should read their problem and alternatives to the entire class. Anyone who can think of another solution will get three points for his group.

#### SAMPLE ACTIVITY: WORD SCRAMBLE

GINTTIF

FITTING

RAMGINK

MARKING

SERGNISIP

PRESSING

GINEMHM

HEMING

WISNEG

SEWING

TUITGNC

CUTTING

178

206

GNSTHITIC

STITCHING

GOAL – GARMENT

Unscramble the seven words above allowing one letter to each square. The unscrambled words describe essential steps in clothing construction. Now arrange the shaded letters to form the surprise word which describes the product of clothing construction efforts.

SAMPLE ACTIVITY: CROSSWORD PUZZLE

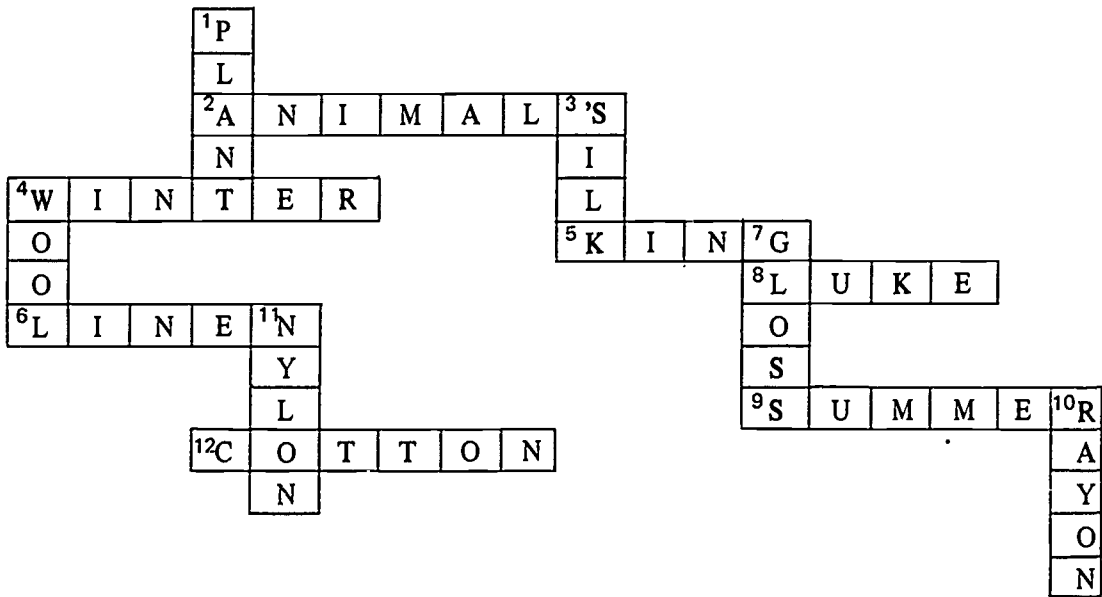

Down:

- 1. A source of natural fibers
- 3. A fiber produced by a worm
- 4. A fiber produced by sheep
- 7. Satin has a
- 10. Man-made fiber replaced by nylon
- 11. A popular man-made fiber

Across:

- 2. Several sheep
- 4. When coats are worn
- 5. Cotton is
- 6. Comes from flax
- 8. Temperature for washing
- 9. When to wear linen
- 12. A common natural fiber

## SELECTED REFERENCES

*Selection of Furniture*, Home Economics Education Association, National Education Association, Washington, D.C.

*Illinois Teacher for Contemporary Roles, Home Economics Education*, University of Illinois, Urbana. Published six times a year.

*Preparation for a Dual Role: Homemaker - Wage Earner*, Final Report, U.S. Department of Health, Education and Welfare, February, 1970.

*Selection of Window Treatments*, Home Economics Education Association, National Education Association, Washington, D.C.



<i>Title</i>	<i>Listen</i>	<i>WP</i>	<i>WM</i>	<i>Lit</i>	<i>Crit</i>	<i>Rate</i>	<i>Cont</i>	<i>Comments</i>
<i>Allyn and Bacon</i>								
A Cavalcade of American Writing			X	X	X		L	HS/DP
A Cavalcade of British Writing			X	X	X		L	HS/DP
A Cavalcade of Life in Writing			X	X	X		L	HS/DP
A Cavalcade of World Writing			X	X	X		L	MS, HS/DP
High Trails	X	X	X					MS/DP
Widening Views	X	X	X					MS/DP
<i>American Book Co.</i>								
High School Reading Books I and II			X	X	X			HS/DP
Reading Skill Books			X	X	X			MS/DP
<i>American Education Publications</i>								
Reading Success Series		X	X	X				MS, HS/C
Know Your World	X	X	X	X	X			MS, HS/C
You and Your World	X	X	X	X	X			HS/C
<i>Paul S. Amidon and Associates</i>								
Listen: Hear	X	X	X	X	X			MS/DP, C Laboratory Kit
<i>AMSCO School Publications</i>								
Vocabulary for the High School Student	X	X						HS/DP
<i>Appleton-Century-Crofts</i>								
Improving Reading Ability		X	X			X		HS/DP

<i>Title</i>	<i>Listen</i>	<i>WP</i>	<i>WM</i>	<i>Lit</i>	<i>Crit</i>	<i>Rate</i>	<i>Cont</i>	<i>Comments</i>
<i>Associated Educational Services Corp.</i>								
A Man Who Had No Eyes			X	X	X		L	MS, HS/DP
A Slander			X	X	X		L	HS/DP
The Short Story as a Listening Form			X	X	X		L	HS/DP
Split Cherry Tree			X	X	X		L	MS/DP
The Birds			X	X	X		L	HS/DP
The Form of the Sword			X	X	X		L	HS/DP
The Freshest Boy			X	X	X		L	HS/DP
The Monkey's Paw			X	X	X		L	MS, HS/DP
<i>Baldrige Reading Instruction Materials, Inc.</i>								
Technique Application Sheet								HS/DP Study Techniques
Reading and Study Techniques for Academic Subjects							L M Sc SS	HS/DP Study Techniques
Introductory Technique Application Sheet								HS/DP Study Techniques
<i>Barnell Loft, Ltd. and Dexter Westbrook, Ltd.</i>								
Basic Word Sets		X	X					MS/C
Specific Skills Series	X	X	X	X	X			MS, HS/DP
Supportive Reading Skills	X	X	X	X	X			MS, HS/DP
<i>Benefic Press</i>								
Thinking Box					X		L M Sc SS	MS, HS/DP

<i>Title</i>	<i>Listen</i>	<i>WP</i>	<i>WM</i>	<i>Lit</i>	<i>Crit</i>	<i>Rate</i>	<i>Cont</i>	<i>Comments</i>
<i>Better Reading Program, Inc.</i>								
Rapid Reading Kit				X		X		MS, HS/DP
<i>Book-Lab, Inc.</i>								
Kip Reader			X	X				MS, HS/C
Young Adult Sequential Reading Lab.	X	X	X	X				MS, HS/C
<i>College Skills Center</i>								
88 Passages to Develop Comprehension				X	X			HS/DP
100 Passages to Develop Comprehension				X	X			HS/DP
How to Develop a College Level Vocabulary			X					HS/DP
<i>Communacad</i>								
Word Craft 1, 2, 3			X					MS/DP HS/C
<i>Coronet</i>								
Listening With a Purpose	X							MS, HS/DP 12 cassettes, workbook
<i>Curriculum Research Associate</i>								
Reading as Thinking-Paragraph Comprehension				X	X			HS/DP
<i>Developmental Reading</i>								
Developing Reading Efficiency			X	X	X	X		HS/DP
Maintaining Reading Efficiency			X	X	X	X		HS/DP



<i>Title</i>	<i>Listen</i>	<i>WP</i>	<i>WM</i>	<i>Lit</i>	<i>Crit</i>	<i>Rate</i>	<i>Cont</i>	<i>Comments</i>
<i>EMC Corp.</i>								
Sports Close-Ups 1 and 2		X	X	X				MS/DP 11 cassettes, spirit masters
<i>Educational Developmental Laboratories</i>								
EDL Study Skills Library					X		Sc SS	MS/DP
<i>Educational Development Laboratories</i>								
Listen and Read	X			X				MS, HS/DP Audiotapes include study skills
Skimming and Scanning Program						X		HS/DP
Word Clues		X	X					MS, HS/DP
Reading 300	X	X	X	X	X	X	Sc SS	MS, HS/DP Includes above items
Comprehension Power Development				X	X			MS/DP Filmstrip series
<i>Educational Progress Corp.</i>								
Audio-Reading Progress Laboratory: Levels 7 and 8		X	X	X	X		LM Sc SS	MS/DP 25 audio tapes included
Clues to Reading Progress	X	X	X	X				MS, HS/C 36 audio cassette
Continuous Progress Laboratories: Series 700 and Series 800		X	C	C	C			MS/DP 14 audio cassette

185

<i>Title</i>	<i>Listen</i>	<i>WP</i>	<i>WM</i>	<i>Lit</i>	<i>Crit</i>	<i>Rate</i>	<i>Cont</i>	<i>Comments</i>
The Listening Progress Laboratory-Advanced	X	X	X	X				HS/C audio cassettes included
The Listening Progress Laboratory-Series 7, 8, 9	X							MS/C audio cassettes included
<i>Educators Publishing Service</i>								
A Vocabulary Builder Series		X	X					MS, HS/DP
Efficient Study Skills							L Sc SS	HS/DP
The Structure of Words		X	X					MS, HS/C
Word Attack Manual		X	X					MS/DP
<i>Educational Record Sales</i>								
Building Verbal Power in the Upper Grades	X		X	X				MS/DP 5 records
Sound Skills for the Upper Grades		X						MS/DP 9 filmstrips
<i>Eye Gate House, Inc.</i>								
Advanced Reading Skills	X		X	X				MS/DP 10 filmstrips
Fundamentals of Vocabulary Building		X	X					MS/DP 9 filmstrips

<i>Title</i>	<i>Listen</i>	<i>WP</i>	<i>WM</i>	<i>Lit</i>	<i>Crit</i>	<i>Rate</i>	<i>Cont</i>	<i>Comments</i>
<i>Field Educational Publications</i>								
Cyclo-Teacher Learning Aid School Kit		X	X					HS/DP Programmed instruction, study skills
Happenings				X				MS, HS/C
The Americans All Series				X				MS/C
The Deep Sea Adventure Series				X				MS/C
The Kaleidoscope Readers			X	X				MS, HS/C
The Morgan Bay Mysteries				X				MS/C
The Reading Motivated Series				X				MS/C
<i>Checkered Flag Series</i>				X				Study skills MS/C
Checkered Flag Classroom Audio-Visual Kits	X							MS/C Filmstrips and tapes
<i>Follett Publishing Co.</i>								
Success With Language		X	X	X				MS/DP HS/C
Turner Livingston Communication Series		X	X	X				HS/C
<i>Garrard Publishing Co.</i>								
Consonant Lotto	X	X						MS, HS/C Game

<i>Title</i>	<i>Listen</i>	<i>WP</i>	<i>WM</i>	<i>Lit</i>	<i>Crit</i>	<i>Rate</i>	<i>Cont</i>	<i>Comments</i>
Group Sounding Game	X	X	X					MS/C
Read and Say Verb Game	X	X	X	X				MS, HS/C
The Syllable Game	X	X						MS, HS/C
Vowel Lotto	X	X						MS, HS/C Game
<i>Ginn and Co.</i>								
Ginn Basic Reading Program		X	X	X	X			MS/C
Reading 360		X	X	X	X			MS, HS/C
Word Enrichment Program Levels 3-7		X						MS, HS/DP
<i>The Globe Book Co.</i>								
Programmed Reading				X	X			MS/DP
<i>Grolier Educational Co.</i>								
Reading Attainment Systems	X	X	X	X				HS/C
<i>C.S. Hammond and Co.</i>								
Building Reading Confidence	X	X	X	X				MS/DP
Words Are Important		X	X					MS, HS/DP
<i>Harcourt, Brace and Jovanovich</i>								
Adventures in Literature		X	X	X	X		L	MS, HS/DP
Design for Good Reading A, B, C, D		X	X	X	X			HS/DP

<i>Title</i>	<i>Listen</i>	<i>WP</i>	<i>WM</i>	<i>Lit</i>	<i>Crit</i>	<i>Rate</i>	<i>Cont</i>	<i>Comments</i>
Speech to Print Phonics	X	X						MS, HS/C
The New World Series		X	X	X	X		L	MS/DP
Word Attack: A Way to Better Reading	X	X	X					HS/C
Word Analysis Practice Sets A, B, C		X	X					MS, HS/DP
<i>Harper and Row, Inc.</i>								
Design for Reading Levels 17-20		X	X	X	X		M Sc SS	MS/DP
Scope/Reading			X	X				MS, HS/C six titles
Word Clues		X	X					HS/DP
<i>D.C. Heath and Co.</i>								
A Matter of Nerve: Heath Urban Reading Program			X	X				MS/C 3 filmstrips, 3 records, and spirit masters
Efficient Reading, Revised			X	X	X			HS/DP
Efficient Reading Revised Form A			X	X	X			HS/DP
Guide to Effective Reading		X	X	X	X	X		HS/DP
Making a Difference: Heath Urban Reading Program			X	X				MS/C 3 filmstrips, 3 LP records, spirit masters

<i>Title</i>	<i>Listen</i>	<i>WP</i>	<i>WwI</i>	<i>Lit</i>	<i>Crit</i>	<i>Rate</i>	<i>Cont</i>	<i>Comments</i>
Time to Think: Heath Urban Reading Program			X	X				MS/C 3 filmstrips, 3 LP records, spirit masters
Toward Reading Comprehension		X	X	X	X	X		HS/DP
Winning Words		X	X					MS, HS/DP
<i>Holt, Rinehart and Winston</i>								
Holt's Impact Series			X	X				MS/DP Includes record
Increasing Reading Efficiency		X	X	X	X			HS/DP
Realizing Reading Potential		X	X	X	X			HS/C
Word Wealth		X	X					HS/DP
Word Wealth Junior		X	X					MS/DP
<i>Houghton-Mifflin Co.</i>								
Houghton-Mifflin Action Series		X	X	X				MS, HS/C
Reading for Enjoy- ment Series		X	X	X	X			MS/DP
Riverside Reading Series		X	X	X	X			MS, HS/DP
Trouble Shooter	X	X	X	X				MS, HS/C
<i>Jamestown Publishers</i>								
Six-Way Paragraphs			X	X	X			MS, HS/DP

<i>Title</i>	<i>Listen</i>	<i>WP</i>	<i>WM</i>	<i>Lit</i>	<i>Crit</i>	<i>Rate</i>	<i>Cont</i>	<i>Comments</i>
<i>Laidlaw Bros.</i>								
Study Exercises for Developing Reading Skills		X	X	X	X			HS/DP
<i>Learn Inc.</i>								
Communication Through Effective Reading		X	X	X	X			MS/DP
Rapid Comprehension Through Effective Reading		X	X	X	X			HS/DP
<i>Learning Materials, Inc.</i>								
Literature Sampler		X	X	X	X		L	MS/DP Laboratory Kit
<i>Lippincott</i>								
Reading for Meaning			X	X				MS, HS/DP nine books
<i>Lyons and Carnahan</i>								
Phonics We Use Levels C through G	X	X	X					MS/C
Phonics We Use Game Kit	X	X	X					MS/C
<i>McGraw-Hill</i>								
Critical Reading Improvement					X			HS/DP
Vocabulary Improvement			X					HS/DP
<i>The Macmillan Co.</i>								
Advanced Skills in Reading 1, 2, and 3			X	X	X			MS, HS/DP

<i>Title</i>	<i>Listen</i>	<i>WP</i>	<i>WM</i>	<i>Lit</i>	<i>Crit</i>	<i>Rate</i>	<i>Cont</i>	<i>Comments</i>
Audio-Lingual English	X	X	X	X				HS/C 230 audio tapes, six workbooks
Decoding for Reading	X	X						MS/C 16 LP records, 2 workbooks
<i>Charles E. Merrill Books, Inc.</i>								
Improve Your Reading Ability		X	X	X	X			HS/DP
New Modern Skilltext Series		X	X	X	X <sup>o</sup>			MS/DP
<i>Oxford Book Co.</i>								
Building Word Power		X	X					HS/DP
Enriching Your Vocabulary		X	X	X				HS/DP
Reading Comprehension Workshop			X	X	X			HS/DP
Vocabulary Workshop		X	X	X				HS/DP
<i>Perceptual Developmental Laboratories</i>								
Advanced Reading			X	X		X		HS/DP 10 films
Comprehension Skill Development				X				MS, HS/C
<i>Perceptual Development Laboratories</i>								
Developmental Reading		X	X	X		X		MS/DP Includes tachistoscope practice
Intermediate Reading		X	X	X		X		MS, HS/DP



<i>Title</i>	<i>Listen</i>	<i>WP</i>	<i>WM</i>	<i>Lit</i>	<i>Crit</i>	<i>Rate</i>	<i>Cont</i>	<i>Comments</i>
Reading and Writing With Phonics	X	X						MS, HS/C Includes films, film loops, tapes
Reading Improvement			X	X		X		MS/DP Includes films
Vocabulary Book		X	X					MS/C Includes films
<i>Prentice-Hall, Inc.</i>								
Be a Better Reader: Foundations, A, B, C		X	X	X	X		Sc SS L M	MS/DP
Be a Better Reader Series I through VI		X	X	X	X		Sc SS L M	MS, HS/DP
Building Your Vocabulary		X	X					HS/DP
Increase Your Vocabulary		X	X					HS/DP
Words in Action		X	X					MS/DP
<i>Polaski Co.</i>								
The Reading Line				X	X		L M Sc SS	HS/DP
<i>Random House, Inc.</i>								
Random House Reading Program Green, Blue, Tan, Olive		X	X	X	X			MS/DP
<i>Reader's Digest Services, Inc.</i>								
Adult Readers		X	X					MS, HS/C
Grow in Word Power			X	X		X		MS/DP
Help Yourself to Improve Your Reading Levels 1-4			X	X		X		MS, HS/DP

<i>Title</i>	<i>Listen</i>	<i>WP</i>	<i>WM</i>	<i>Lit</i>	<i>Crit</i>	<i>Rate</i>	<i>Cont</i>	<i>Comments</i>
New Reading Skill Builder Kit		X	X	X	X			MS/DP Includes 8 audio tapes, 46 books
<i>The Reading Laboratory, Inc.</i>								
Skill File		X	X	X	X			MS, HS/DP
The News Read Series			X	X	X			MS/DP HS/C
<i>Schloat Productions, Inc.</i>								
Fantastic Fables		X	X	X	X			MS/C 4 audio cassettes, 4 film strips, 4 stories 30 comic books
<i>Scholastic Magazines, Inc.</i>								
Creative Teaching Kits				X	X			MS, HS/DP Includes record, spirit masters, photo pack, mobile
Double Action		X	X	X				MS/DP HS/C
Go			X	X	X		L M Sc SS	MS/DP HS/C
Pattern for Reading		X	X	X	X		L M Sc SS	MS, HS/DP
Poetry			X	X	X		L	MS/DP Includes record, 6 posters
Scope Skills		X	X	X	X			MS, HS/C
<i>Scholastic Magazines, Inc.</i>								
Scoposters and Scovisuals		X	X	X	X			MS, HS/C
The Action Kit		X	X	X				MS, HS/C Includes record

<i>Title</i>	<i>Listen</i>	<i>WP</i>	<i>WM</i>	<i>Lit</i>	<i>Crit</i>	<i>Rate</i>	<i>Cont</i>	<i>Comments</i>
The Action Libraries		X	X	X				MS, HS/C
The Scholastic Literature Units							L	MS, HS/DP
<i>Science Research Associates, Inc.</i>								
Better Reading Books				X		X		MS, HS/DP
College Reading Program I and II			X	X	X			HS/DP
Cracking the Code		X	X					MS/C
Design for Reading I and II			X	X	X	X		MS/DP HS/C
Developing Your Vocabulary		X	X					HS/DP
Dimensions: American Album				X			SS	MS, HS/DP
Dimensions: Man Power and Natural Resources				X			SS	MS, HS/DP
Dimensions: We Are Black			X	X			SS	MS, HS/C Includes 2 LP records, 4 film-strips
Getting It Together			X	X	X			MS, HS/C
How to Become a Better Reader			X	X	X	X		HS/DP
How to Improve Your Reading			X	X	X	X		HS/DP
How to Read Creative Literature			X	X	X		L	HS/DP
How to Read Factual Literature				X				MS, HS/DP

<i>Title</i>	<i>Listen</i>	<i>WP</i>	<i>WM</i>	<i>Lit</i>	<i>Crit</i>	<i>Rate</i>	<i>Cont</i>	<i>Comments</i>
Learnings in Science			X	X	X		Sc	MS/DP
Multi Read II		X	X	X	X	X		HS/C
Pilot Library Series				X				MS/DP
Reading for Understanding Junior, Senior, Advanced			X	X	X			MS, HS/DP, C
Reading Laboratories IIc, IIa, IIIb, IVa		X	X	X	X	X		MS, HS/DP
Spelling Word Power Laboratory		X	X					MS/DP
Streamline Your Reading				X	X	X		HS/DP
Studying a Text Book				X	X			HS/DP study techniques
Vocabulab 3 Program		X	X					MS/DP includes LP record, 20 word wheels <sup>S</sup>
Word Study I and II		X	X					MS/DP, C
You Can Read Better			X	X	X	X		HS/DP
<i>Scott, Foresman and Co.</i>								
ACE 401	X	X	X	X	X			HS/DP
Basic Reading Skills for Junior High		X	X	X				MS/DP
Basic Reading Skills for Senior High		X	X	X	X			HS/DP
Better Work Habits								HS/DP study skill
Reading Skills and Text Book		X	X	X				MS/DP
Sounds of Spoken English	X	X	X	X				HS/DP includes cassette

<i>Title</i>	<i>Listen</i>	<i>WP</i>	<i>WM</i>	<i>Lit</i>	<i>Crit</i>	<i>Rate</i>	<i>Cont</i>	<i>Comments</i>
<i>Scott, Foresman and Co.</i>								
Tactics in Reading I, II, and III		X	X	X	X			HS/DP
Vocabulary Development Program		X	X					HS/DP 4 records
<i>Silver Burdett Co.</i>								
Building Your Language Power		X	X	X				HS/C
Success in Reading			X	X	X			MS/DP
<i>St. Martins Press, Inc.</i>								
Passport to Reading			X	X	X			MS/C
<i>Steck-Vaughn Co.</i>								
Reading Essentials: Progress in Reading		X	X	X				MS/DP
Reading Essentials: Mastery in Reading		X	X	X				MS/DP
Reading Essentials: New Goals in Reading		X	X	X				MS/C
<i>Teachers College Press</i>								
Gates-Pearson Reading Exercises Books A, B, C, D				X				MS/DP
McCall-Crabbs Standard Test Lessons in Reading Books A, B, C, D, E				X				MS, HS/DP
<i>Fern Tripp</i>								
Reading for Safety: Community Signs		X	X	X				MS, HS/C
I Want a Driver's License		X	X	X				HS/C

<i>Title</i>	<i>Listen</i>	<i>WP</i>	<i>WM</i>	<i>Lit</i>	<i>Crit</i>	<i>Rate</i>	<i>Cont</i>	<i>Comments</i>
<i>Webster Division, McGraw-Hill Co.</i>								
Conquests in Reading		X	X					MS/C
New Practice Readers				X	X			MS/DP
Programmed Reading for Adults		X	X	X				HS/C
Step Up Your Reading Power			X	X				MS, HS/C
The Magic World of Dr. Spello		X	X					MS/C
Vocabulary Improvement		X	X					HS/DP
Webster Classroom Reading Clinic	X	X	X	X	X			MS/C includes Dr. Spello, leisure titles, word wheels, sight word cards etc.
Vocab - 70		X	X					MS, HS/DP six workbooks
<i>Winston Press</i>								
Power Reading II		X	X	X	X			MS/DP HS/C
Power Reading III		X	X	X	X			HS/DP
<i>Word Games Publisher</i>								
Word Games - Book II		X	X					MS/DP
<i>Xerox Co.</i>								
The Way It Is			X	X	X			MS, HS/C

## B. MATERIALS FOR RECREATIONAL AND SUPPLEMENTARY READING

### 1. Series or Collections of High Interest/Low Readability Materials

Addison Wesley	Reading Development Series
Allyn and Bacon	Breakthrough
American Guidance Service	Coping with Series
Bantam Books	Bantam Perspective Series
Barnell Loft, Inc. (Dexter-Westbrook)	Incredible Series
Benefic Press	Mystery Adventure Series
Berkeley Books	World of Adventure Series
Bowmar	Tempo Books
Children's Press	Reading Incentive Series
Dell	"... and Hereby Hangs the Tale" Series
Ed-U Press	Laurel Leaf Library
Fearon	Mayflower Books
Field Educational Publications	Yearling Books
Follett	Comics on Drugs, Sex, Venereal Disease and Birth Control
Globe Book Co.	Pacemaker Series
Harper and Row	Americans All
Harr-Wagner	Checkered Flag Series
D. C. Heath	Deep Sea Adventure Series
Hertzberg New Method	Happenings
Holt, Rinehart and Winston	Kaleidoscope
Houghton Mifflin	Morgan Bay Mysteries
Learning Research Associates	Reading Motivated Series
Leswing Communications, Inc.	Interesting Reading Series
McGraw-Hill	<i>American Folklore</i>
Charles Merrill	<i>Four Complete Teen-Age Novels</i>
National Association for the Deaf	<i>Insight and Outlook</i> and other titles
New Dimensions in Education	American Adventure Series
Noble and Noble	Myths and Tales of Many Lands
Penguin Books	Paperback Classics
	Scope/Reading
	Reading Motivated Series
	Teen Age Tales
	General Collection of Interesting Topics
	Impact Series
	Directions
	Interact
	New Riverside Literature Series
	They Helped Make America
	Literature Sampler, Junior Edition
	Your Own Thing Series
	What Job for Me? Series
	Mainstream Books
	Classics for Low Level Readers
	Name of the Game
	Crossroads Series, Springboards
	Puffin Books

Pyramid Publications	Hi-Lo Books
Rand McNally	Voices
Random House/Singer	Alfred Hitchcock Mysteries
	Aware
	Challenger Books
	Gateways
	Green Interest Center
	Blue Interest Center
	Red Interest Center
	Landmark Books
	Landmark Giants
	Pro Basketball Library
	Punt, Pass and Kick
Scholastic Book Services	Action Libraries
	Arrow Books
	Biography
	Black Literature Program
	Contact
	Dogs, Horses, Wildlife
	Especially for Boys
	Especially for Girls
Scholastic Book Services	Ethnic Reading
	Fantasy
	Favorites Old and New
	Fun and Laughter
	History, History Fiction
	Making and Doing
	Modern Stories
	Mystery
	Myths and Legends
	People of Other Lands
	Pleasure Reading Libraries I and II
	Reluctant Reader Libraries
	Science
	Science and Fiction
	Scope Play Series
	Tab Books
Science Research Associates	An American Album
	Countries and Cultures Kit
	New Rochester Occupational Reading Series
	Pilot Libraries IIb, IIc, IIIb
	We Are Black
	Manpower and Natural Resources
	Something Else
Scott, Foresman	Call Them Heroes
Silver Burdett	Archway Paperbacks
Washington Square Press	Everyreader Series
Webster	Reading for Concepts
	Reading Incentive Series
	Reading Shelf I and II
Xerox	The Way It Is



## 2. Booklists for High Interest/Low Readability

*A Place to Start.* Robert Leibert. Lists thousands of titles appropriate to school subject areas, especially social studies. Annotation includes reading level, interest level, author and publisher. Reading Center, University of Missouri, 52nd and Holmes, Kansas City, Mo. 64110.

*Childrens Books for \$1.50 or Less.* Association for Childhood Education International, 3615 Wisconsin Av., NW, Washington, D.C.

*Fare for the Reluctant Reader.* Anita E. Dunn and others. Annotated list selected for junior and senior high readers. Books chosen to reflect teenage interests. Capitol Area School Development Association, Albany, N.Y., 1964.

*Gateways to Readable Books.* Ruth Strang and others. Annotated graded list on many topics for adolescents who find reading difficult. (4th ed.) Wilson, 1966.

*Good Reading for Disadvantaged Readers.* George Spache. Garrard, 1972.

*Good Reading for Poor Readers.* George Spache. Useful in elementary and junior high school. Garrard, 1972.

*High Interest - Easy Reading for Junior and Senior High School Reluctant Readers.* Raymond C. Emery, Margaret B. Houshower. National Council of Teachers of English (NCTE), 1965.

*High Interest - Easy Reading for Junior and Senior High School Students.* Compiled by Marian White. Most recent National Council of Teachers of English list, 1972.

*High Interest - Low Vocabulary Booklist.* Education Clinic, Boston University School of Education, 332 Bay State Road, Boston, Mass.

*Hooked on Books.* D. Fader and E. McNeil Berkeley, 1966.

*Mod-Mod Read-In Book List.* Fifty titles with one-line annotations prepared especially for black potential dropouts. Hertzberg New Method, Inc., Vandalia Road, Jacksonville, Ill.

"Offbeat Paperbacks for Your Classroom," by George J. Becker. *Journal of Reading* (November, 1971), pp. 127-129.

*Vocations in Biography and Fiction: An Annotated List of Books for Young People.* Kathryn A. Haebich. 1,070 titles, mostly biographies. Includes some titles of high interest, low reading level for grades 9-12. American Library Association (ALA), 1962.

## 3. Magazines

*American Girl.* Girl Scouts of America, 830 Third Av., New York, N.Y.

*Boy's Life.* Boy Scouts of America, New Brunswick, N. J.

*Calling All Girls.* Parent's Magazine Publications, Inc., Bergenfield, N.J.

*Children's Digest.* Parent's Magazine Publications, Inc., Bergenfield, N.J.

*Cricket.* Open Court Publishing Co., 1058 Eighth St., LaSalle, Ill. 61301

*Kids.* 747 Third Av., New York, N.Y. 10017.

*School Bulletin.* School Service, National Geographic Society, Washington, D.C. 20036.

*Nature and Science.* The Natural History Press, Garden City, N.Y.

*Newsweek.* Newsweek, Inc., 444 Madison Av., New York, N.Y. 10022.

*Read.* American Education Publications, Education Center, Columbus, Ohio 43216.

*Reader's Digest.* Reader's Digest Services, Pleasantville, N.Y. 10570.

*Scope.* Scholastic Book Services, 904 Sylvan Av., Englewood Cliffs, N.J. 07632.

*Seventeen.* 320 Park Av., New York, N.Y.

*Sport.* Sport Magazine, P.O. Box 5705, Whitestone, N.Y. 11357.

*Time.* Time-Life, Inc., Time and Life Building, Rockefeller Center, New York, N.Y.

*World Traveler.* 1537 35th St., NW, Washington, D.C. 20007.

#### 4. Newspapers

*Junior Review.* Civic Education Services Inc., 1733 K St., Washington, D.C. 20036.

*Know Your World.* American Education Publications Education Center, Columbus, Ohio 43216. Reading level for grades 2-3. Interest level for grades 5-12.

*New York, New York.* Random House, Inc., 201 E. 50th St., New York, N.Y. 10022. Reading level for grades K-8. Interest level for grades 5-12.

*News for You.* A and B Editions, Laubach Literary, Inc., Syracuse, N.Y. 13210. Edition A: reading level for grades 2-3. Interest level for grade 7-adult. Edition B: reading level for grades 3-4. Interest level for grade 7-adult.

*The New York Times.* Large Type Weekly, The New York Times Co., Times Square, New York, N.Y. 10036. Reading level for adults. Interest level for adults.

*You and Your World.* American Education Publications, Education Center, Columbus, Ohio 43216. Reading level for grades 3-5. Interest level for grades 9-12.

#### 5. Source Lists: Magazines/Newspapers

*Good Reading for Poor Readers.* George Spache, Garrard, 1972.

*Guide to Children's Magazines, Newspapers, Reference Books.* Roberta Bounerat, Association for Childhood Education International, 3615 Wisconsin Av. NW, Washington, D.C. 20016, 1968.

*Periodicals for School Libraries. A Guide to Magazines, Newspapers, Periodical Indexes.* Marian H. Scott, American Library Association, 1969.

6. **Games for Reading.** The following citations and publishers are excellent sources for reading games:

Jones, Linda, "Games, Games, Games – And Reading Class," *Journal of Reading*, Volume 15, Number 1, October, 1971, pp. 41-46.

Schubert, Delwyn G., and Torgerson, Theodore L., *Improving the Reading Program*, 3rd edition, William C. Brown Co., Publishers, Dubuque, Iowa, 1972.

Garrard Publishing Company, 1607 N. Market St., Champaign, Ill. 61820.

Word Games Publishers, P. O. Box 305, Healdsburg, Calif. 95448.

## C. SOURCES

### 1. Free and Inexpensive Teaching Materials

Aubrey, Ruth H., editor. *Selected Free Materials for Classroom Teachers.* Palo Alto, Calif.: Fearon Publishers, 1965. Order from: Fearon Publishers, Inc., 2165 Park Blvd., Palo Alto, Calif. 94306.

Educational Service Bureau of Dow Jones and Co., Inc. *List of Materials Available to Secondary School Instructors.* Princeton, N.J.: Dow Jones & Co., Inc. 1970-71. Order from: B. A. Schuler, Educational Service Bureau, Dow Jones and Co., Inc., Princeton, N.J. 08540.

Horkheimer, Mary Foley, and Deffor, John W., editors. *Educators Guide to Free Films.* 30th ed., Randolph, Wis.: Educators Progress Service, Inc., 1970. Order from Educators Progress Service, Inc., Randolph, Wis. 53956.

Horkheimer, Mary Foley, and Doffer, John W. *Educators Guide to Free Filmstrips*, 22nd annual ed., Randolph, Wis.: Educators Progress Service, Inc., 1970. Order from: Educators Progress Service, Inc., Randolph, Wis. 53956.

Jackson, Joe L., editor. *Free and Inexpensive Learning Materials.* 15th biennial ed. Nashville, Tenn.: Division of Surveys and Field Services, George Peabody College for Teachers, 1970. Order from: George Peabody College for Teachers, Division of Surveys and Field Services, Nashville, Tenn.

Marshall, Jane N., editor. *Free and Inexpensive Pictures, Pamphlets and Packets for Air/Space Age Education*, 6th ed. Washington, D.C.: National Aerospace Education Council, 1966. Order from: National Aerospace Education Council, 806 15th St., NW, Washington, D.C. 20005.

O'Hara, Frederic J. *Over 2,000 Free Publications, Yours for the Asking, Compiled and Edited by Frederic J. O'Hara*. New York: New American Library, 1968. (A Signet Reference Book). Order from: New American Library, Inc., P. O. Box 2310, Grand Central Station, New York, N.Y. 10017.

Note: This compilation places substantial reliance upon bulletins, pamphlets and documents produced by the U.S. Government Printing Office. Rather than being strictly free as one would infer from the title, many of them have a cost of 5 to 25 cents.

Salisbury, Gordon. *Catalog of Free Teaching Materials*. Riverside, Calif.: Rubidoux Printing Co., 1970. Order from: Catalog of Free Teaching Materials, P. O. Box 1075, Ventura, Calif. 93001.

*Sources of Free Teaching Aids*. Order from: Bruce Miller Publications, Box 369, Riverside, Calif. 92502.

*Sources of Teaching Materials*. Order from: Catherine Williams, Ohio University Press, Columbus, Ohio 43210.

Wagner, Guy, and Mork, Dorlan. *Free Learning Materials for Classroom Use*. An annotated list of sources with suggestions for obtaining, evaluating, classifying and using. Cedar Falls, Iowa: Extension Service, State College of Iowa, 1967. Order from: The Extension Service, State College of Iowa, Cedar Falls, Iowa.

Wittich, Walter A., and Suttles, Raymond H., editors. *Educators Guide to Free Tapes, Scripts, Transcriptions*.

## 2. Free Supplemental Materials for the Classroom

California Redwood Association  
617 Montgomery St.  
San Francisco, Calif. 94111

Forest Service  
U.S. Department of Agriculture  
Washington, D.C. 20250

Bureau of Mines  
U.S. Department of the Interior  
4800 Forbes Av.  
Pittsburgh, Pa. 15213

Bureau of Reclamation  
U.S. Department of the Interior  
Washington, D.C. 20240

Pendleton Woolen Mills  
Home Economics Department  
218 S.W. Jefferson St.  
Portland, Ore. 97201

U.S. Atomic Energy Commission  
Technical Information  
Oak Ridge, Tenn. 37830

John Hancock Mutual Life Insurance Co.  
200 Berkeley St.  
Boston, Mass. 02117

Fort Ticonderoga  
Education Services  
Attention: Mrs. Thomas Lape  
Box 390  
Ticonderoga, N.Y. 12883

Tennessee Valley Authority  
Information Office  
Knoxville, Tenn. 37902

Japan National Tourist Organization  
333 N. Michigan Av.  
Chicago, Ill. 60601

Australian News and Information Bureau  
636 Fifth Av.  
New York, N.Y. 10020

New Zealand Embassy  
19 Observatory Circle  
Washington, D.C. 20008

Canadian Government Travel Bureau  
Ottawa, Ont., Canada

Austrian Information Service  
31 E. 6th-9th St.  
New York, N.Y. 10021

Consulate General of Finland  
Equitable Life Building  
18th Floor, 120 Montgomery St.  
San Francisco, Calif. 94104

Embassy for the Union of  
Soviet of Socialist Republics  
Information Department  
1706 18th St., NW  
Washington, D.C. 20009

German Information Center  
410 Park Av.  
New York, N.Y. 10022

Italian Cultural Institute  
686 Park Av.  
New York, N.Y. 10021

Netherlands Information Service  
711 Third Av.  
New York, N.Y. 10017

Norwegian Embassy Information Service  
Norway House  
290 Madison Av.  
New York, N.Y. 10017

Polish Embassy  
Information Officer  
2640 16th St., NW  
Washington, D.C. 20009

United Nations  
Public Inquiries Unit  
Office of Public Information  
United Nations, N.Y.

Iranian Embassy  
Press and Information Department  
3005 Massachusetts Av., NW  
Washington, D.C. 20008

Israel Information Services  
11 E. 70th St.  
New York, N.Y. 10021

Eastman Kodak Co.  
Consumer Markets Division  
343 State St.  
Rochester, N.Y. 14650

Union Pacific Railroad Co.  
1416 Dodge St.  
Omaha, Neb. 68102

National Cotton Council of America  
P. O. Box 12285  
Memphis, Tenn. 38112

American Angus Association  
9201 Frederick Blvd.  
St. Joseph, Mo. 64501

American Brahman Breeders Association  
4815 Gulf Freeway  
Houston, Tex. 77023

Binney and Smith  
380 Madison Av.  
New York, N.Y. 10017

American Iron Ore Association  
600 Bulkey Bldg.  
Cleveland, Ohio 44115

Brown Shoe Co.  
Public Relations Department  
8300 Maryland Av.  
St. Louis, Mo. 63105

Alaska Railroad  
U.S. Department of the Interior  
P. O. Box 7-2111  
Anchorage, Alaska 99501

Lockheed Aircraft Corp.  
Department 06-03  
P. O. Box 551  
Burbank, Calif. 91503

Belgian Linen Association  
Promotion Center  
280 Madison Av.  
New York, N.Y. 10016

General Motors Corp.  
Public Relations Staff  
Room 1-101, General Motors Building  
Detroit, Mich. 48202

Animal Welfare Institute  
P. O. Box 3492  
Grand Central Station  
New York, N.Y. 10017

General Electric Missiles  
and Space Division  
Room 4C, Product Information  
P. O. Box 8555  
Philadelphia, Pa. 19101

Bureau of Indian Affairs  
U.S. Department of the Interior  
1961 Constitution Av., NW  
Washington, D.C. 20242

Secret Service  
U.S. Department of the Treasury  
1800 G Street, NW  
Washington, D.C. 20226

Department of Tourism  
State Capitol  
Any State

Florida Citrus Commission  
Institutional and School  
Marketing Department  
P. O. Box 148  
Lakeland, Fla. 33802

American Viscose Division  
FMC Corp.  
1617 John F. Kennedy Blvd.  
Philadelphia, Pa. 19103

Bausch and Lomb  
Rochester, N.Y. 14602  
(makes lenses, microscopes, binoculars)

Bulova Watch Company, Inc.  
630 Fifth Av.  
New York, N.Y. 10020

American Iron and Steel Institute  
150 E. 42nd St.  
New York, N.Y. 10017

### 3. Free Newsletters

*Active and Announced Price Support Programs  
Approved by the Board of Director of Commodity  
Credit Corporation*  
Commodity Credit Corporation  
Department of Agriculture  
Washington, D.C. 20250  
Monthly

*AECL Review*  
Atomic Energy of Canada, Ltd.  
Chalk River Nuclear Laboratories  
Chalk River, Ont.  
Canada  
Monthly

*AFL-CIO American Federationist*  
AFL-CIO  
815 16th St., NW  
Washington, D.C.  
Monthly

*African News Digest*  
Farrel Lines, Inc.  
1 Whitehall St.  
New York, N.Y. 10004  
Monthly

*Agriculture Abroad*  
Canada Department of Agriculture  
Sir John Carline Building  
Ottawa, Ont.  
Canada  
Bi-monthly

*Americans for Constitutional Action  
Congressional Record Digest and Tally*  
20 E Street, Suite 350  
Washington, D.C.

*American-Soviet Facts*  
National Council of American-  
Soviet Friendship  
1156 Fifth Av.  
New York, N.Y. 10010

*ASA News*  
Association for the Study of  
Abortion, Inc.  
250 W. 57th St.  
New York, N.Y. 10019  
Quarterly

*Atlantic Community News*  
Atlantic Council of the  
United States  
1616 H St., NW  
Washington, D.C.  
Monthly

*Bank Letter*  
First National Bank  
Dallas, Tex. 75222  
Monthly

*Barometer of Business*  
Harris Trust and Savings  
111 W. Monroe St.  
Chicago, Ill. 06090  
Monthly

*Bond and Money Market Review*  
First National Bank  
38 S. Dearborn St.  
Chicago, Ill. 60690  
Monthly

*Book*  
The Naylor Co.  
1015 Culebra Av.  
San Antonio, Tex. 78201  
Schools — free

*Borzio Quarterly*  
Alfred A. Knopf, Inc.  
501 Madison Av.  
New York, N.Y. 10022  
Quarterly

*Brazilian Bulletin*  
Brazilian Government Trade Bureau  
551 Fifth Av.  
New York, N.Y. 10017  
Monthly

*Bulletin of the Republic of Iraq*  
Embassy of the Republic of Iraq  
1801 P St., NW  
Washington, D.C. 20034  
Monthly

- Bureau of Federal Credit  
Unions Bulletins*  
BFCU  
Department of Health, Education and Welfare  
633 Indiana Av., NW  
Washington, D.C. 20004  
Quarterly
- Business and Economic Review*  
First National Bank of Chicago  
38 S. Dearborn St.  
Chicago, Ill. 60690  
Monthly
- Canadian Association of  
Geographers Education Newsletter*  
Morrice Hall  
McGill University  
Montreal 2, Quebec  
Canada
- Caps Central Committee for Conscientious  
Objector News Notes*  
Central Committee for Conscientious  
Objectors  
2016 Walnut St.  
Philadelphia, Pa. 19103  
Bi-monthly
- Chicago Today*  
University of Chicago  
5801 S. Ellis St.  
Chicago, Ill. 60637  
Quarterly
- Chile – Economic Notes*  
Chilean Development Corp.  
80 Pine St.  
New York, N.Y. 10005  
Semi-monthly
- Cleveland Trust Company  
Business Bulletin*  
Cleveland Trust Co.  
Euclid and E. 9th St.  
Cleveland, Ohio  
Monthly
- Clipper Cargo Horizons*  
Pan American World Airways  
Pan Am Building  
New York, N.Y. 10017  
Monthly
- Commercial Letter*  
Economics Department  
Head Office  
Canadian Imperial Bank of Commerce  
25 King St., W  
Toronto, Ont.  
Canada  
Monthly
- Communities in Action*  
Community Action Program  
Office of Economic Opportunity  
Washington, D.C. 20506  
(Public Affairs Office)
- The Conservation Volunteer*  
Minnesota Conservation Department  
658 Cedar St.  
St. Paul, Minn. 55101  
Bi-monthly
- Consumer Buying Prospects*  
Commercial Credit Co.  
330 St. Paul Place  
Baltimore, Md.  
Quarterly
- Consumer Price Index*  
Bureau of Labor Statistics  
North Central Regional Office  
219 S. Dearborn St.  
Chicago, Ill. 60603  
Quarterly
- The Consumer Price Index*  
U.S. Department of Labor  
Bureau of Labor Statistics  
441 G Street, NW  
Washington, D.C. 20212  
Monthly
- Civil Rights Newsletter*  
Colorado Civil Rights Commission  
Room 312  
State Service Building  
1525 Sherman St.  
Denver, Colo. 80203
- The Core Teacher\**  
Temple University  
Philadelphia, Pa.  
Quarterly



*Crosswords Communicque*  
Operation Crosswords Africa, Inc.  
150 Fifth Av.  
New York, N.Y. 10011

*Delaware Conservationist*  
Board of Game and Fish Commission  
Dover, Dela.  
Quarterly

*Eagle*  
Federal Reformatory for Women  
Alderson, W.Va.  
Quarterly

*Econ Notes*  
Minnesota State Council on  
Economic Education  
1169 Business Administration Building  
University of Minnesota  
Minneapolis, Minn. 55455

*Economic Education Bulletin*  
Center for Economic Education  
Montclair State College  
Upper Montclair, N.J. 07043  
Quarterly

*EDC Annual Report*  
Educational Development Center  
55 Chapel St.  
Newton, Mass. 02160

*Electronic Age*  
Radio Corporation of America  
30 Rockefeller Plaza  
New York, N.Y. 10020

*ESCP Newsletter*  
Earth Science Curriculum Project  
Box 1559  
Boulder, Colo. 80301  
Quarterly

*European Community*  
European Community Information  
Service  
900 17th St., NW  
Washington, D.C. 20007  
Monthly

*Fact Sheet*  
Federal Home Loan Bank Board  
Washington, D.C. 20552  
Semi-annually

*Farm Credit Journal*  
Farm Credit District of Spokane  
214 N. Wall St.  
Spokane, Wash.  
Semi-annually

*Finance Facts*  
National Consumer Finance Association  
1000 16th St., NW  
Washington, D.C. 20036  
Monthly

*Florida Conservation News*  
State Board of Conservation  
107 W. Gainier St.  
Tallahassee, Fla. 32304  
Monthly

*Ford Times*  
Ford Motor Co.  
American Road  
Dearborn, Mich.  
Monthly – free to Ford owners

*Free China Weekly*  
China Publishing Co.  
1270 Sixth Av.  
New York, N.Y.  
Weekly

*Front Lines*  
Agency for International  
Development Information  
4894 Department of State  
Washington, D.C. 20523  
Semi-annually

*Fund and Bank Review*  
International Monetary Fund  
19th and H Streets  
Washington, D.C. 20431  
Quarterly

*The Futurists*  
World Future Society  
P. O. Box 19285  
Twentieth St. Station  
Washington, D.C. 20036

*Ghana News*  
Embassy of Ghana  
2460 16th St., NW  
Washington, D.C. 20009  
Monthly

*Green Light*  
Denver and Rio Grande Western  
Railroad Co.  
1531 Stout St.  
Denver, Colo.  
Monthly

*Harvard University Press Newsletter*  
Harvard University Press  
79 Garden St.  
Cambridge, Mass. 02138  
Monthly

*Here/Now U.S.A.*  
Amerwalir Cult Corp.  
225 E. 47th St.  
New York, N.Y. 10017  
Monthly

*Hoosier Schoolmaster*  
Indiana Department of Public Instruction  
Room 120, State House  
Indianapolis, Ind. 46204  
Quarterly

*Human Relations News of Chicago*  
Chicago Commission on Human Relations  
211 W. Wacker Drive  
Chicago, Ill. 60606  
Bi-monthly

*India News*  
Information Service of India  
Embassy of India  
2107 Massachusetts Av., NW  
Washington, D.C. 20008  
Weekly

*Indian Education*  
Bureau of Indian Affairs  
1951 Constitution Av., NW  
Washington, D.C. 20242

*Illinois Central Magazine*  
Illinois Central Railroad  
135 E. 11th Place  
Chicago, Ill. 60605  
Monthly

*Insight*  
Scunci Research Associates, Inc.  
259 E. Erie St.  
Chicago, Ill. 60611

*International Economic Review*  
The First National Bank of Chicago  
38 S. Dearborn St.  
Chicago, Ill. 60603  
Monthly

*International Financial News Survey*  
International Monetary Fund  
19th and H St.  
Washington, D.C.  
Weekly

*The International Volunteer*  
International Secretariat for  
Volunteer Services  
1424 16th St., NW  
Washington, D.C. 20036  
Quarterly

*Japan Report*  
Japan Information Services  
Consulate General of Japan  
235 E. 42nd St.  
New York, N.Y. 10017  
Bi-monthly

*Junior High School Newsletter*  
Indiana State University  
Terre Haute, Ind.

*Keeping Up*  
Newsletter of the Clearinghouse  
for Education and Social Science  
970 Aurora  
Boulder, Colo. 80302

*Kodak Movie News*  
Eastman Kodak Co.  
343 State St.  
Rochester, N.Y. 14650  
Quarterly

*Living Museum*  
Illinois State Museum  
Springfield, Ill.  
Monthly

*Lucky Book Club News*  
Scholastic Book Services  
50 W. 44th St.  
New York, N.Y. 10036

*Mapmakers*  
Aero Service Cap  
210 E. Courtland St.  
Philadelphia, Pa. 19120  
Quarterly

*Meals for Millions*  
*Foundation Newsletter*  
Meals for Millions Foundation  
1800 Olympic Blvd.  
Santa Montica, Calif.  
Quarterly

*Michigan Council for*  
*Geographic Education Newsletter*  
Michigan Council for Geographic Education  
Box 188B  
Williamston, Mich. 48855

*Monthly Economic Letter*  
Economics Department  
First National Bank  
399 Park Av.  
New York, N.Y. 10022

*National Human Newsletter*  
P. O. Box 1266  
Denver, Colo. 80207  
Monthly

*NATO Letter*  
Distribution Planning  
Office of Media Services  
Department of State  
Washington, D.C.  
Monthly

*Nebraska on Its March*  
Division of Nebraska Resources  
Lincoln, Neb.  
Bi-monthly

*Negro Press Digest*  
New York Chapter  
American Jewish Committee  
165 E. 16th St.  
New York, N.Y. 10022  
Monthly

*News and Notes on the*  
*Social Sciences*  
101 Lindley Hall  
Indiana University  
Bloomington, Ind. 47401

*News Bulletin*  
The Russian Studies Center for  
Secondary Schools  
The Andrew Millon Library  
The Choate School  
Wallingford, Conn. 06492

*Newsclips*  
National Urban League, Inc.  
55 E. 52nd St.  
New York, N.Y. 10022  
Bi-monthly

*News From South Africa*  
South African Information Services  
655 Madison Av.  
New York, N.Y. 10017  
Weekly

*Newsletter*  
Social Sciences Educational Consortium  
Social Sciences Building  
970 Aurora  
Boulder, Colo. 80302

*News Nores*  
Foundation for International  
Cooperation  
1655 West Jackson Blvd.  
Chicago, Ill. 60612

*News of the HSUS*  
Humane Society of the United States  
1145 19th St., NW  
Washington, D.C.  
Bi-monthly

*News of the World's Children*  
U.S. Committee for the United  
Nations Children's Fund  
United Nations  
New York, N.Y. 10017  
Bi-monthly

*Newsletter*  
Center for Teaching International  
Relations  
Graduate School of International Studies  
University of Denver  
Denver, Colo. 80210

*Newsletter*  
Joint Council of Economic Education  
1212 Avenue of the Americas  
New York, N.Y. 10036

*Newsletter of the  
Twentieth Century Fund*  
41 E. 70th St.  
New York, N.Y.  
3 Yearly

*Off the Press*  
Stacey's  
2775 Hanover St.  
Palo Alto, Calif. 94304  
Monthly

*On Its Tract*  
Joseph V. Baker Associates, Inc.  
1712 Christian St.  
Philadelphia, Pa.  
Quarterly

*Open Court Newsletter*  
Open Court Publishing Co.  
1058 Eighth St.  
LaSalle, Ill. 61301  
Monthly

*Pakistan Affairs*  
Embassy of Pakistan  
Washington, D.C.  
Semi-monthly

*Palestine Refugees Today*  
U.N. Relief and Works Agency  
for Palestine Refugees  
U.N.R.W.A. Liaison Office  
United Nations  
New York, N.Y.  
Bi-monthly

*The Paperback Goes to School*  
Bureau of Independent Publishers and  
Distributors  
122 E. 42nd St.  
New York, N.Y. 10017  
Annually

*Pesticide-Wildlife Studies,  
Review of Fish and Wildlife Services  
Investigation*  
Superintendent of Documents  
Government Printing Office  
Washington, D.C.  
Annually

*Photoclips*  
National Urban League, Inc.  
55 E. 52nd St.  
New York, N.Y. 10022  
Bi-monthly

*Raeford Record*  
Florida State Prison  
P. O. Box 221  
Raeford, Fla. 32083  
Quarterly

*Research News and Notes*  
Research Program in Child Development  
Institute for Juvenile Research  
232 E. Ohio St.  
Chicago, Ill. 60611  
Quarterly

*Resources*

Resources for the Future, Inc.  
1755 Massachusetts Av., NW  
Washington, D.C. 20036

*Road Maps of Industry*

National Industrial Conference Board  
845 Third Av.  
New York, N.Y. 10022  
Semi-monthly

*Rockwell-Standard News*

Rockwell-Stanford Corp.  
Clifford at Baghy  
Detroit, Mich. 48231  
Quarterly

*Rockwell Water Journal*

Rockwell Manufacturing Co.  
400 N. Lexington Av.  
Pittsburgh, Pa.  
Bi-monthly

*Romanian Bulletin*

Embassy of Romanian Peoples' Republic  
1607 23rd St., NW  
Washington, D.C. 20008  
Monthly

*Royal Bank of Canada Monthly  
Letter*

The Royal Bank of Canada  
P. O. Box 6001  
Montreal, Quebec  
Canada  
Monthly

*School Services Newsletter*

Foreign Policy Association  
345 E. 46th St.  
New York, N.Y. 10036

*Science and Security*

Harris, Upham & Co.  
120 Broadway  
New York, N.Y. 10004  
Quarterly

*Southern Africa Bulletin*

American Committee of Africa  
211 E. 43rd St.  
Room 705  
New York, N.Y. 10025

*Southwest Pacific News Digest*

Ferrell Lines, Inc.  
1 Whitehall St.  
New York, N.Y. 10004  
Bi-monthly

*Steelways*

American Iron and Steel Institute  
150 E. 42nd St.  
New York, N.Y. 10017  
5 yearly

*Studies in Family Planning*

*Population Control*  
245 Park Av.  
New York, N.Y. 10017  
Bi-monthly

*Teaching With Transparencies*

Hammond Inc.  
515 Valley St.  
Maplewood, N.J. 07040  
Quarterly

*Union Pacific Bulletin*

Union Pacific Railroad Co.  
1416 Dodge St.  
Omaha, Neb.  
Quarterly

*Urban Review*

Center for Urban Education  
33 W. 42nd St.  
New York, N.Y. 10036  
Bi-monthly

*U.S. National Commission  
for UNESCO Newsletter*

State Department  
Washington, D.C.

*Viet Nam Report*

Information Office  
Embassy of Viet Nam  
Washington, D.C.  
Bi-monthly

*Water in the News*  
Water Resources Review  
Geological Survey  
Interior Department  
Washington, D.C.

*What's New in Co-op Information*  
Cooperative League of the U.S.A.  
59 E. Van Buren St.  
Chicago, Ill. 60605

*World Business*  
The Chase Manhattan Bank  
1 Chase Manhattan Plaza  
New York, N.Y. 10015  
Bi-monthly

*World Law Fund*  
Institute for International Order  
11 W. 42nd St.  
New York, N.Y. 10036

ERIC Clearinghouse on the  
Urban Disadvantaged  
Teachers College  
Columbia University  
New York, N.Y. 10027

ERIC Clearinghouse on Reading  
and Communication Skills  
NCTE/ERIC  
1111 Kenyon Road  
Urbana, Ill. 61801

ERIC Clearinghouse on Rural  
Education and Small Schools  
Box AP, University Park Branch  
New Mexico State University  
Las Cruces, N.M. 88001

#### 4. Booklists

##### (1) Special Subjects

*AAAS Science Booklist for Young Adults.* Hilary J. Deason. American Association for the Advancement of Science, 1515 Massachusetts Av., NW, Washington, D.C. 20005.

*Adult 100 Books: A Gateway to Better Intergroup Understanding.* American Jewish Committee, 1969.

*An Index to Young Readers' Collective Biographies.* Judith Silverman. Lists 471 collective biographies for elementary and middle school kids. Bowker, 1970.

*A Bibliography of Recreational Mathematics.* William Schaaf. Useful list for building a classroom library. National Council of Teachers of Mathematics, 1906 Association Drive, Reston, Va. 22091.

*A Place to Start.* Robert Leibert. Lists thousands of titles appropriate to school subject areas, especially social studies. Includes reading level, interest level, author and publisher. Reading Center, University of Missouri, 52nd and Holmes, Kansas City, Mo. 64110.

*Bibliotherapy.* Corinne Riggs. Annotated bibliography of sources on bibliotherapy. International Reading Association.

*Books About Negro Life for Children.* Augusta Baker. Annotated list of books arranged by subject and age level. Includes criteria for selection. New York Public Library.

*Books in American History: A Basic List for High Schools.* John E. Wiltz. Annotations of more than 300 titles suitable for high schools, arranged by historical period. Gives publisher and price. Includes paperback editions where available. Indiana University Press, Bloomington, Ind. 47401.

*Children and Books.* May Arbuthnot and Zena Sutherland. Valuable resource book in locating literature for children and young people. Scott Foresman, 1972.

*The High School Mathematics Library.* William Schaaf, 800 titles. Includes magazine titles and publishers directory. National Council of Teachers of Mathematics, 1906 Association Drive, Reston, Va. 22091.

*Historical Fiction: A Guide for Junior and Senior High Schools and Colleges.* Hannah Logasa. Also for the general reader. McKinley Press, Philadelphia, 1974. (Z5917 .H6L86 1964 in GLS, Ed.R.R.)

*Mathematics Library - Elementary and Junior High School.* Clarence Hardgrove and Herbert Miller. Annotated bibliography of mathematics books for classroom library. Includes grade level K-9. National Council of Teachers of Mathematics, 1906 Association Drive, Reston, Va. 22091.

*Negro Literature for High School Students.* Barbara Dodds National Council of Teachers of English, 1968.

*Outstanding Biographies for College Bound Students and Outstanding Fiction for College Bound Students.* Young Adult Service, Division, American Library Association.

*Reading Ladders for Human Relations.* Muriel Crosby. Annotated list of over 1,000 books for children and young people, developed around six human relations themes. American Council on Education, One DuPont Circle, NW, Washington, D.C. 20036.

*Red, White and Black: (and Brown and Yellow).* Jarold H. Laskey. Combined Paperback Exhibit. Scarborough Park, Albany Post Road, Briarcliff Manor, N.Y. 10510, 1970.

*Reference Materials for School Libraries.* Cora Paul Bomar and others. Designed as a guide in selecting and using reference materials in North Carolina Schools, grades 1-12. Publications, State Department of Public Instruction, Raleigh, N.C. 1965.

*We Build Together.* Charlemae Rollins. Selected list of black fiction, history, biography, poetry, folklore, music, science and sports. National Council of Teachers of English, 1967.

(2) Current Titles

*Booklist and Subscription Books Bulletin.* A guide to current books published twice a month, September through July, and once in August. Reviews recommended books for children, young people and adults, giving full buying and cataloging information and analytical notes. Includes annual list of notable children's books. American Library Association.

*Choice.* A monthly magazine which reviews carefully and in detail books for colleges. Especially valuable for selecting books for mature high school students. American Library Association.

*The Horn Book Magazine.* Discriminating reviews of books for children and young people, along with articles on children's literature. Carries regular section on science books and on adult books for young people. Includes annual list of outstanding books. The Horn Book, Inc., 585 Boylston St., Boston, Mass. 02116.

*Library Journal.* Published twice monthly. Valuable for reviews of adult books for high schools on all subjects. In the issue which comes out the 15th of the month, *School Library Journal* is included. R. R. Bowker.

*School Library Journal.* Monthly, September through May. Brief reviews of books recommended and not recommended for grades K-12. Articles of interest to teachers and school libraries; special lists (professional reading, free and inexpensive materials, paperbacks). R. R. Bowker.



*Wilson Library Bulletin*. Monthly, except July and August. Contains book reviews, reference books and current titles for young readers. H. W. Wilson.

(3) General

*A Basic Book Collection for High Schools*. Eileen F. Noonan and others. Approximately 1,500 titles for the high school library. Includes paperback editions, magazines and audiovisual aids. American Library Association.

*A Basic Book Collection for Junior High Schools*. Margaret Y. Spengler and others. Titles arranged by subject, annotated and indexed. Also lists magazines. American Library Association.

*Best Books for Children*. Patricia H. Allen. Lists recommended books, grouped by age level and grade, along with several subject groupings. Contains some suitable adult titles. Revised annually. R. R. Bowker.

*Book Bait*. Elinor Walker. Adult books popular with young people. American Library Association, 1969.

*Books and the Teen-Age Reader*. G. Robert Carlsen. Bantam Books, Inc., 271 Madison Av., New York, N.Y. 10016.

*Books for the Teen Age*. Annual selection of about 1,500 books, including both recent and older books. One-line annotations for books of the current year. Gives publishers but not price. Published each January. New York Public Library.

*Books for You*. Committee on the Senior High Book List. National Council of Teachers of English. Annotated list of leisure reading for high school students, 1964.

*Book Selection Aids for Children and Teachers in Elementary and Secondary School*. Milbrey L. Jones. U.S. Government Printing Office, OE-30019, 1966.

*The Children's Bookshelf*. The Child Study Association of America. Bantam Books, Inc., 271 Madison Av., New York, N.Y. 10016.

*Children's Books Too Good to Miss*. May Hill Arbuthnot, Margaret Mary Clark, Harriet Geneva Long. The Press of Case Western Reserve University. Cleveland, Ohio, 1966.

*Doors to More Mature Reading: Detailed Notes on Adult Books for Use with Young People*. Young Adult Services Division, American Library Association. Detailed annotations of nearly 150 adult books.

*Junior High School Library Catalog*. Rachel Shor and Estelle A. Fidell. 3,278 books selected for use in junior high schools. Annual supplements. H. W. Wilson.

*Let's Read Together: Books for Family Enjoyment.* National Congress of Parents and Teachers and the Children's Services Division, American Library Association. About 500 titles, grouped by reader interest and age level, 1964.

*The Paperback Goes to School.* Annual list of paperback titles considered useful for classroom and supplementary use by a joint committee of the National Education Association and the American Association of School Librarians. Bureau of Independent Publishers and Distributors. 122 E. 42nd St., New York, N.Y. 10017.

*A Parent's Guide to Children's Reading.* Nancy Larrick. Pocket Books, Inc., 1 West 39th St., New York, N.Y. 10018.

*Patterns in Reading: An Annotated Book List for Young Adults.* Jean Carolyn Roos. Readable and appealing books grouped in 100 categories such as "Science Fiction," "Mountain Climbing," etc. Excellent for building up school or public library, general reading collection. Gives publisher but not price. American Library Association, 1961.

*Standard Catalog for High School Libraries.* Dorothy Herbert West, Estelle A. Fidell and Rachel Shor. Catalog of 4,212 books selected for use in junior and senior high schools. Annual supplements. H. W. Wilson.

*Subject Index to Books for Intermediate Grades.* Mary K. Eakin. Analyzes the contents of 1,800 books and primary trade books with under 4,000 subject headings which meet today's curriculum and interest needs for grades 4-6. American Library Association, 1963.

*Your Reading, A Book List for Junior High.* Committee on the Junior High School Book List, National Council of Teachers of English. Brief descriptive annotations, grouped under subjects. National Council of Teachers of English, 1966.

(4) Publishers Directory

Addison Wesley Publishing Co.  
2725 Sand Hill Road  
Menlo Park, Calif. 94025

Allyn and Bacon, Inc.  
Rockleigh, N.J. 07647

American Book Co.  
55 Fifth Av.  
New York, N.Y. 10003

American Education Publications  
Education Center  
Columbus, Ohio 43216

American Guidance Service, Inc.  
Circle Pines, Minn. 55014

American Library Association  
50 E. Huron St.  
Chicago, Ill. 60611

Paul S. Amidon and Associates, Inc.  
1035 Plymouth Building  
Minneapolis, Minn. 55400

AMSCO School Publications  
315 Hudson St.  
New York, N.Y. 10017

Appleton-Century-Crofts  
60 E. 42nd St.  
New York, N.Y. 10017

Associated Educational Services  
Corp.  
630 Fifth Av.  
New York, N.Y. 10020

Baldrige Reading Instruction  
Materials  
14 Grigg St.  
Greenwich, Conn. 06830

Bantam Books, Inc.  
666 Fifth Av.  
New York, N.Y. 10019

Barnell Loft, Ltd.  
Dexter and Westbrook, Ltd.  
958 Church St.  
Baldwin, N.Y. 11510

Benefic Press  
10300 W. Roosevelt Road  
Westchester, Ill. 60153

Berkley Publishing Corp.  
200 Madison Av.  
New York, N.Y. 10016

Better Reading Program, Inc.  
232 E. Ohio St.  
Chicago, Ill. 60611

Book Lab, Inc.  
Department AC  
1449 37th St.  
Brooklyn, N.Y. 11218

R. R. Bowker and Co.  
1180 Avenue of the Americas  
New York, N.Y. 10036

Bowmar Publishing Corp.  
Glendale, Calif. 91201

William C. Brown Co.  
135 S. Locust St.  
Dubuque, Iowa 52001

Children's Press, Inc.  
1224 W. Van Buren St.  
Chicago, Ill. 10001

College Skills Center  
101 W. 31st St.  
New York, N.Y. 10001

Communacad  
The Communication Academy  
Box 541  
Wilton, Conn. 06897

Coronet Instructional Materials  
65 E. South Water St.  
Chicago, Ill. 60601

Curriculum Research Associates  
330 New York Av.  
Box 848  
Huntington, N.Y. 17743

Dell Publishing Co.  
750 Third Av.  
New York, N.Y. 10017

Developmental Reading Distributors  
1944 Sheridan Road  
Laramie, Wyo.

Ed-U Press  
760 Ostrom Av.  
Syracuse, N.Y. 13210

Educational Developmental Laboratory  
74 Prospect St.  
Huntington, N.Y. 11746

Educational Progress Corp.  
P.O. Box 45633  
Tulsa, Okla. 74145

Educational Record Sales  
157 Chambers St.  
New York, N.Y. 10007

Educators Publishing Service  
301 Vassar St.  
Cambridge, Mass. 02139

EMC Corp. 180 E. Sixth St. St. Paul, Minn. 55101	D. C. Heath and Co. 285 Columbus Av. Boston, Mass. 02116
Eye Gate House, Inc. 146-01 Archer Av. Jamaica, N.Y. 11435	Hertzberg New Method, Inc. Vandalia Road Jacksonville, Ill. 62650
Fearon Publishers, Inc. 2165 Park Blvd. Palo Alto, Calif. 94306	Hoffman Information Services, Inc. 2626 S. Peck Road Monrovia, Calif. 91016
Fern Tripp 2035 E. Sierra Way Dinuba, Calif. 93618	Holt, Rinehart and Winston, Inc. 383 Madison Av. New York, N.Y. 10017
Field Educational Publications, Inc. 609 Mission St. San Francisco, Calif. 94105	Houghton Mifflin Co. 110 Tremont St. Boston, Mass. 02107
Follett Publishing Co. 1010 W. Washington Blvd. Chicago, Ill. 60607	International Reading Association 800 Barksdale Road Newark, Del. 19711
Garrard Publishing Co. 1607 N. Market St. Champaign, Ill. 61820	Jamestown Publishers P. O. Box 6743 Providence, R.I. 02904
Ginn and Co. Statler Building Boston, Mass. 02117	Laidlaw Brothers Thatcher and Madison River Forest, Ill. 60305
Globe Book Co. 175 Fifth Av. New York, N.Y. 10010	Learn, Inc. 21 E. Euclid Av. Haddenfield, N.J. 08033
Grolier Educational Corp. 845 Third Av. New York, N.Y. 10022	Learning Materials, Inc. 100 E. Ohio St. Chicago, Ill. 60611
C.S. Hammond and Co. Maplewood, N.J. 07040	Learning Research Associates 1501 Broadway Av. New York, N.Y. 11106
Harcourt, Brace and Jovanovich, Inc. 757 Third Av. New York, N.Y. 15017	Leswing Communication, Inc. San Francisco, Calif.
Harr Wagner Publishing Co. Subsidiary of Field Educational Publications 609 Mission St. San Francisco, Calif. 94105	J.B. Lippincott Co. E. Washington Square Philadelphia, Pa. 19105

Lyons and Carnahan  
407 E. 25th St.  
Chicago, Ill. 60616

McGraw-Hill Book Co.  
330 W. 42nd St.  
New York, N.Y. 10036

The Macmillan Co.  
866 Third Av.  
New York, N.Y. 10022

Charles E. Merrill Books, Inc.  
1300 Alum Creek Drive  
Columbus, Ohio 43216

National Association for the Deaf  
814 Thayer Av.  
Silver Spring, Md. 20910

National Council of Teachers of English  
1111 Kenyon Road  
Urbana, Ill. 61801

New Dimensions in Education, Inc.  
131 Jericho Turnpike  
Jericho, N.Y. 11753

Noble and Noble Publishers, Inc.  
750 Third Av.  
New York, N.Y. 10017

Oxford Book Co.  
387 Park Avenue South  
New York, N.Y. 10016

Teachers College Press  
1234 Amsterdam Av.  
New York, N.Y. 10027

Perceptual Developmental  
Laboratories  
6767 Southwest Av.  
St. Louis, Mo. 63143

Pocket Books, Inc.  
1 W. 39th St.  
New York, N.Y. 10018

Polaski Co.  
Box 7466  
Philadelphia, Pa. 19101

Prentice-Hall, Inc.  
Englewood Cliffs, N.J. 07632

Pyramid Publications  
444 Madison Av.  
New York, N.Y. 10022

Random House/Singer, Inc.  
201 E. 50th St.  
New York, N.Y. 10022

Reader's Digest Services, Inc.  
Pleasantville, N.Y. 10570

The Reading Laboratory, Inc.  
55 Day St.  
South Norwalk, Conn. 06854

St. Martin's Press, Inc.  
175 Fifth Av.  
New York, N.Y. 10010

Scholastic Book Services, Inc.  
904 Sylvan Av.  
Englewood Cliffs, N.J. 07632

Science Research Associates, Inc.  
259 E. Erie St.  
Chicago, Ill. 60611

Scott, Foresman and Co.  
1900 E. Lake Av.  
Glenview, Ill. 60025

Silver Burdett Co.  
Morristown, N.J. 07960

Steck-Vaughn Co.  
P. O. Box 2028  
Austin, Tex. 78767

Warren Schloat Productions, Inc.  
150 White Plains Road  
Tarrytown, N.Y. 10591

Washington Square Press  
630 Fifth Av.  
New York, N.Y.

J. Weston Walch Publishers  
Portland, Me. 04104

Webster Division  
McGraw-Hill Book Co.  
Manchester Road  
Manchester, Mo. 63011

H. W. Wilson Co.  
950 University Av.  
Bronx, N.Y. 10452

Winston Press  
25 Groveland Terrace  
Minneapolis, Minn. 55403

Word Games  
P. O. Box 305  
Healdsburg, Calif. 95448

Xerox Education Division  
600 Madison Av.  
New York, N.Y. 10022

# 23 Evaluation of Reading Programs

Accurate and comprehensive evaluation is needed to ensure quality reading programs. A well managed reading program will have clearly defined goals and objectives, which, if attained, will demonstrate the effectiveness of the program or, if not attained, will show areas where improvement is needed.

The most important outcome of any reading program is the success of individual students in relation to the goals and objectives of the program. Therefore, the most important level of evaluation should determine the progress made by students.

In order to evaluate student progress, several strategies may be used, such as standardized and criterion referenced tests, observation and other objective data, including the number of books read or performance in specific reading tasks.

Evaluation is also needed for other aspects of the program. To enable students to work in an environment conducive to success, evaluation should include areas such as teacher effectiveness, teaching methods, facilities and instructional materials and equipment. In addition, inservice training to upgrade teacher effectiveness should be evaluated. Therefore, many stages of the reading process will require evaluation in order to ensure that student goals and objectives will be reached.

- A. **BASIC DECISION-MAKING DESIGN FOR THE SECONDARY READING PROGRAMS.** The following is a basic decision-making evaluation design for secondary reading programs. It shows the steps needed to put together an evaluation program. For example, the program to be evaluated may be a basic course for high school freshmen with goals related to improved rate of reading, study skills, vocabulary and comprehension. The decision might be to use a standardized test for each of the above areas. The evaluation decision is much broader than simply administering pre- and post-tests. The teacher might wish to determine the success level for each student based on the pre-test score. Also, other goals such as attitude toward reading may be involved. Objective measurement such as number of pages read, number of books checked out from room collection or specific class contributions could be noted to measure attitude change.

## BASIC DECISION-MAKING EVALUATION DESIGN FOR SECONDARY READING PROGRAMS

Based on your beliefs (values) in reading and teaching reading.  
Based on the environmental situation of which you are a part.

Continual planning and structuring of decisions	Alternatives (choices — limits)	Information Needs	Data Collection Procedures	Results
What do you want to teach, how, with what organizational patterns?	What are my choices and limits?	What information do I want to find out?	How and when will I collect information?	What happened? Did it work?
Should the objectives for the program be modified this semester?	List and implement objectives.	Expert and personal feedback on objectives. Performance on objectives.	Develop initial, weekly, midyear and final evaluations on objectives.	Study continuous data on accomplishment of objectives, procedures, materials, physical resources and organizational patterns.
Should the procedures to meet the program objectives be modified this semester?	List and implement procedures.	Expert feedback on procedures. Performance on procedures.	Develop initial, weekly, midyear and final evaluations on procedures	
Should the materials, and physical resources to meet the objectives be modified this semester?	List and implement materials and physical resources.	Expert and administrative feedback on materials, physical resources. Performance with all.	Develop initial, weekly, midyear and final evaluations on all.	Dependent upon results, terminate, continue, evolve or drastically modify training experiences.
Should organizational patterns to meet the objectives be modified this semester?	List and implement organizational patterns.	Expert and administrative feedback on organizational patterns. Performance in organizational patterns.	Develop initial, weekly, midyear and final evaluations on organizational patterns.	



1. **Checklist on Adequacy of a Reading Program's Statement of Objectives.** In any list of management steps, objectives must be determined before anything else. Staffing, organization and other management steps, including evaluation, occur only to fulfill the objectives of the organization. The following checklist will help determine if the objectives are adequate. Item 11 is especially important in that behaviorally stated objectives can be measured and evaluated, while statements such as "to have an appreciation of good literature" may prove difficult to evaluate.

	<i>Excellent</i>	<i>Adequate</i>	<i>Poor</i>
1. Were the objectives written in consultation with a) an evaluation specialist, b) an advisor from the state department of education, c) appropriate curriculum specialists and d) representatives of all personnel groups (administrators, nurses, teachers, librarian, etc.)?	<input type="checkbox"/>	<input type="checkbox"/>	<input type="checkbox"/>
2. Are the objectives explicitly based on established needs of the student and staff population immediately involved?	<input type="checkbox"/>	<input type="checkbox"/>	<input type="checkbox"/>
3. Is the counterpart <i>need</i> of each <i>objective</i> explained in the program rationale?	<input type="checkbox"/>	<input type="checkbox"/>	<input type="checkbox"/>
4. Are general goal areas identified for the program?	<input type="checkbox"/>	<input type="checkbox"/>	<input type="checkbox"/>
5. Are specific objectives stated for each general goal area?	<input type="checkbox"/>	<input type="checkbox"/>	<input type="checkbox"/>
6. Have the objectives included <i>all</i> important objectives, without overlooking those that are very obvious, difficult to measure or hard to describe?	<input type="checkbox"/>	<input type="checkbox"/>	<input type="checkbox"/>
7. Are the objectives stated in a logical organization which shows their implications for staffing, scheduling, equipping, preparation of staff, etc?	<input type="checkbox"/>	<input type="checkbox"/>	<input type="checkbox"/>
8. Is the language of the statement of objectives direct and simple in style (jargon-free)?	<input type="checkbox"/>	<input type="checkbox"/>	<input type="checkbox"/>
9. Is it written clearly enough and in sufficient detail so that <i>all</i> persons connected with the program can understand the objectives?	<input type="checkbox"/>	<input type="checkbox"/>	<input type="checkbox"/>
10. If needed, are special wordings prepared for specific audiences – parents, governmental officials, students, teachers, administrators and auxiliary staff?	<input type="checkbox"/>	<input type="checkbox"/>	<input type="checkbox"/>
11. Are the objectives stated in behavioral language so that program evaluation processes are easily developed?	<input type="checkbox"/>	<input type="checkbox"/>	<input type="checkbox"/>

- |   | <i>Excellent</i>         | <i>Adequate</i>          | <i>Poor</i>              |
|---|--------------------------|--------------------------|--------------------------|
| 12. Do the objectives specify the names or types of instruments to be used in gathering data for evaluation?  | <input type="checkbox"/> | <input type="checkbox"/> | <input type="checkbox"/> |
| 13. Are the statements of objectives so clearly and specifically written that each of the personnel can identify operationally the instructional and organizational steps necessary to reach the program goals? | <input type="checkbox"/> | <input type="checkbox"/> | <input type="checkbox"/> |
| 14. Is ongoing evaluation of the effectiveness of the program itself one of its objectives?   | <input type="checkbox"/> | <input type="checkbox"/> | <input type="checkbox"/> |

2. **A Checklist for Evaluating Classroom Organization for Teaching Reading.** The next management step following the selection of goals and objectives is that of creating an organization to achieve the goals and objectives. The following checklist provides items to consider when evaluating the organization that has been established to achieve the goals and objectives. It may well be that goals and objectives for an existing organization have been changed. An important task may be to change the organization so that all resources can be utilized to ensure success. The checklist emphasizes the need to think about students and their needs, to formulate correct goals and to utilize successful instructional procedures.

#### **STUDENT CHARACTERISTICS**

- Is a reasonable opportunity of success ensured?
- Is stigmatization avoided?
- Is a strong self-concept encouraged?
- Is peer interaction facilitated?
- Is pupil-teacher interaction facilitated?
- Is student cooperation encouraged?
- Are students' group-roles clearly defined?
- Is student initiative encouraged?
- Are student experience backgrounds and opinions utilized?
- Is the learning situation learner-directed?
- Can differing rates of learning be provided for?
- Can the varied interests of students be met?

#### **INSTRUCTIONAL GOALS**

- Are a variety of word recognition methods practiced?
- Is flexibility of rate encouraged?
- Is accuracy of word perception facilitated?
- Do the skills of comprehension, whether they are literal, inferential, critical or appreciative, receive adequate practice?
- Are the various study skills practiced?
- Is a reasonable balance maintained between oral and silent reading?
- Is content-area reading facilitated?
- Is there opportunity for students to apply what they have read?
- Are students' reading interests broadened?
- Are students' reading attitudes and habits improved?

## IMPLEMENTATION

- Is expertise maximally utilized?
- Are teacher preferences and interests considered?
- Can adequate samples of students' reading behavior be obtained?
- Can diagnosis of growth and of specific skill needs be obtained?
- Is scheduling simplified?
- Can a variety of materials be employed?
- Are the requisite resources within the school's means?

- B. **EVALUATIVE TECHNIQUES FOR READING PROGRAMS.** Listed below are evaluative techniques for the total reading program. Questions are asked about various areas which will provide aid as an evaluation program is being devised. These techniques are related to those tasks which help bring about a good atmosphere for a reading program, in contrast to techniques which are used directly with students. However, students do gain because proper materials are used and because the staff is properly prepared, which indicates the importance of evaluation for all aspects of the reading program.

### PROGRAM GOALS:

*Objectives.* Are the objectives of the program specific and clearly defined?

*Operating Procedures.* Are the operating procedures clear to all personnel involved, and is there evidence that they are working?

*Evaluation.* Is ongoing evaluation which is based on several devices and several points of view built into the program?

*Staff.* Are the supervisors, teachers and aides professionally prepared for their jobs? Is adequate inservice education available on a continuing basis?

*Public Relations.* Are parents, taxpayers and the general community well informed about the program's merits and needs?

*Skill Building.* Does the program provide sequential basic skill instruction with directed applications to a variety of reading situations?

*Diagnosis and Individualization.* Is corrective and remedial assistance provided and based on the prescription of ongoing diagnosis so that the specific reading needs of all students are met?

*Materials.* Does the program have an adequate supply of facilities, equipment and materials appropriate to the situation and goals?

*Innovativeness.* Does the program experiment with innovative materials, methods and organizational patterns according to a plan that anticipates, guides and evaluates the effort?

*Facilities.* Are the physical facilities of the program appropriate for the accommodation of personnel and materials in a manner leading to effective goal completion?

*Comprehensiveness.* Does the program provide the students and teachers with a variety of activities, services and materials?

- C. **PRACTICES RELATED TO READING AND READING INSTRUCTION IN CONTENT AREAS.** One area of the secondary program that is of vital importance but difficult to accomplish is that of involving teachers not specifically assigned in the reading program. Social studies, science and mathematics teachers could benefit from inservice training provided by one of the reading teachers in the school. The following two checklists will help these teachers as they evaluate their practices in helping students to read material in their subject areas.

Teacher's Name: \_\_\_\_\_ Subject Taught: \_\_\_\_\_

The 20 practices listed below are often recommended in effectively teaching the special reading skills in the various content areas. Indicate the extent to which this practice applies to your classes.

	<i>Almost Always</i>	<i>Sometimes</i>	<i>Seldom or Never</i>
1. Text material used is suited in difficulty to the reading levels of students.	<input type="checkbox"/>	<input type="checkbox"/>	<input type="checkbox"/>
2. Students are encouraged through assignments to read widely in related materials.	<input type="checkbox"/>	<input type="checkbox"/>	<input type="checkbox"/>
3. At the beginning of the year adequate time is taken to introduce the format of the text and to discuss how it may be read effectively.	<input type="checkbox"/>	<input type="checkbox"/>	<input type="checkbox"/>
4. The teacher is aware of the special vocabulary and concepts introduced in the various units.	<input type="checkbox"/>	<input type="checkbox"/>	<input type="checkbox"/>
5. Adequate attention is given to vocabulary and concepts introduced in the various units.	<input type="checkbox"/>	<input type="checkbox"/>	<input type="checkbox"/>
6. Provisions are made for checking on extent to which important vocabulary and concepts are learned, and reteaching is done where needed.	<input type="checkbox"/>	<input type="checkbox"/>	<input type="checkbox"/>
7. The teacher knows the special study skills involved in the subject and teaches them.	<input type="checkbox"/>	<input type="checkbox"/>	<input type="checkbox"/>
8. The course content is broader in scope than a single textbook.	<input type="checkbox"/>	<input type="checkbox"/>	<input type="checkbox"/>
9. The assignments are made clearly and concisely.	<input type="checkbox"/>	<input type="checkbox"/>	<input type="checkbox"/>
10. Students are taught to use appropriate reference materials.	<input type="checkbox"/>	<input type="checkbox"/>	<input type="checkbox"/>

- |   | <i>Almost<br/>Always</i> | <i>Sometimes</i>         | <i>Seldom or<br/>Never</i> |
|---|--------------------------|--------------------------|----------------------------|
| 11. Adequate reference materials are available.   | <input type="checkbox"/> | <input type="checkbox"/> | <input type="checkbox"/>   |
| 12. Plenty of related informational books and other materials are available for students who read <i>below grade</i> level.                         | <input type="checkbox"/> | <input type="checkbox"/> | <input type="checkbox"/>   |
| 13. Plenty of related informational books and other materials are available for students who read <i>above grade</i> level.                         | <input type="checkbox"/> | <input type="checkbox"/> | <input type="checkbox"/>   |
| 14. The teacher takes advantage of opportunities that may arise to encourage students to read recreational as well as informational reading matter. | <input type="checkbox"/> | <input type="checkbox"/> | <input type="checkbox"/>   |
| 15. The teacher helps the poor reader to develop adequate reading skills.   | <input type="checkbox"/> | <input type="checkbox"/> | <input type="checkbox"/>   |
| 16. Readings from various textbooks are provided for those who cannot read the regular text.  | <input type="checkbox"/> | <input type="checkbox"/> | <input type="checkbox"/>   |
| 17. Students are grouped within the classroom for differentiated instruction.   | <input type="checkbox"/> | <input type="checkbox"/> | <input type="checkbox"/>   |
| 18. The teacher knows the reading level of the textbook(s) being used.  | <input type="checkbox"/> | <input type="checkbox"/> | <input type="checkbox"/>   |
| 19. The teacher knows the reading ability of the students from standardized tests, other evaluative materials and/or cumulative records.            | <input type="checkbox"/> | <input type="checkbox"/> | <input type="checkbox"/>   |
| 20. The teacher illustrates the dominant writing pattern of a given content area.   | <input type="checkbox"/> | <input type="checkbox"/> | <input type="checkbox"/>   |

**D. CHECKLIST OF TEACHER PRACTICES RELATING TO READING INSTRUCTION IN HIGH SCHOOL CONTENT AREAS**

- |  | <i>Very well</i>         | <i>Adequately</i>        | <i>Not at all</i>        |
|--|--------------------------|--------------------------|--------------------------|
| 1. Do you repeatedly discuss with your classes effective study techniques for the reading goals of each course? Have you periodically reviewed these and practiced until students study well by habit? | <input type="checkbox"/> | <input type="checkbox"/> | <input type="checkbox"/> |
| 2. Do you teach specific vocabulary words and concepts special to your field or probably new to students and thoroughly check, from time to time, student understanding of these words and concepts?   | <input type="checkbox"/> | <input type="checkbox"/> | <input type="checkbox"/> |

- |   | <i>Almost<br/>Always</i> | <i>Adequately</i>        | <i>Seldom or<br/>Never</i> |
|---|--------------------------|--------------------------|----------------------------|
| 3. Do you weave into each course more reading material than the central text so that students have to use critical thinking to evaluate various presentations on the same topic?  | <input type="checkbox"/> | <input type="checkbox"/> | <input type="checkbox"/>   |
| 4. Do you consult, as the need arises, with all the following:<br>cumulative file<br>parents<br>librarian<br>counselor<br>nurse<br>other teachers<br>record of standardized test scores<br>reading, curriculum, or language arts coordinator? | <input type="checkbox"/> | <input type="checkbox"/> | <input type="checkbox"/>   |
| 5. Have you arranged to see individual students who need personal (either advanced or corrective) attention?  | <input type="checkbox"/> | <input type="checkbox"/> | <input type="checkbox"/>   |
| 6. Do you define and analyze the specific subskills that limit the student's effectiveness in studying each reading assignment?   | <input type="checkbox"/> | <input type="checkbox"/> | <input type="checkbox"/>   |
| 7. Have you given clear assignments so that students know what you expect them to be able to do as a result of their exposure to the material read? (Have you worded your objectives for the students in performance language?)               | <input type="checkbox"/> | <input type="checkbox"/> | <input type="checkbox"/>   |
| 8. Do you encourage students to do library reading that parallels their coursework?   | <input type="checkbox"/> | <input type="checkbox"/> | <input type="checkbox"/>   |
| 9. Have you suggested to your classes (or to individuals) books below their grade level as well as at and above grade level?  | <input type="checkbox"/> | <input type="checkbox"/> | <input type="checkbox"/>   |

E. **TEACHER SELF-INVENTORY OF TESTING.** The following is a good self-inventory to consider when working with test results. The ethical behavior of those entrusted with test results should be of the highest quality. All testing should be utilized to help students, not to harm them in any manner.

1. Do I make note of students whose behavior during the test strongly suggests that their test results will be invalid?
2. Do I arrange for students who were absent to "make-up" the test?
3. Do I rescore a sample of the tests to make sure that the scoring was accurately accomplished?

4. Do I check the accuracy of the addition of the part scores and of the pupil age data?
5. Am I careful to be explicit when I record pupil test data so that other teachers and personnel will benefit from a knowledge of my testing (e.g., rank the grade equivalents from high to low, show percentile ranks of all pupils in the classroom, etc.)?
6. Do I help pupils analyze the results on their second papers in terms of correct and incorrect responses?
7. Do I avoid at all times making a statement about any pupil's IQ to parents, other teachers, etc.?

- F. **EVALUATION OF MATERIALS.** Good materials are necessary for a good reading program. Educators are constantly faced with decisions regarding the selection and utilization of materials. The following provides some structure for evaluating materials which might be utilized in a secondary reading program.

Name of Goal and Guiding Question

*Social Class Experience.* Is the student using materials appropriate to his experiential background?

*Development.* Does the material provide for the emotional and social development of the student?

*Format.* Do the physical aspects of the material present an inviting and attractive format which adds ease of reading?

*Interest.* Does the material provide for appeal to a variety of interests and develop deep and permanent interests in reading?

*Validity.* Have the reading materials proven worthy for usage through testing and previous application of them?

*Illustrations.* Do the illustrations in the material provide both informational data and aesthetic appeal?

*Balance.* Does the material present a balance between fiction and true-to-life happenings?

- G. **CHECKLIST FOR EVALUATING THE INSERVICE PROGRAM.** The following checklist is for evaluating inservice reading programs. An inservice program which would have 'yes' checked for each question would be rather powerful. So much is dependent on inservice education that evaluation should be very carefully done. Ineffective inservice education is not only a waste of time but could actually lower morale of teachers and cause less rather than more productive performance.

1. Was the evaluation considered in the light of changing teaching procedures and pupil performance?
2. Was the purpose for the program to equalize the opportunities for professional growth for all participants?

3. Were topics selected for study the most urgent needs of the group and were they of concern to all of the participants?
4. Were classroom teachers' instructional problems in reading discussed and suggestions for improvement of instruction in the classroom offered?
5. As a planned part of the program, were discussions and ideas which evolved from the inservice work transferred to the classroom setting?
6. Was the leadership role shared by teachers, principals, superintendents, instructional supervisors and reading consultants?
7. Was provision made for securing an open atmosphere of communication of problems and concerns between administrators and the teachers?
8. Was the program coordinated at all levels?
9. Were the overall goals and outcomes defined clearly from the beginning in order that the program be (a) understood by the participants and (b) appropriate for the work to be accomplished?
10. Was provision made for modifications of the overall plan as unforeseen problems and needs evolved?
11. Were teachers and administrators given help in selecting the materials made available for use in the program?
12. Was provision made to help teachers translate the results of research studies into classroom practice?
13. Were originality and creativity in teaching reading encouraged?
14. Were experienced teachers encouraged to make needed changes in their programs?
15. Were new teachers aided in becoming adjusted to the classroom?
16. Were consultants from outside the system who worked in the program well informed about the background of the local situation in order to aid them in making worthwhile contributions?
17. Did pupil performance in and enjoyment of reading improve as a result of the inservice program?
18. Was the level of instruction in the classroom improved as a result of the inservice program?

A good evaluation plan will provide objective data which will indicate success or failure of all aspects of the secondary reading program. Evaluation properly done will reassure all concerned that the program is successful or will point out those areas needing improvement. It is continuous in that a constant flow of information is provided to see that movement is being made toward the attainment of goals and objectives. Thus evaluation is a positive management tool which helps keep the secondary reading program moving in the right direction so that students will have success in reading.



## Model Programs

A reading program for a particular school or school system should be tailored to fit local needs. Consequently, it is difficult to identify a "model" program already existing in a school or school system that is sufficiently comprehensive to provide for all contingencies which may exist in the schools whose faculty members turn to this publication for guidance and assistance.

However, there are numerous effective secondary school (middle, junior high and senior high school) reading programs in Indiana. A few of these programs are described in the following pages. Please keep in mind that the programs described were selected because (1) they have been effective in their local context, and (2) they were known to the members of the committee responsible for preparing this document. Readers may know of other equally effective programs which were overlooked and would have merited inclusion if the committee had been familiar with them. The reader is encouraged to examine the programs with an open and constructively critical mind, to borrow freely whatever insights he can use and to modify creatively the good ideas which do not quite fit his particular situation. Although each program is different, each one of the programs has found the necessity of the leadership of a reading teacher or reading specialist.

### Evansville-Vanderburgh School Corporation, Evansville, Indiana

Recognizing that the need for instruction in reading skills is not limited to the elementary school years but continues throughout the secondary school years, the Evansville secondary school reading curriculum provides *developmental* programs for students whose progress in reading skill acquisition has been satisfactory, *corrective* instruction in subject matter courses for students needing extra help in reading skills and *remedial* classes for students who are seriously handicapped in reading skills areas. The reading curriculum is viewed as an integral component of the secondary curriculum, in contrast to a "special" program.

The Evansville *Guide to Reading Instruction, Grades 9-12* consists of five chapters: The Reading Laboratory, Developmental Reading, Corrective Reading, Remedial Reading and Phase Elective English-Reading Courses. A brief overview of each chapter follows:

*The Reading Laboratory.* This chapter identifies professional literature about reading that is useful to teachers, describes a model reading laboratory, outlines the duties of the reading coordinator, delineates guidelines for the placement of students within the total reading program and contains a glossary of reading terms. The English curriculum, of which reading is an important segment, has four divisions related to the student's ability and needs. Assignment to the appropriate division is made on the basis of student placement guidelines.

*Developmental Reading.* The objectives include vocabulary skills in the areas of word structure, use of context clues, dictionary use and comprehension skills in the areas of locating main ideas, distinguishing the relative importance of specific details, interpreting meanings (literal, implied and inferred), distinguishing fact from opinion, studying efficiently, developing and extending individual reading interests and adjusting reading rate to the type and difficulty of the material being read. The developmental reading program centers around the reading laboratory, making extensive use of tachistoscopic and controlled reader devices, and emphasizes building comprehension skills and vocabulary.

*Corrective Reading.* This chapter contains objectives for corrective reading and specific suggestions for teachers in each of five subject areas: English, social studies, science, mathematics and practical arts. The objectives are broadly stated, including assessing the needs and abilities of each class, developing background or readiness for the upcoming instructional unit, developing vocabulary that is specific to the subject, providing practice in skills required for the subject and encouraging wide reading of books, periodicals and reference materials.

*Remedial Reading.* The remedial reading chapter contains sections on objectives, diagnostic information and procedures, program organization and materials and evaluation materials and procedures. The objectives are divided into three categories: (1) major objectives, (2) strategies or activities for accomplishing the major objectives and (3) a statement of how students will be evaluated in relation to the major objectives. Five groups of major objectives are set forth: word attack, vocabulary, comprehension, recreational reading and oral and silent reading.

As word attack objectives, the student will (1) recognize at sight words that are common to all areas, (2) learn to use contextual clues in pronouncing and understanding words, (3) use structural clues to determine unknown words and (4) use phonics clues to decode unknown words. In vocabulary, the student will develop an understanding of (1) words common to many areas, (2) words peculiar to a certain area and (3) practical words used in everyday language, reading and communication.

Objectives for comprehension skills are learning to (1) locate the main idea of a paragraph or an article, (2) distinguish between important and less important details as they relate to the main idea, (3) follow written directions and (4) question materials for fact and opinion.

To accomplish oral and silent reading objectives, the student will read orally to the tutor or teacher and read silently on an independent basis materials at this individual reading level. For recreational reading the student will learn how to locate materials on his interest level and develop an interest in reading magazines, newspapers and books. Activities to accomplish these objectives include work with appropriate materials, small group instruction, instruction on a one-to-one basis, reading books of interest at the students' achieved educational level and use of a variety of reading materials at a variety of reading levels.

*Phase Elective English – Reading Courses.* This chapter contains a brief description of phase elective English and a course description of the phase elective reading program offered to Evansville high school students. The two courses involved are "Improving Reading Techniques" and "Basic Reading Skills."

#### **Fort Wayne Community Schools, Fort Wayne, Indiana**

The secondary developmental reading program of the Fort Wayne Community Schools is based upon a conviction that specific instruction in reading should continue beyond the elementary grades through the junior and senior high schools into college. The need for the mastery of reading skills continues to increase in our society. The world of books is expanding rapidly. Just to keep up with events and the main currents of thought, "a person needs to read rapidly, efficiently and critically."

Also underlying the Fort Wayne program is a conviction that all boys and girls, with the exception of those with severe disabilities, can be helped to become better readers. Because of this, the program is made available to virtually all students in the school system. To capitalize upon skills that are gained in the concentrated aspects of the program, 7th grade students in the junior high schools and

10th grade students in the high schools are enrolled in reading classes.

A basic purpose of the program is to "bring students to an effective performance level commensurate with their capacity." Teachers in subject areas contribute greatly to student reading success by teaching vocabulary that is peculiar to the subject, encouraging critical and multi-source reading, and by giving students individual assistance in reading-study skills needed for the particular subject.

There are four general objectives of the program. They are (1) to increase the enjoyment of reading, (2) to increase interest in current events literature, (3) to improve reading efficiency and work-study skills for greater accomplishment in subject areas and (4) to improve the student's ability to make intelligent use of what he reads (to react critically to the reading experience).

Seven specific objectives are identified for the grade 7 program. The objectives include skimming techniques, greater efficiency in reading speed and comprehension, ability to study independently, outlining skills, word recognition and vocabulary independence, use of reference and source materials and improvement of oral reading and listening. The 7th grade program continues for two semesters and groups students according to tracking procedures.

The 10th grade program has seven objectives: developing functional reading skills, promotion of spelling, word recognition and vocabulary growth, development of associational skills by evaluating and drawing conclusions, improvement of reading flexibility, improvement of work-study skills in the subject areas and stimulation of recreational reading. All sophomores, except certain severely handicapped students and some students enrolled in music (who, consequently, take reading in their 11th . . .), take an intensive nine-week developmental reading course. Ordinarily, students are scheduled into reading during their study period and are homogeneously grouped for reading classes. During the 10th grade course, extensive use is made of tachistoscopic devices and controlled readers in order to build reading speed.

In addition, an elective reading course is offered in grade 12. The specific objectives of the 10th grade course are also the objectives of this elective course. All 12th grade students are eligible for the course; college-bound students, in particular, are urged to enroll.

#### Gary Community School Corporation, Gary, Indiana

During the 1973-74 school year, the Gary reading teachers in the secondary schools developed an extensive list of specific performance objectives for teaching reading skills. Record-keeping forms were also developed for use with the performance objectives in assessing placement and achievement levels of students and in recording progress of skill mastery. Detailed performance skills were identified in the following areas: vocabulary development, comprehension development, study skills development and listening development. Specific components of each of these developmental areas were identified in detail.

Vocabulary development was analyzed in terms of phonetic and other word attack skills, techniques for eliciting word meanings, comprehension power skills and rates of comprehension. The comprehension power skills are further analyzed as *literal meaning skills*: details, main ideas, sequence, directions and relationships; *organizational skills*: setting purposes, functional sequence, outlining, author's organization, locating information, summarizing, classifying and synthesizing; *inferential (interpretive) skills*: details, main ideas, sequence, comparisons-contrasts, cause-effect/effect-cause, outcome anticipation, conclusions, generalizations and connotations; *critical reaction skills*: fact/opinion, prerequisites, evaluation guidelines, patterns of clear thinking, errors in reasoning, propaganda, interdisciplinary relationships and literary forms and *creative*

*reaction skills*: emotional response reactions to author's use of language and imagery, fusion and application.

Study skills development is analyzed under eight major subskill headings. Following directions, locating information in textbooks and using references are the first three major subskills. The fourth subskill, organizing information, is defined by three subheadings: taking notes, outlining and summarizing. The other four subskills under study skills development are library skills, reading rates, use of the SQ3R basic study plan and taking tests.

Listening development is analyzed into four subskills: tuning oneself, constructing questions as a guide to listening, listening skills and reviewing and relating ideas. The listening skills are further subdivided into 16 categories which generally parallel reading comprehension techniques.

### **Gary Community Schools, Gary, Indiana**

The Gary *Middle School Reading Curriculum – Grades 6-8* is described in a 30-page bulletin which is divided into sections on "Language Arts in the Middle School," including the following topics: organization and structure, philosophy and objectives, testing procedures, types of reading instruction, basic principles of reading instruction, course of instruction for developmental reading (which consists of scope and sequence outlines and suggested materials for vocabulary, comprehension, study skills and listening development), and "Course of Instruction for Remedial Reading." Two appendices also appear in the bulletin entitled (a) Directed Developmental Reading Lesson and (b) SQ3R.

It is proposed in the guide that the middle school language arts curriculum be reorganized, with the traditional English courses becoming four or five mini-courses in language arts. Two major purposes will be served by this reorganization: (1) instruction in reading by a qualified reading teacher will become an integral part of the language arts program, and (2) mini-course goals and objectives will be clearer to students and teachers than were the objectives for the former courses because they will not deal with such comprehensive segments of the total curriculum. Instruction is to be directed toward meeting specific performance objectives.

Seven directions are given for implementing the reorganized curriculum. The program is to be referred to as language arts rather than English. Grouping classification labels are to be dropped, although "classes may be grouped to accommodate needs of students who are not making average progress." A suggested general plan of organization proposes that the curriculum for each year be divided into language mechanics (10 weeks), oral and written communication (9 weeks), literature (9 weeks) and developmental reading (10 weeks). Language arts teachers, remedial reading teachers and developmental reading teachers will be scheduled for common planning periods. Remedial classes will be limited to no more than 15 students. During the first two days of the school year, all students will be tested with the Gates MacGinitie Test D (grouping adjustments may be made on the basis of this test). If a school staff prefers ability grouping in grade 7 or 8, the following level designations are recommended: Phase I – Remedial Level (reading below 4.0), Phase II – Below Average Achievement (reading at 4.0 to 6.0, but other factors are to be considered), Phase III – Average and Above, and Phase IV – Accelerated.

The main objectives of the *Middle School Reading Curriculum* are to provide a developmental reading program for maintaining, enriching and implementing skills and a remedial reading program to help students who have the potential to learn to read but who are not reading up to capacity. Reading is looked upon as a complex of skills that involves mental, communicative, pleasurable and multi-skill processes which facilitate oral and written self-expression.

Testing procedures are delineated in terms of placement and diagnostic testing. Tests which are to be used with all students are described. Also, appropriate additional tests available for teacher use are listed.

Under "Types of Reading Instruction" the curriculum guide briefly describes the developmental and remedial reading instruction. In the developmental reading statement, a developmental reading program is identified as a continuous process of maintaining previously acquired skills and of providing additional help to students who are not progressing satisfactorily. Such a program is based upon the concept of readiness and the sequential treatment of reading skills. Also in this section, reading level ranges for Phase II and Phase III placement are displayed in a table.

The remedial reading program is defined as being for children who have not mastered basic word attack skills and who are not reading above the 4.0 level. Students for this program are to be selected from the regular school population and not from special programs such as those for the educable mentally handicapped and children from non-English speaking heritages.

"Basic Principles of Reading Instruction" consists of two divisions: determining reading placement and directed developmental reading lessons (a sample lesson plan is included as Appendix A of the curriculum guide). Under determining reading placement, independent reading level, instructional reading level, frustration level and capacity level are defined in operational terms to assist teachers in lesson planning.

Ten specific objectives are identified for the developmental reading course. They include building interest and enjoyment in reading, maintaining strength in phonetic and structural word-attack skills, enlarging vocabulary skills and knowledge and improving comprehension ability. Also included are developing better study skills, developing skill in following oral and printed directions and improving reading in the content skills. Additionally, the objectives encompass knowing the various rates of reading and how to adapt them when needed, increasing ability in oral reading and improving use of the library and knowledge of library skills.

The course of study is detailed in greater specificity by the scope and sequence outlines for vocabulary development, comprehension development, study skills development and listening development.

For the remedial reading course of instruction, two objectives are stated: (1) to teach the basic initial word recognition skills in order to develop vocabulary and (2) to develop comprehension skills. The guide states, "remedial instruction is nothing more than practical developmental lessons which are applied on an individual or small group basis." Seven considerations which the reading teacher should keep in mind are also given. They are: (1) determine the strengths and weaknesses of each student by thorough diagnosis, (2) select materials to meet individual needs on the basis of test results, (3) instructional procedures must be highly organized, (4) provisions should be planned for continuous practice and reinforcement of skills being developed, (5) a continuous program of evaluation for each student is necessary and urgent in order to assess the value of the teaching procedures being employed, (6) each student should experience some feelings of success during the course of each lesson and (7) all teachers who work with remedial readers must show an attitude that they are sincerely interested in the reader's welfare. It is intended that, just as soon as students in the remedial program attain word attack skills and a basic sight vocabulary, they are to be reassigned to Phase II developmental reading classes.

#### **Wilson Middle School Reading Laboratory, Muncie, Indiana**

The Wilson Middle School reading program has four major objectives: (1) to provide systematic

reading instruction to students in the basic areas, (2) to offer remedial instruction to capable students who are one, two or more years below normal grade level in reading achievement, (3) to improve the reading skill of slow learners and (4) to provide enrichment skill instruction for capable students. The basic areas covered by the first objective are word recognition, word meaning, comprehension skills, speed reading, study skills, increasing interest in and attitude toward reading and reading for appreciation. In respect to improving the reading skill of slow learners, two guidelines are invoked: begin where they are and proceed systematically from word recognition techniques to primary comprehension skills.

A first step in meeting the objectives is the testing of all 7th grade students. Those scoring at the 3.0 level or lower are retested with an individual reading test.

The instructional program has four components. Units on word analysis, vocabulary development and comprehension skills are taught. Study skills, both general and those specific to content areas, are presented in the classrooms under the joint direction of the classroom teacher and the reading teacher. Small group instruction is from two to four hours each week for students who are reading below 3rd grade level. Special interest lessons and/or projects are planned and taught in cooperation with the 7th grade team-teaching program.

# Acknowledgments

It is with a great sense of pride and accomplishment that the outstanding contribution of the following individuals who developed this curriculum guide is recognized:

John Childrey  
Purdue University

J. David Cooper  
Ball State University

Jessie J. DuBois  
Division of Reading Effectiveness  
Department of Public Instruction

Richard Earle  
Indiana University

Barbara Pashos, Director  
Division of Reading Effectiveness  
Department of Public Instruction

Peggy Ransom  
Ball State University

Betty Ryder  
Division of Reading Effectiveness  
Department of Public Instruction

Stuart Silvers  
Butler University

Ray Slaby  
Associate Superintendent  
Department of Public Instruction

Cyrus Smith Jr.  
Indiana University

Tim Wells  
Division of Reading Effectiveness  
Department of Public Instruction

Phillip Whiteman  
Division of Reading Effectiveness  
Department of Public Instruction